

Holoplanktonic Mollusca (Gastropoda: Pterotracheoidea, Janthinoidea, Thecosomata and Gymnosomata) from the Pliocene of Pangasinan (Luzon, Philippines)

Arie W. Janssen

Janssen, A.W. Holoplanktonic Mollusca (Gastropoda: Pterotracheoidea, Janthinoidea, Thecosomata and Gymnosomata) from the Pliocene of Pangasinan (Luzon, Philippines). *Scripta Geologica*, 135: 29-177, 25 pls., 8 figs., 27 tables. Leiden, November 2007.

Arie W. Janssen, Nationaal Natuurhistorisch Museum Naturalis, P.O. Box 9517, 2300 RA Leiden, The Netherlands; currently: 12, Triq tal'Hamrija, Xewkija XWK 9033, Gozo, Malta (ariewjanssen@waldonet.net.mt.).

Keywords – Mollusca, Pliocene, Philippines, taxonomy, new species.

Fifteen samples taken from interbedded sandstone, siltstone and claystone of Pliocene age, underlying the Bolinao Limestone, at the localities Anda, Roxas and Tiep (Pangasinan, Luzon, Philippines), were analysed for holoplanktonic gastropods; they have yielded 50 species (16 Heteropoda, one Janthinidae, and 33 Pteropoda, the latter consisting of 30 Euthecosomata, two Pseudothecosomata and one Gymnosomata). Faunal diversity between the localities sampled is restricted and explained by differences in sample size and/or preservation. The time interval represented by all samples taken together is postulated to have been brief. Fifteen new taxa (= 30% of the total number of encountered holoplanktonic molluscan species) are erected; *Atlanta lingayanensis* sp. nov., *A. richteri* sp. nov., *A. seapyi* sp. nov., *Heliconoides sondaari* sp. nov., *Striolimacina andaensis* sp. nov., *Hyalocylis marginata* sp. nov., *Cavolinia baniensis* sp. nov., *C. perparvula* sp. nov., *C. shibatai* sp. nov., *Diacavolinia pristina* sp. nov., *Diacria italica* Grecchi, 1982 f. *fissicostata* f. nov., *D. microstriata* sp. nov., *D. paeninsula* sp. nov., *D. philippinensis* sp. nov. and *Sphaerocina convolvula* sp. nov.

Calibration with vertical ranges of holoplanktonic molluscan species as now known enables an age assignment for the Pangasinan assemblages of Pliocene (Piacenzian). A number of species, in particular Atlantidae (Heteropoda), were so far known only from Quaternary or extant assemblages. Comparisons with published data for Japan allow the conclusion that the Philippine assemblages are coeval with the Takanahe Member (Miyazaki Group) in Miyazaki Prefecture (southwest Japan), a unit which incidentally has yielded far fewer species. The absence of bathypelagic holoplanktonics, as well as littoral benthic species indicate an epi- to upper mesopelagic setting, with depth ranges extending to a maximal depth of c. 200 to 300 m.

Contents

Introduction	29
Geological setting	31
Localities and material	32
Methods	34
Systematic palaeontology	35
Age assignment and palaeoenvironment	107
Acknowledgements	114
References	115

Introduction

During the 1999 Naturalis-USC expedition, Dr Willem Renema (Nationaal Natuurhistorisch Museum; NNM) collected two samples from a locality near the village of

Anda, on Cabarruyan Island (Pangasinan province, Luzon, Philippines), mainly for analysis of foraminiferal faunas. When both samples turned out also to contain numerous holoplanktonic molluscs, the present author was invited to study them.

The results were spectacular. In spite of the rather fragmentary condition of, in particular, the coarser fractions of the sieving residues, an unusually high number of holoplanktonic molluscan species were concentrated from these two samples. This material contained an unprecedented number of heteropod species in the fossil record. The species composition allowed a preliminary age assignment of the samples, and some interesting data on biostratigraphical and systematic aspects were gained. An internal report (Janssen, 2000a) listed 27 and 31 species of heteropods and pteropods, respectively.

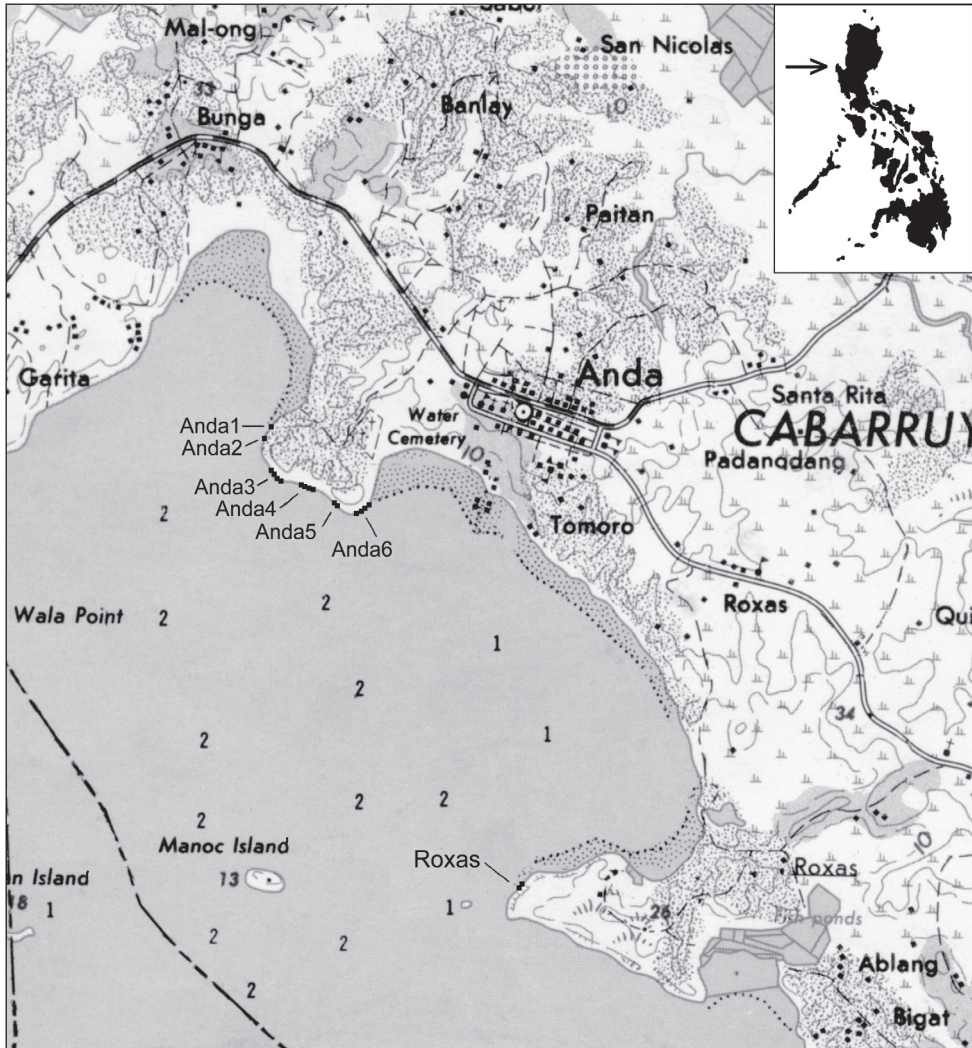

Fig. 1. Location of the samples Anda1 to Anda6, and Roxas. Fragment of the topographical map of the Philippines 1 : 25,000, map-sheet 6975-I, Bolinao.

An additional sample, taken a year later by Dr John de Vos (NNM) from approximately the same locality, gave a similar outcome.

In view of the fact that the first results were promising and the accompanying benthic, rather deep water molluscan fauna looked interesting, a further collecting trip with the main purpose of recovering the highly fragile holoplanktonic molluscs was staged in April/May 2001. The results are presented in this paper.

The few Janthinidae found in the Pangasinan material, although neustonic and not truly holoplanktonic, are also treated in this paper. Ultimately, the complete Pangasinan collection studied for the present paper consisted of over 600 holoplanktonic molluscan samples (RGM registration numbers).

Geological setting

All localities sampled are fairly close to each other, in the province of Pangasinan (Figs. 1, 2), partly on the mainland of Luzon (Tiep) and partly on Cabarruyan Island, situated in the Lingayen Gulf (Anda and Roxas). Sedimentary rocks of this area are described in Table 1 after Ocampo (1983).

All samples studied originated from the lowermost unit. The contact with the overlying Bolinao Limestone at Anda is completely covered by dense vegetation; huge fallen blocks of this rock are seen on the beach in front of the cliff.

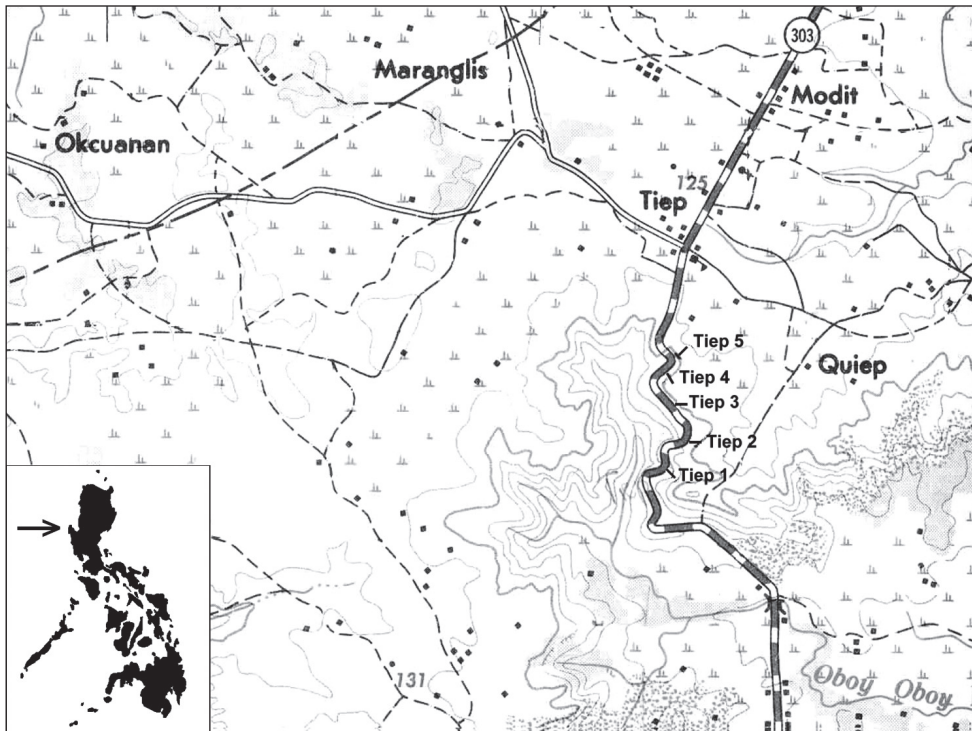

Fig. 2. Location of the samples Tiep1 to Tiep5. Fragment of the topographical map of the Philippines 1 : 25.000, map-sheet 6975-II Alaminos.

Table 1. Lithostratigraphy of the studied area (after Ocampo, 1983).

Name	Age	Thickness
Limestone Conglomerate	Middle Pleistocene	not indicated
Zaragoza Mudstone	Early Pleistocene	60 m
Bolinao Limestone	not indicated	not indicated
Interbedded sandstone, siltstone and claystone	Pliocene	not indicated

Both at Tiep (thickness of section approximately 80 m) and Roxas, strata outcropping show interbedding of harder and softer sedimentary rocks. At Anda, where only a short section is visible, no stratification could be observed, the sedimentary rock being homogeneous, marly and lacking harder intercalations (Fig. 3).

Samples AndaClif1 and AndaClif3, collected by W. Renema, were originally labelled to differ 6 m in vertical height, but this could not be verified locally. Therefore, the relative position of all Anda samples remains unknown, but it is quite probable that they do not differ significantly in age.

Localities and material

Anda (Figs. 1-3) – Localities in Anda peninsula are all situated along a low coastal cliff (Fig. 3), in which a greyish- to yellowish-brown, marly sedimentary rock is exposed over a height of a few metres only, the lowermost part being submerged at high tides. Resting on top of these marls are coralline limestones of the Bolinao Formation, but the boundary between marlstone and limestone is nowhere exposed due to very dense tropical vegetation. The lower part of the cliff is cleaned by tides and storm wave action to approximately 2-3 m above low tide level, and most larger molluscan specimens were collected by screening the exposed surfaces. In places, the lowermost intertidal part of the marl reveals a dense burrow network of a live population of isopods.

In addition to the two samples collected by W. Renema in 1999, and an additional one taken the following year by J. de Vos, material was collected by the present author at six localities in 2001, along the coast of the small peninsula. These sample localities



Fig. 3. Locality Anda6, Cabarruyan Island, Luzon, Pangasinan, Philippines.



Fig. 4. Locality Tiep 2, Pangasinan, Philippines. Fossils were collected from the temporary drainage pit dug along the roadside.

are so close to each other that the same co-ordinates are used for all of them, as a GPS device was not available at the time. Their relative positions can be seen in Figure 1. Locality data are summarised in Table 2.

It is impossible to indicate the precise locality of samples AndaClif1, AndaClif3 and AndaDeVos in relation to samples Anda1 to 6, as given in Figure 1. Washed residues >125 μm of these samples were available and, in addition, they included a number of larger benthic molluscs (predominantly gastropods), visually collected from the surface of the outcrops.

At each of the Anda 1 to 6 localities, the author spent at least two days of visual collecting in 2001. Washing of the matrix at the sites was not possible. Practically all specimens with a size over approximately 2 mm were found by breaking the rock. Small pieces of marlstone with one or more fossils were carefully packed in paper, benthic species separate from holoplanktonics. These small parcels were then allowed to dry for several days. Furthermore, from each locality a rock sample of *c.* 3-5 kg was concentrated during the collecting work, focussing on fossil-rich lumachelles.

Roxas (Fig. 1) – During a short visit by boat to this locality, situated only some 2 km southeast of the Anda localities, some higher marlstone/claystone cliffs were inspected that appeared to be mainly non-fossiliferous. A thin lense was discovered just above sea level at one place only, containing many small-sized fossils. A sample of some 3 kg was collected and yielded an interesting assemblage, the benthic molluscs of which point to a somewhat lesser water depth than the Anda samples (F.P. Wesselingh, pers. comm.). Locality data in Table 2.

Tiep (Figs. 2, 4) – Along the east side of the road from Bani to Bolinao, just south of the village of Tiep, a section of alternating marlstones and claystones is exposed. Estimated height is approximately 80 m, the dip of the strata is *c.* 15° S. Most of the rock is barely or not fossiliferous macroscopically. Five samples (from bottom to top, Tiep 1 to 5) were collected by W. Renema from south to north. Co-ordinates, as given in Table 2, were measured from the topographical map of the Philippines. Just one of these (Tiep 2; Fig. 4), a locality where a small road-side drainage pit was dug, was found to yield a more interesting mollusc assemblage. Together with W. Renema, the author spent

Table 2. Locality data.

Sample	co-ordinates		map sheet	leg.	date
AndaClif1	16°17.413'N	119°56.197'E	6975-I Bolinao	W. Renema	23.11.1999
AndaClif3	16°17.413'N	119°56.197'E	6975-I Bolinao	W. Renema	23.11.1999
AndaDeVos	16°17.413'N	119°56.197'E	6975-I Bolinao	J. de Vos	04.2000
Anda1-6	16°17.413'N	119°56.197'E	6975-I Bolinao	A.W. Janssen	28.04-09.2001
Roxas	16°16.192'N	119°56.882'E	6975-I Bolinao	A.W. Janssen	06.05.2001
Tiep1	16°13'48.6"N	119°51'32.9"E	6975-II Alaminos	W. Renema	28.04.2001
Tiep2	16°13'54.3"N	119°51'36.2"E	6975-II Alaminos	W. Renema & A.W. Janssen	28.04.2001
Tiep3	16°14'0"N	119°51'33.7"E	6975-II Alaminos	W. Renema	28.04.2001
Tiep4	16°14'3.2"N	119°51'36.2"E	6975-II Alaminos	W. Renema	28.04.2001
Tiep5	16°13'54.3"N	119°51'36.2"E	6975-II Alaminos	W. Renema	28.04.2001

several hours there breaking matrix pieces, which yielded especially a relatively high number of well-preserved cavoliniids. From all other samples just the residue of a small sediment sample was analysed. Locality data in Table 2.

Methods

Sample processing – Mr. Charles Barnard (RGM) washed the sediment samples. Fossil samples from all localities, totalling 16.5 kg, were sent to the authors' current address in Malta. During the courier transport, however, and in spite of careful packing, many specimens were damaged. It was seen during final preparation that some shrinking of the marl occurs by drying, with the result that in dry specimens some space is present between shell and matrix, causing damage of the specimens at the slightest touch.

Preparing the hundreds of specimens on pieces of matrix and sorting the residues took a year and a half (finished October 2002). The benthic material was transferred to RGM; the relatively deep-water faunas predominantly consisted of small specimens, but in a wide and very interesting variety.

Sieving residues $>250 \mu\text{m}$ were analysed in their entirety; of the finer fractions a smaller portion was analysed qualitatively. The molluscan material in the coarser fractions of these samples was very crushed, and as usual the thin-walled holoplanktonic molluscs were affected more severely than the benthic species, which were, on average, considerably more solid. Many specimens show signs of compaction, such as deformation of and cracks in the shell, making them extremely fragile. The finer fractions of most samples comprise predominantly planktic and benthic Foraminifera, and commonly high numbers of faecal pellets. Also contained in the residues, apart from Mollusca and Foraminifera, are other vertebrate and invertebrate fossils, such as annelids, anthozoans, echinoderms, cirripedes, decapods, ostracods, bryozoans and fish remains.

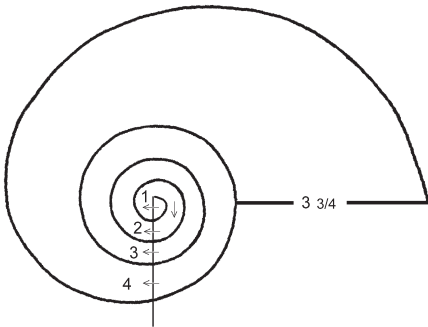

Fig. 5. Counting gastropod whorls. In this example a shell with $3\frac{3}{4}$ whorls is shown, with the fourth whorl expanding more rapidly than whorls 1-3 (see text for explanation).

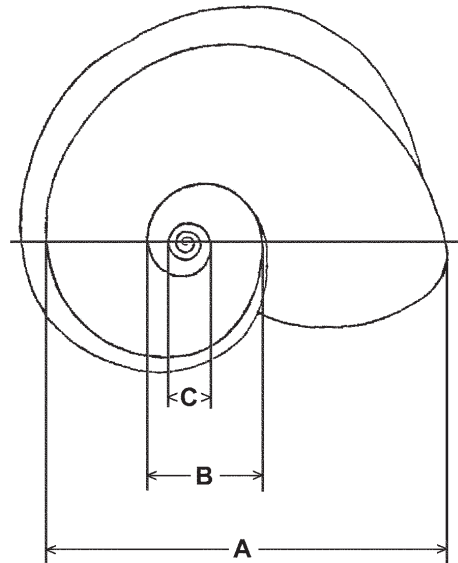

Fig. 6. Whorl formula = A : B : C (after Tokioka, 1955).

Counting the number of whorls – To count exactly the number of whorls in heteropods and limacinids the present author used the method already explained for other gastropods (Janssen & de Vogel, 1965; Gittenberger & Janssen, 1998). A straight line is drawn to separate the semi-circular nucleus (protoconch-1) from the younger part of the shell. An arrow placed at a 90° angle on this line, following the course of the whorl, reaches the end of the first whorl where it is parallel to its starting position. From that point all whorls are counted towards the margin of the shell, estimating the ultimate whorl with an accuracy of a quarter whorl. This method is illustrated in Figure 5. It should be noted that other authors (Ehrmann, 1933; Richter & Seapy, 1999) applied a slightly different measuring method, resulting in whorl numbers being a quarter higher.

Abbreviations –

A	long diameter of atlantid shell (see Fig. 6).
H	shell height.
W	shell width.
MNHN	Muséum national d'Histoire naturelle (Paris, France).
NNM	Nationaal Natuurhistorisch Museum Naturalis (Leiden, The Netherlands).
RGM	Nationaal Natuurhistorisch Museum Naturalis, Palaeontology Department collection (Leiden, The Netherlands), formerly Rijksmuseum van Geologie en Mineralogie.
RMNH	Nationaal Natuurhistorisch Museum Naturalis, Malacology Department collection (Leiden, The Netherlands), formerly Rijksmuseum van Natuurlijke Historie.
SMF	Senckenberg Museum (Frankfurt am Main, Germany).

All measurements are in mm, scale bars of SEM-images are in mm or μm . Numbers of specimens available in the lists of material examined are given in parentheses, following the RGM registration number. Symbols used in the lists of synonyms are those of Richter (1948, p. 54):

*	first valid introduction of a taxon;
.	responsibility for the identification is accepted by the present author;
(no symbol)	responsibility for the identification is not accepted by the present author, but there is no reason for doubt;
?	in the opinion of the present author there is reason to doubt the identification;
v	the original material of this reference was studied by the present author;
()	(date between brackets) the year of publication is uncertain (or the paper has not been published officially, e.g., a thesis).

Systematic palaeontology

Note – Many of the species discussed below are also known from extant assemblages. References to Recent holoplanktonic molluscs referred to in the multiple (semi-) popular handbooks on regional faunas are usually omitted. Usually, synonyms given in van der Spoel (1967, 1976b) are not repeated here.

Phylum Mollusca Linné, 1758
Class Gastropoda Cuvier, 1797
Superorder Caenogastropoda Cox, 1960
Order Sorbeoconcha Ponder & Lindberg, 1997
Suborder Hypsogastropoda Ponder & Lindberg, 1995
Infraorder Littorinimorpha Golikov & Starobogatov, 1975
Superfamily Pterotracheoidea Rafinesque, 1814
[= Heteropoda Lamarck, 1812 (partim); Carinarioida de Blainville, 1818]
Family Atlantidae Rang, 1829

Remarks – The Atlantidae is a group of holoplanktonic gastropods, which all demonstrate a strong adaptation to pelagic life, in the form of a lenticular, laterally flattened, aragonitic shell, the surface of which is further enlarged by the presence of a wide, and very thin and fragile, double-walled keel. The apex is on the right side of the shell, the umbilicus on the left. For the living animal the enlargement of the shell's surface serves 'to increase stabilization during swimming and sinking' (Richter & Seapy, 1999, p. 621). This phenomenon results in the occurrence of superficially very similar adult shells in separate species, whereas the larval shells may be utterly different.

Recent Atlantidae, in the present concept, comprise three genera, two of which, *Oxygyrus* Benson, 1835, and *Protatlanta* Tesch, 1908, are considered monospecific. In *Protatlanta*, however, a few additional fossil species have been described. Both genera are characterised by partially uncalcified (conchiolin) shell portions. Additional fossil genera considered to belong in the Atlantidae are *Bellerophina* d'Orbigny, 1843 (Cretaceous), *Eoatlanta* Cossmann, 1888 (Paleocene-Eocene) and *Mioatlanta* di Geronimo, 1974 (Miocene). Only few *Atlanta* species are known from the fossil record, the oldest one being *A. arenularia* Gougerot & Braillon (1965, p. 302, pl. 7, fig. 9a-c), from the Bartonian of the Paris Basin, which differs considerably from typical *Atlanta* by its cornucopia shape.

Atlanta includes a large number of Recent species. Lalli & Gilmer (1989, p. 52) listed 14 species, but Richter & Seapy (1999, p. 631) recognised 21 extant species, provisionally subdivided into seven 'species groups' (and one species unassigned). A further Recent species was described since; *Atlanta selvagenis* de Vera & Seapy, 2006.

Following Tesch (1908, p. 12), the taxonomic status of such species groups within the genus *Atlanta* has been discussed repeatedly. Van der Spoel (1972, p. 554) recognised several pairs of sympatric 'sibling species' and proposed to interpret them as formae. The same author (van der Spoel, 1976b, p. 140) again expressed uncertainty over the taxonomic classification of species of *Atlanta* and, rather desperately, concluded that 'a complete new nomenclature for the genus, when not in conflict with the rules, should probably be the best solution.' Meticulous research on the distinction of species has been done by Dr Gotthard Richter (SMF) resulting in a series of papers (Richter, 1972, 1973, 1974, 1986, 1987, 1990, 1993; Richter & Seapy, 1999).

Many authors (e.g., Thiriot-Quiévreux, 1973, p. 240; Richter, 1974, p. 60; Seapy, 1990, p. 107) admit that identification of *Atlanta* species is difficult and including soft-part features (eyes, radula, operculum) or application of transmitted light to observe inner shell structures (Richter, 1987, p. 178) are very helpful in distinguishing species with similar shells. However, such methods are unavailable for fossil material. This makes identifying fossil species of *Atlanta* quite difficult and even well-preserved specimens

occasionally can only be related to existing taxa with a query (e.g., *Atlanta* sp. in Janssen, 2004, p. 108; *Atlanta* cf. *echinogyra*, this paper). Advantageous in this study of fossil atlantids, however, is the fact that all specimens are preserved as opaque aragonitic shells as a result of recrystallisation, which facilitates assessing protoconch shape and ornament with a normal 25 or 50 x binocular magnification, they are thus much easier studied than in the usually very transparent and shiny Recent specimens. Still, here, too, study of the larval shell shape and micro-ornamentation by SEM is highly desirable or even indispensable.

An objective and helpful measurement for the identification of some atlantids is the whorl formula, as developed by Tokioka (1955). Although the effectiveness of this formula was denied by Richter (1987, p. 177), it does quantify the position of the larval shell within the adult shell (explained in Fig. 6). It is easily obtained from drawings made with a camera lucida, expressed in the relation of the whorl diameters as A : B : C. Together with the absolute shell diameter this gives a good method for comparison between the various species or, at least, species groups. Obviously, this formula changes with the size of the shell (or with compaction of fossil shells!) and therefore averages of these values are not useful.

The Pliocene age of the present material made it most likely that at least part of the fossil Atlantidae specimens represent still extant species. This indeed proved to be the case; nine out of 13 species could, with some certainty, be identified as species still occurring in the Recent fauna, one is only known from the fossil record and three are new.

Apart from the existing literature, samples of 17 species of Recent *Atlanta* species were available for this study, all identified by G. Richter (SMF). The author is very grateful to Dr Ronald Janssen (SMF) for the long-term loan of this very helpful comparison collection. Furthermore, a large number of Recent atlantid samples was available, predominantly from the so-called CANCAP-expeditions, housed in the RMNH collection. This material was identified by Mr J. van der Linden of RMNH in the 1990s (see van der Linden, 2003).

Identification of the specimens started with a study of the protoconchs by which ontogenetic changes of the shell could be related to more adult specimens. In this way the various taxa could be separated morphologically, after which a comparison with Recent material could be made. Finally, Professor Roger R. Seapy (California State University, Fullerton, U.S.A) was kind enough to give his opinion on identifications.

Below, synonyms for species in this family are mainly restricted to references of the original description (indicated with *) and a number of more recent authors, representing current species concepts in this group. References to papers in which descriptions and/or illustrations are insufficient to recognise the species with some degree of certainty without seeing the original material are omitted. Extensive synonymy was given for most taxa by van der Spoel (1976b).

In the Pangasinan material studied here, many, even predominantly, juvenile specimens are available. Larger, adult specimens in most cases were broken or their protoconchs are missing. From most sampled localities damaged *Atlanta* specimens are available, most of them lacking their initial whorls. Such specimens cannot be identified with any degree of certainty and are included in the collection as '*Atlanta* sp.' from the following samples: Anda1, RGM 517 495 (11); Anda2, RGM 517 496 (many), Anda3,

RGM 517 497 (8), Anda4, RGM 517 498 (many), Anda5, RGM 517499 (1); Anda6, RGM 517 500 (2, 5 fragments); AndaClif1, RGM 429 277 (1, 7 fragments); AndaClif3, RGM 429 311 (10 fragments), AndaDeVos, RGM 517 501 (13), Roxas, RGM 517 502 (7 fragments); Tiep1, RGM 517 503 (5 fragments) and Tiep2, RGM 517 504 (1, 4 fragments).

Genus *Atlanta* Lesueur, 1817

Type species – *Atlanta peroni* Lesueur, 1817 (Recent).

Atlanta cf. *echinogyra* Richter, 1972

Pl. 9, fig. 1.

- ?* 1972 *Atlanta echinogyra* Richter n. sp., p. 90, figs. 5, 7.
 ? 1974 *Atlanta echinogyra* Richter: Richter, p. 62, fig. 8c, pl. 1, fig. 5.
 ? 1976b *Atlanta echinogyra* Richter: van der Spoel, p. 150, fig. 150.
 ? 1987 *Atlanta echinogyra* Richter: Richter, p. 182, pl. 1, figs. 3, 4, pl. 2, fig. 14, pl. 4, figs. 31, 32, pl. 5, fig. 36.
 ? 1990 *Atlanta echinogyra* Richter: Seapy, p. 120, figs. 3C, D, 5E, 6F, 8E-H.

Description – *Atlanta* species with a conical protoconch of $3\frac{1}{4}$ rather convex whorls, visible in a frontal view of the adult shell. The fourth whorl (first teleoconch whorl) increases rapidly in width and bears a flange-like keel. The early whorls are covered with a distinct and relatively coarse ornament consisting of four spirals. This ornament is also visible on the base of the shell, where it is present in the umbilicus, on the last part of the protoconch.

Measurements – For six sufficiently well-preserved specimens the long diameter, the whorl formula and the number of whorls were measured (Table 3).

Material examined – AndaDeVos, RGM 517 422 (3); Anda6, RGM 517 423 (4); AndaDeVos, RGM 539 760 (1; Pl. 9, fig. 1).

Discussion – The few available specimens differ from compared Recent *Atlanta echinogyra* by their considerably coarser ornamentation of the early whorls. The fact that these spirals are also present on the base of the shell (which is not the case in Recent specimens of that species; compare Richter, 1987, fig. 14) is reminiscent of *A. inflata* Souleyet, 1852a,

Table 3. Long diameter (A), whorl formula and number of whorls for six specimens of *Atlanta* cf. *echinogyra* Richter, 1972.

Specimen	locality	A (mm)	A : B : C	number of whorls
1	AndaDeVos	1.70	1 : 0.25 : 0.14	4
2	AndaDeVos	1.62	1 : 0.25 : 0.15	4
3	AndaDeVos	1.28	1 : 0.28 : 0.15	3 $\frac{3}{4}$
4	Anda6	1.20	1 : 0.31 : 0.18	4
5	Anda6	1.14	1 : 0.30 : 0.16	3 $\frac{3}{4}$
6	Anda6	0.82	1 : 0.38 : 0.23	3 $\frac{1}{2}$

or even more of *A. helicinoides* Souleyet, 1852a. In both these species, however, the protoconch has one whorl more (Seapy, 1990, p. 120) and the shape is clearly more depressed.

***Atlanta fusca* Souleyet, 1852a**

Pl. 9, figs. 2, 3; Pl. 10, fig. 1.

- * 1852a *Atlanta fusca* Souleyet nobis, p. 389, pl. 21, figs. 15-29.
- . 1966 *Atlanta fusca* Souleyet: Frontier, p. 133, figs. 24, 25.
- . 1968 *Atlanta fusca* Souleyet: Richter, p. 13, figs. 9, 10.
- . 1973 *Atlanta fusca* Souleyet: Thiriot-Quéievreux, pp. 240, 252, figs. 1H, 6B.
- . 1974 *Atlanta fusca* Souleyet: Richter, p. 71, pl. 1, fig. 1.
- . 1976b *Atlanta fusca* Souleyet: van der Spoel, p. 145, fig. 141a-f (with extensive synonymy).
- . 1990 *Atlanta fusca* Souleyet: Seapy, p. 123, figs. 6G, 10A-D.
- . 1999 *Atlanta fusca* Souleyet: Richter & Seapy, p. 634, figs. 1A, 6E.
- . 2001 *Atlanta fusca* Souleyet: Seapy & Skoglund, p. 35.
- v. 2003 *Atlanta fusca* Souleyet: van der Linden, p. 131, fig. 5.

Description – Juveniles of this species are easily recognised by their shape and ornament. The protoconch is rather high conical and has $3\frac{1}{2}$ – $3\frac{3}{4}$ whorls, slowly increasing in diameter. On the first whorl, in front of the nucleus, an ornament is seen of some nine or ten irregular spirals (Pl. 9, fig. 2c, d; Pl. 10, fig. 1b). Two stronger spirals from the second whorl on delimit a subsutural zone and the base of the shell. On these spirals the whorl profile is slightly angular (Pl. 9, fig. 3). The whole surface of the protoconch is furthermore covered with numerous finer spirals in an irregular zigzag shape, also on the base and within the umbilicus. The boundary with the teleoconch is made distinct by the sudden disappearance of these spirals. From that point on the whorl diameter increases rapidly, by which the shape of the shell becomes lenticular. Somewhat more than one teleoconch whorl is present in the largest specimens. The periphery of the body whorl is angular and bears a distinct flange-like keel. The protoconch is visible in an apertural view.

Measurements – Thirteen sufficiently well-preserved specimens from samples Anda 1 and 2 were measured, see Table 4.

Material examined – Anda1, RGM 517 424 (12); Anda2, RGM 517 425 (10), RGM 539 761 (1; Pl. 9, fig. 2), RGM 539 762 (1; Pl. 10, fig. 1), RGM 539 763 (1; Pl. 9, fig. 3); Anda3, RGM 517 426 (5); Anda4, RGM 517 427 (13); Anda6, RGM 517 428 (18); AndaClif1, RGM 429 268 (4); Roxas, RGM 517 429 (1); Tiep2, RGM 517 430 (2); Tiep3, RGM 517 431 (3); Tiep4, RGM 517 432 (4); Tiep5, RGM 517 433 (5).

Discussion – *Atlanta fusca* belongs together with *A. turriculata* d'Orbigny, 1836, to the *A. fusca* species group (Richter & Seapy, 1999, table 4). Both species are easily recognised by their high conical protoconch, which in *A. turriculata* is even considerably more slender than in *A. fusca* and clearly carinated. Form and ornament of the Pangasinan specimens agree completely with the illustration in Thiriot-Quéievreux (1973, fig. 6B), as well as with compared Recent specimens. *Atlanta fusca* has an almost worldwide tropical and subtropical distribution pattern (van der Spoel, 1976b, fig. 230).

Table 4. Long diameter (A), whorl formula and number of whorls for 13 specimens of *Atlanta fusca* Souleyet, 1852b, from localities Anda 1 and 2.

Specimen	locality	A in mm	A : B : C	number of whorls
1	Anda1	1.62	1 : 0.28 : 0.15	4 ½
2	Anda1	1.46	1 : 0.24 : 0.14	-
4	Anda1	1.42	1 : 0.25 : 0.17	4 ¼
5	Anda2	1.40	1 : 0.28 : 0.15	4 ¼
6	Anda2	1.30	1 : 0.27 : 0.16	4 ¼
7	Anda1	0.98	1 : 0.33 : 0.19	4
8	Anda1	0.90	1 : 0.30 : 0.19	3 ½
9	Anda1	0.85	1 : 0.31 : 0.24	3 ½
10	Anda2	0.80	1 : 0.35 : 0.22	3 ¾
11	Anda2	0.78	1 : 0.36 : 0.22	3 ¾
12	Anda1	0.74	1 : 0.34 : 0.20	3 ½
13	Anda2	0.66	1 : 0.33 : 0.18	3 ¾

***Atlanta lesueuri* Souleyet, 1852a**

Pl. 10, figs. 2, 3.

- * 1852a *Atlanta lesueurii* Souleyet mihi, p. 380, pl. 20. figs. 1-8
- . 1955 *Atlanta lesueuri* Souleyet: Tokioka, p. 231, fig. 3.
- . 1966 *Atlanta lesueuri* Souleyet: Frontier, p. 132, figs. 9, 10.
- . 1968 *Atlanta lesueurii* Souleyet: Richter, p. 10, figs. 5, 6a.
- . 1973 *Atlanta lesueuri* Souleyet: Thiriot-Quévieux, p. 239, fig. 1D.
- . 1974 *Atlanta lesueuri* Souleyet: Richter, p. 62, pl. 2, fig. 9.
- . 1976b *Atlanta lesueuri* Souleyet: van der Spoel, p. 143, fig. 138a (partim, includes *A. oligogyra*; with extensive synonymy).
- . 1986 *Atlanta lesueuri* Souleyet: Richter, p. 21, fig. 1, pl. 1, figs. 1, 3.
- . 1990 *Atlanta lesueuri* Souleyet: Seapy, p. 118, figs. 5B, 6A, 7A-D.
- . 1999 *Atlanta lesueuri* Souleyet: Richter & Seapy, p. 636, figs. 1C, 6C.
- . 2001 *Atlanta lesueuri* Souleyet: Seapy & Skoglund, p. 35.
- . 2003 *Atlanta lesueurii* Souleyet: van der Linden, p. 130.
- . 2003 *Atlanta lesueuri* Souleyet: Seapy *et al.*, p. 530, fig. 11.

Description – See Richter (1986) and Seapy (1990). Main features for the recognition of this species are the protoconch composed of just 2¼-3 convex whorls, separated by an incised suture and the absence of any ornament. The first teleoconch whorl expands rapidly and bears a well-developed flange-like keel. In the largest specimens the final three quarters of the teleoconch separates from the penultimate whorl.

Material examined – Anda1, RGM 517 434 (1); Anda2, RGM517.435 (2), RGM 539 845 (1; Pl. 10, fig. 3; 5 juveniles); Anda3, RGM 517 436 (25); Anda4, RGM 517 438 (7); Anda6, RGM 517 439 (1); AndaClif3, RGM 429 305 (1); AndaDeVos, RGM 517 440 (1); Roxas, RGM 539 764 (1; Pl. 10, fig. 2); Tiep3, RGM 517 441 (2 juveniles); Tiep4, RGM 517 442 (1).

Measurements –The long diameter, the whorl formula and the number of whorls were measured (see Table 5) for eleven specimens from several locations.

Table 5. Long diameter (A), whorl formula and number of whorls for 11 specimens of *Atlanta lesueuri* Souleyet, 1852b

Specimen	locality	A (mm)	A : B : C	number of whorls
1	Anda1	2.72	1 : 0.27 : 0.08	-
2	Anda2	2.46	1 : 0.21 : 0.08	3 ¾
3	Anda1	2.36	1 : 0.27 : 0.10	-
4	Anda4	1.78	1 : 0.22 : 0.11	3 ¾
5	Anda2	1.62	1 : 0.20 : 0.10	-
6	AndaClif3	1.34	1 : 0.25 : 0.13	3 ½
7	Anda4	1.16	1 : 0.26 : 0.15	3 ½
8	Anda2	1.50	1 : 0.24 : 0.13	3 ½
9	Roxas	1.00	1 : 0.28 : 0.14	3 ½
10	Anda4	1.00	1 : 0.32 : 0.15	3 ½
11	Anda2	0.94	1 : 0.27 : 0.16	3 ¼

Discussion – This species resembles closely *Atlanta oligogyra*, in which, however, the first whorls are separated by a superficial suture and the shell remains much smaller. *Atlanta lesueuri* has a circumglobal tropical/subtropical distribution (van der Spoel, 1976b, map fig. 227). Fossil specimens have not been recorded hitherto.

Atlanta lingayanensis sp. nov.

Pl. 10, fig. 4; Pl. 11, fig. 1.

Holotype – RGM 539 846 (Pl. 10, fig. 4).

Type locality – AndaClif3, Cabarruyan Island (Pangasinan, Philippines), coastal cliff section at co-ordinates N 16° 17.413' E 119° 56.197', map-sheet 6975-I, Bolinao (Fig. 1).

Stratum typicum – Interbedded marlstone, sandstone and claystone below Bolinao Limestone Formation, stratigraphically 6 m above sample AndaClif1; Pliocene.

Derivatio nominis – Named after the Lingayan Gulf, in which Cabarruyan Island is situated, Pangasinan, Philippines.

Paratypes – Anda1, RGM 517 437 (1), RGM 517 445 (2); Anda2, RGM 517 443 (3); Anda3, RGM 517 444 (2); Anda4, RGM 517 446 (5); Anda6, RGM 517 447 (1); AndaClif3, RGM 429 304 (9), RGM 539 765 (1; Pl. 11, fig. 1); AndaDeVos, RGM 517 448 (1); Roxas, RGM 517 449 (3); Tiep2, RGM 517 450 (2).

Diagnosis – *Atlanta* species with 3½ protoconch whorls, the upper part of which is smooth or has 1-3 very fine spirals. Sides and base of protoconch with spiral lirae. Teleconch whorl only slightly widening.

Description – The largest specimen (holotype) has a shell width of 1.24 mm and 4¾ whorls, 3½ of which form the protoconch. In very juvenile specimens the shell form is

about as high as wide. The whorls attach high onto the foregoing whorl, resulting in a shell with a regular and low conical spira. All whorls increase very gradually in diameter and the last whorl (teleoconch) expands only slightly. A flange-like keel typical for Atlantidae is present on the body whorl of the largest adult specimens.

Ornament of the protoconch consists of a spiral situated exactly at the place where the suture with the next whorl will be (and then invisible) and sometimes a somewhat weaker spiral delimiting the base of the shell. In between these are 4 or 5 finer spirals. The base of the protoconch whorls in some specimens is covered with an even finer spiral ornament, but in others it is almost smooth. The space between the upper spiral and the upper suture is relatively convex, and in most shells almost smooth; in some specimens one to three very thin lirae are seen on the second and the third protoconch whorl. The boundary with the teleoconch is indicated by disappearance of the ornament, but the spiral around the base of the protoconch increases in strength and develops to the keel. In none of the specimens is there a space between the body whorl and the penultimate whorl.

Measurements – The holotype and five paratypes are sufficiently adult to be measured (Table 6).

Discussion – Specimens of *Atlanta plana* may resemble the present species, but they have a different shape of the larval shell (compare Pl. 11, fig. 1 and Pl. 12, fig. 5). This species also demonstrates some resemblance with *Atlanta helicinoides*, especially in the shape of the protoconch. However, the spiral ornament is much weaker and the teleoconch whorl is considerably narrower than in *A. helicinoides* of the same size. The same is true for *A. inflata*. Also, in the species *A. plana* Richter, 1972, or *A. echinogyra* Richter, 1972, the whorls increase much more rapidly in width.

Atlanta lingayanensis does not seem to be closely related to any of the Recent species in this genus and might be a primitive form, in which the teleoconch whorls do not yet expand laterally so much as in other species. The presence, however, of a typically atlantid flange-like keel undoubtedly refers this species to the genus *Atlanta*.

Table 6. Long diameter (A), whorl formula and number of whorls for the holotype and five paratypes of *Atlanta lingayanensis* sp. nov.

Specimen	locality	A (mm)	A : B : C	number of whorls
1 holotype	AndaClif3	1.24	1 : 0.42 : 0.26	4 $\frac{3}{4}$
2	AndaClif1	1.16	1 : 0.45 : 0.25	4 $\frac{1}{2}$
3	Anda1	1.12	1 : 0.44 : 0.25	4 $\frac{1}{4}$
4	Anda1	0.94	1 : 0.49 : 0.29	4 $\frac{1}{4}$
5	AndaDeVos	0.82	1 : 0.49 : 0.26	4
6	Roxas	0.74	1 : 0.51 : 0.26	3 $\frac{3}{4}$

Atlanta oligogyra Tesch, 1906

Pl. 11, figs. 2, 3.

- * 1906 *Atlanta oligogyra* Tesch n. sp., p. 54, pl. 8, figs. 14-18.
- . 1974 *Atlanta oligogyra* Tesch: Richter, p. 62, pl. 2, fig. 10.
- . 1976b *Atlanta lesueuri* Souleyet: van der Spoel, p. 143 (partim, non Souleyet).
- . 1986 *Atlanta oligogyra* Tesch: Richter, p. 23. fig. 2, pl. 1, figs. 2, 4.
- . 1990 *Atlanta oligogyra* Tesch: Seapy, p. 118, fig. 7E-H.
- . 1999 *Atlanta oligogyra* Tesch: Richter & Seapy, p. 636, fig. 6D.
- . 2003 *Atlanta oligogyra* Tesch: van der Linden, p. 130.

Description – See Seapy (1990). The protoconch of this species is low conical and the first two whorls are separated by a very superficial suture, becoming deeper on later whorls. The complete protoconch has no more than $2\frac{1}{4}$ - $2\frac{3}{4}$ whorls and it is the third whorl that widens rapidly. The larval shell is devoid of any ornamentation.

Measurements – Long diameter (A), whorl formula and number of whorls were measured for seven specimens from the locality Anda1 (see Table 7). Richter (1974, p. 62) mentioned a diameter of 2.8 mm for his largest specimens, which, however, had only $3\frac{1}{2}$ whorls. This number of whorls is present in the fossil specimens at a diameter less than half the value mentioned by Richter. Considering the rapid increase of the A-value this may mean a difference of no more than $\frac{1}{4}$ or $\frac{1}{2}$ whorl.

Material examined – Anda1, RGM 517 451 (6), RGM 539 847 (1; Pl. 11, fig. 2); Anda2, RGM 517 452 (8); Tiep3, RGM 517 453 (2), Tiep5, RGM 517 454 (2), RGM 539 848 (1; Pl. 11, fig. 3).

Discussion – Characteristics used to distinguish Recent specimens of this species from the closely related *Atlanta lesueuri* are predominantly the anatomy of the eyes, the radula and the coloration of the shell, which are of little practical value for fossils. Still, the SEM images given by Seapy (1990, fig. 7G-H) show a distinctly different development of the early protoconch whorls, that could be recognised in the fossils as well. A difference in the shape of the keel, mentioned for Recent specimens, could not be applied for the fossils, as this shell part usually is too strongly damaged.

Table 7. Long diameter (A), whorl formula and number of whorls for seven specimens of *Atlanta oligogyra* Tesch, 1906 from the locality Anda1.

Specimen	A (mm)	A : B : C	number of whorls
1	1.24	1 : 0.23 : 0.13	$3\frac{1}{2}$
2	1.20	1 : 0.23 : 0.13	$3\frac{1}{4}$
3	1.02	1 : 0.27 : 0.14	$3\frac{1}{4}$
4	1.00	1 : 0.26 : 0.13	3
5	0.88	1 : 0.29 : 0.14	3
6	0.84	1 : 0.29 : 0.14	3
7	0.70	1 : 0.33 : 0.18	$2\frac{3}{4}$

***Atlanta peroni* Lesueur, 1817**

Pl. 11, fig. 4; Pl. 12, figs. 1-3.

- * 1817 *A(tlanta) peroni* Lesueur, p. 390, pl. 2, fig. 1.
- . 1955 *Atlanta peroni* Lesueur: Tokioka, p. 228, pl. 15, figs. A-D, F-H.
- . 1966 *Atlanta peroni* Lesueur: Frontier, p. 132, figs. 1-5.
- . 1968 *Atlanta peronii* Lesueur: Richter, p. 12, figs. 6b, 7.
- ? 1972 *Atlanta okinawana* Noda n. sp., p. 481, pl. 57, fig. 21.
- . 1973 *Atlanta peroni* Lesueur: Thiriôt-Quévieux, p. 238, 252, fig. 1C.
- non 1974 *Atlanta peroni* Lesueur: Richter, p. 64, pl. 2, fig. 7 (= *Atlanta frontieri* Richter, 1993).
- . 1976b *Atlanta peroni* Lesueur: van der Spoel, p. 141, fig. 135 (with extensive synonymy).
- . 1989 *Atlanta peroni* Lesueur: Lalli & Gilmer, colour fig. 2.
- . 1990 *Atlanta peroni* Lesueur: Seapy, p. 118, figs. 4E-H, 6C.
- . 1993 *Atlanta peroni* Lesueur: Richter, p. 190, pl. 1, fig. 1, pl. 2, fig. 5.
- . 1999 *Atlanta peroni* Lesueur: Richter & Seapy, p. 638, figs. 1D, 7B.
- . 2001 *Atlanta peroni* Lesueur: Seapy & Skoglund, p. 35.
- . 2003 *Atlanta peronii* Lesueur: van der Linden, p. 131, fig. 4.

Description – The largest available specimen (in sample Anda4) reaches a diameter of 4.88 mm, less than half the maximum size (10 mm) of Recent specimens of *Atlanta peroni*. In all shells the body whorl and the penultimate one are connected, without the keel inserting in between. In the species *A. fragilis* Richter, 1993, *A. rosea* Souleyet, 1852a, and *A. frontieri* Richter, 1993, all belonging to the same *Atlanta peroni* species group (Richter & Seapy, 1999, table 4), the younger whorls separate much earlier than in *A. peroni*, leading to the conclusion that the present specimens belong to this latter species indeed. This was acknowledged by comparison with Recent specimens.

The protoconch has three whorls; the fourth whorl is expanding more rapidly. Usually, a thin spiral lira is present on the whorls of larval shells in the present samples, at or just above the place where the suture of the next whorl will attach (poorly visible in Pl. 12, fig. 2). In larger specimens this spiral is difficult to observe on the whorl surface, very close to the lower suture or is even covered by the next whorl. A very similar observation was also made by Frontier (1966, figs. 3, 4).

Richter (1974, p. 64, pl. 2, fig. 7 left), in his description of *Atlanta peroni*, referred to a spiral, situated higher on the whorl, closer to the upper suture than to the lower one. Although Richter described this feature in 1974 as ‘zuverlässiges Merkmal’ (reliable characteristic), the same author (1993, p. 190) described the protoconch whorls of *A. peroni* as smooth. Seapy (1990, p. 120) discussed the same feature and Richter (1993, p. 192) described the form with the subsutural spiral as a new species, *A. frontieri*. A further weak spiral is usually present much lower on the whorl, separating the base of the shell and developing in more adult specimens to the keel.

Measurements – The whorl formula, the long diameter (A) and the number of whorls are given for 20 specimens in Table 8. The figures for the whorl formula agree perfectly with data given by Tokioka (1955, p. 228), but the number of whorls related to the long diameter (A-value) in the fossil specimens on the average is half a whorl less. This may be caused by a different whorl counting method.

Table 8. Long diameter (A), whorl formula and number of whorls for 20 specimens of *Atlanta peroni* Lesueur, 1817, from locality Anda2.

Specimen	A (mm)	A : B : C	number of whorls
1	4.12	1 : 0.34 : 0.09	4 $\frac{3}{4}$
2	3.88	1 : 0.30 : 0.11	-
3	3.88	1 : 0.30 : 0.10	4 $\frac{3}{4}$
4	3.76	1 : 0.31 : 0.10	4 $\frac{1}{2}$
5	3.48	1 : 0.29 : 0.10	4 $\frac{1}{2}$
6	3.36	1 : 0.29 : 0.09	4 $\frac{1}{2}$
7	3.04	1 : 0.31 : 0.13	-
8	2.80	1 : 0.29 : 0.13	4 $\frac{1}{2}$
9	2.60	1 : 0.31 : 0.12	-
10	2.48	1 : 0.30 : 0.14	4 $\frac{1}{4}$
11	2.44	1 : 0.30 : 0.13	4 $\frac{1}{4}$
12	2.44	1 : 0.28 : 0.12	-
13	2.36	1 : 0.30 : 0.14	4 $\frac{1}{4}$
14	2.12	1 : 0.29 : 0.13	-
15	1.76	1 : 0.30 : 0.14	-
16	1.76	1 : 0.30 : 0.15	4
17	1.64	1 : 0.30 : 0.14	3 $\frac{3}{4}$
18	1.36	1 : 0.34 : 0.15	3 $\frac{3}{4}$
19	1.36	1 : 0.30 : 0.17	3 $\frac{3}{4}$
20	1.16	1 : 0.36 : 0.19	-

Material examined – Anda1, RGM 517 459 (many); Anda2, RGM 517 455 (many); RGM 517 456 (1), RGM 517 460 (20, measured specimens), RGM 539 766 (1; Pl. 11, fig. 4, Pl. 12, fig. 1), RGM 539 767 (1; Pl. 12, fig. 2), RGM 539 768 (1; Pl. 12, fig. 3); Anda3, RGM 517 457 (22); RGM 517 458 (many juveniles), RGM 517 461 (many); Anda4, RGM 517 462 (3); Anda6, RGM 517 463 (9), RGM 517 464 (1); AndaClif1, RGM 429 274 (12 juveniles); AndaClif3, RGM 429 310 (3 juveniles); AndaDeVos, RGM 517 465 (8); Roxas, RGM 517 466 (1, 4 juveniles); Tiep2, RGM 517 467 (4); Tiep 4, RGM 517 468 (3 juveniles).

Discussion – All four species in the *Atlanta peroni* species group have a slightly elevated protoconch with a smooth surface (but see above) and the adult whorls are more or less separated from each other. Distinction from the *Atlanta gaudichaudi* Souleyet, 1852a group is possible by means of the whorl formula, which for the Pangasinan material (see measurements) excludes *A. gaudichaudi*, as well as the related species *A. plana* and *A. echinogyra*.

It might very well be that the species *Atlanta okinawana* Noda, 1972 (p. 481, pl. 57, fig. 21), described from the Japanese Pliocene, belongs to the present species, but on the basis of description and illustration (of the umbilical side only) this cannot be taken for granted. In the extant fauna, *Atlanta peroni* has a circumglobal tropical and subtropical distribution (van der Spoel, 1976b, fig. 226). This is the first certain record of Cainozoic specimens.

***Atlanta plana* Richter, 1972**

Pl. 12, figs. 4, 5; Pl. 13, fig. 1.

- * 1972 *Atlanta plana* Richter n. sp., p. 90, figs. 6, 8.
- . 1974 *Atlanta plana* Richter: Richter, p. 68, fig. 8d, pl. 2, fig. 6.
- . 1976b *Atlanta plana* Richter: van der Spoel, p. 150, fig. 151.
- . 1987 *Atlanta plana*. Richter: p. 182, pl. 1, figs. 1-2, pl. 2, fig. 13, pl. 3, figs. 29, 30, pl. 5, figs. 35, 38.
- . 1990 *Atlanta plana* Richter: Seapy, p. 120, figs. 3A-B, 6E, 8A-D.
- . 2001 *Atlanta plana* Richter: Seapy & Skoglund, p. 36.
- v. 2004 *Atlanta* sp.: Janssen, p. 108. figs. 2, 3.

Description – In particular, juvenile specimens of this species resemble *Atlanta lesueuri* (especially also from the umbilical side), but can be distinguished by their more elevated protoconch of $3\frac{1}{4}$ whorls instead of $2\frac{1}{4}$ - $2\frac{3}{4}$. Furthermore, these have an ornamentation starting on the first whorl with some six irregular spirals of which two weak spiral lirae remain on the further protoconch whorls (Pl. 12, fig. 4c; Pl. 13, fig. 1b) and a stronger third one just above the suture. Below the suture extremely fine and irregular spirals are seen, and a somewhat stronger one separating the base of the shell (Pl. 12, fig. 5). The fourth whorl expands rapidly, but considerably more so and more inflated in the species *A. lesueuri*.

Material examined – Anda2, RGM 517 469 (2), RGM 539 769 (1; Pl. 12, fig. 4); Anda6, RGM 517 470 (1); AndaClif1, RGM 429 269 (1); Tiep3, RGM 517 471 (1, 2 juveniles); Anda5, RGM 517 472 (7 juvenile); Tiep5, RGM 539 770 (1; Pl. 12, fig. 5), RGM 539 771 (1; Pl. 13, fig. 1).

Measurements – The long diameter (A), the whorl formula, and the number of whorls were measured on six specimens (Table 9).

Discussion – Richter (1974, pp. 68, 70) pointed to the resemblance of *Atlanta plana* and *A. gaudichaudi*. Seapy (1990, p. 120) also stated that *Atlanta plana* is most similar in appearance to *A. gaudichaudi* and that both these species are perhaps most similar to *A. peroni*. In all these species, the rapidly expanding whorl is the fourth. Differences are mainly found in anatomical characteristics of little use for fossils. Still, as stated above, *A. plana* has, and *A. peroni* may have, spiral lira on their early whorls and the shape of the protoconch offers sufficient characteristics to separate these species. Specimens of

Table 9. Long diameter (A), whorl formula and number of whorls for six specimens of *Atlanta plana* Richter, 1972.

Specimen	locality	A (mm)	A : B : C	number of whorls
1	Anda2	1.52	1 : 0.24 : 0.13	4
2	Tiep3	1.40	1 : 0.26 : 0.14	4
3	Anda2	1.40	1 : 0.26 : 0.15	3 $\frac{1}{2}$
4	Anda6	1.20	1 : 0.30 : 0.16	3 $\frac{1}{2}$
5	AndaClif1	1.16	1 : 0.27 : 0.15	3 $\frac{1}{4}$
6	Anda2	0.90	1 : 0.32 : 0.19	3 $\frac{1}{4}$

A. lingayanensis sp. nov, described above, with two spirals on the early whorls may be mistaken for *A. plana*, but the shape of the larval shell is clearly different (compare Pl. 10, fig. 4, and Pl. 12, fig. 5).

The specimens recorded by Janssen (2004, figs. 2, 3) from the Pliocene of Spain are here attributed to *A. plana* as well. Their shape and ornament agree completely with the SEM images given by Seapy (1990). The occurrence in the Mediterranean Pliocene, however, remains curious, as to date it is the one and only record from the Atlantic realm. Richter (1972, 1987) and van der Spoel (1976b, map fig. 233) recorded *Atlanta plana* only from the Indian Ocean. Seapy (1990, p. 120), however, also referred to Pacific occurrences near Hawaii and Australia.

***Atlanta richteri* sp. nov.**

Pl. 13, figs. 2-4; Pl. 14, figs. 1, 2.

Holotype – RGM 517 474 (Pl. 14, fig. 2).

Type locality – Anda2, Cabarruyan Island (Pangasinan, Philippines), coastal cliff section at co-ordinates c. N 16° 17.413' E 119° 56.197', map-sheet 6975-I, Bolinao (Fig. 1).

Stratum typicum – Greyish-brown marlstone, in interbedded sandstone, siltstone and claystone, below Bolinao Limestone, Pliocene.

Derivatio nominis – Named after Dr Gotthard Richter (SMF), in recognition of his longstanding and critical research on Recent Atlantidae.

Paratypes – Anda1, RGM 517 473 (1, 1 juvenile); Anda2, RGM 517 475 (2, 2 juveniles); Anda3, RGM 517 476 (3, 9 juveniles), RGM 539 772 (1; Pl. 13, fig. 2), RGM 539 773 (1; Pl. 13, fig. 3); Anda4, RGM 517 477 (3, 9 juveniles), RGM 539 774 (1; Pl. 13, fig. 4), RGM 539 775 (1; Pl. 14, fig. 1); AndaClif1, RGM 429 273 (5 juveniles); AndaClif3, RGM 429 309 (5 juveniles); Roxas, RGM 517 478 (1 juvenile); Tiep3, RGM 517 480 (4 juveniles); Tiep4, RGM 517 481 (1 juvenile); Tiep5, RGM 517 479 (3, 10 juveniles).

Diagnosis – *Atlanta* species with a protoconch of 3¾ to almost 4 tightly coiled whorls, together forming a depressed conical spire, the first two whorls of which are narrower than the nucleus. The whorl expanding more rapidly is the fifth.

Description – This species is characterised by its protoconch of 3¾-4 whorls attaching high on the foregoing whorl. This results in an apical spira with a low conical shape, with the second and third whorl (apical view) even narrower than the relatively wide nucleus (diameter approximately 45-50 µm). The nucleus, when strongly enlarged (Pl. 14, fig. 2c), seems to be very finely granulated, but this may be the result of corrosion. The subsutural zone of the protoconch whorls is separated by a thin spiral line, that disappears under the next whorl, attaching slightly above this spiral. Because of a very slight oblique position of the larval shell, this spiral may be visible again on part of the last protoconch whorl. Two or three weak spiral lirae may be visible between the upper and the lower sutures on the protoconch, weakening slowly and disappearing on the

fourth whorl. The sides of the protoconch have a number of spiral lirae that sometimes are so weak that the shell looks smooth. The base of some juvenile shells is separated by a slightly stronger spiral, but it can also be gradually rounded. The boundary with the teleoconch is not very clear. The fourth protoconch whorl slowly gets a bit wider, but it is the first teleoconch whorl that expands more rapidly and becomes dorso-ventrally flattened, with a flange-like keel encircling the body whorl. The somewhat stronger spiral just below the suture changes to a superficial furrow on the initial part of the teleoconch. In the available specimens the last whorl does not separate from the penultimate whorl. Some vague transverse folds are seen on the last quarter of the body whorl.

Measurements – The long diameter (A), the whorl formula and the number of whorls of the holotype and eleven paratypes were measured (Table 10).

Discussion – The low conical spire of the protoconch, as well as the fact that it is the fifth whorl that expands more rapidly, relates *A. richteri* to the *Atlanta inflata* group of Richter & Seapy (1999). In none of the species in this group, however, does the protoconch have such a depressed shape, nor are the first whorls so narrow compared to the nucleus (compare Seapy, 1990, fig. 11C). In Recent species of this group the inner shell wall of adult specimens is dissolved, but even in broken specimens among the present material this could not be seen with certainty, as the shells are always filled with matrix. *Atlanta helicinoides*, which also has quite narrow early whorls, has a more dome-shaped protoconch and the ornamentation is different (compare Seapy, 1990, fig. 11E-H). Also, the early protoconch whorls may seem to be narrower than the nucleus of the protoconch in *Atlanta gaudichaudi* (e.g., Seapy & Richter, 1993, fig. 9c), but in that species the protoconch is much higher and turreted, and the whorl expanding more rapidly is the fourth.

***Atlanta seapyi* sp. nov.**
Pl. 14, fig. 3; Pl. 15, figs. 1-3.

Holotype – RGM 517 482 (Pl. 14, fig. 3).

Table 10. Long diameter (A), whorl formula and number of whorls for the holotype and eleven paratype specimens of *Atlanta richteri* sp. nov.

Specimen	locality	A (mm)	A : B : C	number of whorls
1	Anda2	1.22	1 : 0.35 : 0.20	5
2 (holotype)	Anda3	1.20	1 : 0.35 : 0.21	5
3	Anda4	1.12	1 : 0.32 : 0.19	4 $\frac{3}{4}$
4	Anda1	1.04	1 : 0.34 : 0.19	4 $\frac{3}{4}$
5	Anda3	1.02	1 : 0.35 : 0.20	4 $\frac{3}{4}$
6	Anda4	1.02	1 : 0.34 : 0.19	4 $\frac{1}{2}$
7	Anda2	0.98	1 : 0.36 : 0.19	4 $\frac{3}{4}$
8	Anda4	0.96	1 : 0.38 : 0.22	4 $\frac{3}{4}$
9	Tiep5	0.86	1 : 0.40 : 0.21	4 $\frac{1}{2}$
10	Anda3	0.84	1 : 0.41 : 0.23	4 $\frac{1}{2}$
11	Anda4	0.84	1 : 0.40 : 0.21	4 $\frac{1}{2}$
12	Anda3	0.62	1 : 0.42 : 0.24	4 $\frac{1}{4}$

Type locality – Anda1, Cabarruyan Island (Pangasinan, Philippines), coastal cliff section at co-ordinates c. N 16° 17.413' E 119° 56.197', map-sheet 6975-I, Bolinao (Fig. 1).

Stratum typicum – Greyish-brown marlstone, in interbedded sandstone, siltstone and claystone, below Bolinao Limestone, Pliocene.

Derivatio nominis – Named after Professor Roger R. Seapy, California State University, Fullerton, U.S.A., who contributed substantially to the research of Recent heteropods and kindly gave his opinion on the identification of the present Atlantidae samples.

Paratypes – Anda3, RGM 517 483 (2 juveniles); AndaClif1, RGM 429 275 (1 juvenile); AndaClif3, RGM 539 779 (1; Pl. 15, fig. 2); Tiep3, RGM 517 484 (3, 3 juveniles), RGM 539 778 (1 juvenile; Pl. 15, fig. 1); Tiep5, RGM 517 485 (6 juveniles), RGM 539 780 (1; Pl. 15, fig. 3).

Diagnosis – *Atlanta* species with a protoconch of 5 whorls with a completely flat sub-sutural zone, separated by a keel, together forming a rather elevated spire with concave tangents. The whorl expanding more rapidly is the sixth.

Description – The protoconch has five whorls, starting from a rather voluminous nucleus. The first embryonic whorl sometimes has a weak carina, close to the upper suture, that soon disappears. A further, stronger carina is present a bit lower on the whorl, separating a smooth and flat subsutural zone. It is developed as a sharp spiral ridge, which remains visible just above the lower suture (Pl. 14, fig. 3d). Protoconchs up to three whorls are as high as wide (Pl. 15, figs. 2a, 3), but larger specimens become gradually wider than high. Their carina is less sharp and disappears on the more rapidly widening teleoconch whorl. This results in an apical spire with distinctly concave tangents; near the end of the protoconch the apical plane becomes flatter. Apparently, the axis of the larval shell does not deviate from the teleoconch's axis. A further, much weaker spiral is present around the narrow umbilicus of the protoconch, developing on the teleoconch into the keel, which in the available material is not preserved as a flange, as the specimens are not adult.

Measurements – Of the two specimens having $\frac{1}{4}$ teleoconch whorl, the long diameter and the whorl formula were measured (Table 11).

Discussion – Unfortunately, not a single completely adult specimen is available. The two largest specimens have just a quarter of a whorl behind the protoconch and in one

Table 11. Long diameter (A), whorl formula and number of whorls for the holotype and one paratype of *Atlanta seapyi* sp. nov.

Specimen	locality	A (mm)	A : B : C	number of whorls
1 (holotype)	Anda1	1.18	1 : 0.48 : 0.31	-
2 (paratype)	Anda3	0.90	1 : 0.51 : 0.35	5 $\frac{1}{4}$

of these, the holotype, the earliest whorls are missing. Still, there are sufficient juvenile specimens indicating that this is a new atlantid species, unrelated to any of the known Recent species.

There are just two species of Recent atlantids with a protoconch of five whorls and with the sixth whorl widening more rapidly, *viz.* *Atlanta tokiokai* (see below) and *A. me-teori* Richter, 1972, which both have a completely different protoconch morphology (compare Richter, 1990, pls. 1-3). *Atlanta frontieri* Richter (1993, p. 192) has a similar shape of the embryonic whorls and also a carina along the suture. The shape of the larval shell, however, is clearly more squarish (Richter, 1993, pl. 2, fig. 7) and the whorl expanding more rapidly is the fifth.

Atlanta tokiokai van der Spoel & Troost, 1972

Pl. 15, figs. 4, 5; Pl. 16, fig. 1.

- * 1972 *Atlanta tokiokai* van der Spoel & Troost nov. spec., p. 2, figs. 1-3.
- . 1974 *Atlanta inclinata* Souleyet: Richter, p. 70, pl. 3, fig. 11 (*non* Souleyet).
- . 1976b *Atlanta tokiokai* van der Spoel & Troost: van der Spoel, p. 148, figs. 147, 148 (with earlier synonyms).
- . 1990 *Atlanta tokiokai* van der Spoel & Troost: Richter, p. 262, pl. 1, figs. 1, 2, 9, pl. 2, figs. 13, 14, pl. 3, figs. 21, 25, 27-29.
- . 1990 *Atlanta tokiokai* van der Spoel & Troost: Seapy, p. 126, figs. 5D, 6K, 12A-D.
- . 1999 *Atlanta tokiokai* van der Spoel and Troost: Richter & Seapy, p. 639, figs. 1F, 7E.
- . 2001 *Atlanta tokiokai* van der Spoel & Troost: Seapy & Skoglund, p. 35.
- . 2003 *Atlanta tokiokai* Van der Spoel & Troost: van der Linden, p. 132, fig. 7.

Description – The protoconch of this species has five slightly convex to almost flat whorls, separated by very superficial sutures. Two spiral lines are present, one just above the place where the suture of the next whorl attaches and one lower on the whorl, below the periphery. This latter spiral develops into the keel of the adult shell. On the protoconch whorls these spirals cause a very slight angularity of the whorls. The complete protoconch is covered with a micro-ornament, consisting of spirally arranged granules; to a lesser degree this is also present on the teleoconch. On the base of the protoconch these granules are developed as short and obliquely elongated pustules. The first whorl of the teleoconch increases suddenly in width and attaches high onto the protoconch, in such a way that the latter seems to be situated very obliquely within the teleoconch whorls. Because of this position the basal part of the last protoconch whorl protrudes distinctly beyond the base of the shell, making the adult shell more or less symmetrical (compare also Richter, 1990, figs. 1, 14). The last part of the body whorl separates from the preceding whorl; the space is filled with the extremely thin and fragile keel that encircles the greater part of the body whorl.

Measurements – Because of the oblique position of the protoconch the whorl formula cannot be measured correctly in this species. The maximum shell diameter observed in the Pangasinan material is 3.44 mm, but the bulk of the specimens consists of much smaller, predominantly larval shells.

Material examined – Anda1, RGM 517 486 (1); Anda2, RGM 517 487 (many); Anda3, RGM 517 488 (many), RGM 539 781 (1; Pl. 15, fig. 4), RGM 539 849 (1; Pl. 15, fig. 6, Pl. 16,

fig. 1); Anda4, RGM 517 489 (many); Anda6, RGM 517 490 (1); AndaClif1, RGM 429 276 (25 juveniles); AndaDeVos, RGM 517 491 (1); Tiep3, RGM 517 492 (1); Tiep4, RGM 517 493 (3 juveniles); Tiep5, RGM 517 494 (2 juveniles).

Discussion – *Atlanta tokiokai* has a rather complicated nomenclatural history, sorted out by Richter (1990, pp. 262, 263), who included it in the *Atlanta inclinata* Souleyet, 1852a species group, in which he accepted, apart from these two taxa, also *A. gibbosa* Souleyet, 1852a, and *A. meteori* Richter, 1990. Richter & Seapy (1999), however, included the two last-named species in a separate *A. gibbosa* species group.

Comparing the illustrations in the literature (see synonyms) demonstrates that the material here referred to does not belong to either *Atlanta gibbosa* or *A. meteori*. Not only are the larval shells differently shaped and ornamented (Richter, 1990, pls. 1-3), but also the teleoconch whorls of these species separate much earlier and in both the body whorl shows distinct transverse folds. The distinction between *A. inclinata* and *A. tokiokai* was possible as the latter has a larger protoconch of five instead of four whorls, and a flat instead of a convex base. The fossil specimens agree very well with compared Recent material of *A. tokiokai*, but Professor Seapy concluded that the spiral ridge is much more strongly raised in the Pangasinan specimens than in Recent ones from Hawaii.

Atlanta tokiokai is known in the Recent fauna from the Caribbean, from the tropical Atlantic, the Indian Ocean and a single record from Indonesia (van der Spoel, 1976b, fig. 233; Richter, 1990). Richter & Seapy (1999) and Seapy & Skoglund (2001) give its distribution as circumglobal at tropical to subtropical latitudes. These are the first records of fossil specimens of this taxon.

Genus *Oxygyrus* Benson, 1835

Type species – *Oxygyrus inflatus* Benson, 1835 = *O. keraudreni* (Lesueur, 1817) (Recent)

Oxygyrus keraudreni (Lesueur, 1817)

Pl. 1, figs. 2, 3; Pl. 16, figs. 2-4.

- * 1817 *A(tlanta) Keraudrenii* Lesueur, p. 391, pl. 2, fig. I.
- v. 1972 *Atys (Sphaeratys) globulinus* Nordsieck n. sp., p. 29, pl. O IV, fig. 20 (mala).
- . 1973 *Oxygyrus keraudreni* (Lesueur): Thiriot-Quévieux, p. 238, 250, figs. 1A, 6A.
- . 1974 *Oxygyrus keraudreni* (Lesueur): Richter, p. 71.
- . 1976b *Oxygyrus keraudreni* (Lesueur): van der Spoel, p. 137, figs. 133, 224 (with extensive synonymy).
- . 1976 *Oxygyrus keraudreni* (Lesueur): Batten & Dumont, p. 279, figs. 15-25.
- . 1990 *Oxygyrus keraudreni* (Lesueur): Seapy, p. 111, fig. 3E-H.
- v. 1998 *Oxygyrus keraudreni* (Lesueur): Janssen, p. 98, pl. 1, fig. 3a-b.
- . 1999 *Oxygyrus keraudreni* (Lesueur): Richter & Seapy, p. 633, fig. 5B.
- v. 2003 *Oxygyrus keraudreni* (Lesueur): van der Linden, p. 130, fig. 1 (*non* fig. 2).
- v. 2004 *Oxygyrus keraudreni* (Lesueur): Janssen, p. 106, pl. 2, fig. 1a-c.
- v. 2004 *Oxygyrus keraudreni* (Lesueur): Faber, p. 72, fig. 1.

Description – The shell of this easily recognisable species is completely involute, with a similar ‘umbilicus’ at both the top and the base of the shell. This feature makes it impossible to count the number of protoconch whorls, as only one is visible in each of

them. The juvenile shell initially is slightly wider than high, but gets relatively wider during growth. Its surface is slightly irregularly covered with approximately 20-24 spiral lirae in a zigzag-shape that usually leave a narrow zone free just below the periphery (not yet so in very juvenile specimens, compare Pl. 16, figs. 3a and 4). In between these lirae the shell's surface is granulated (Pl. 16, fig. 3b). The apertural margin of the shell is deeply sinuated, as can be seen from the shape of the growth lines and also at the place where the ornamented protoconch changes quite suddenly to the much less clearly ornamented teleoconch (this transition is well-illustrated by Thiriot-Quévieux, 1973, fig. 1A, and Batten & Dumont, 1976, fig. 24). In the largest available specimen (from Anda4, $W = 3.24$ mm), the teleoconch has one complete whorl, widening rapidly, which makes the shell about twice as wide as high. In this specimen the apertural margin is irregularly broken, indicating that the teleoconch might even have more than one calcified teleoconch whorl in complete specimens. In a specimen from Anda1 ($H = 1.60$, $W = 2.52$ mm), the teleoconch has three quarters of a whorl. On the post-larval shell a vague spiral ornament is present and the peripheral belt remains visible as a slightly produced zone reaching the apertural margin.

Material examined – Anda1, RGM 517 505 (many), RGM 539 782 (1; Pl. 16, fig. 2), RGM 539 783 (1; Pl. 16, fig. 3), RGM 539 784 (1; Pl. 16, fig. 4); Anda2, RGM 517 506 (many); Anda3, RGM 517 507 (many); Anda4, RGM 517 508 (many), RGM 517 510 (1; Pl. 1, fig. 3); Anda6, RGM 517 509 (1); AndaClif1, RGM 429 279 (23); AndaClif3, RGM 429 313 (17); Roxas, RGM 517 511 (5); Tiep1, RGM 517 512 (5); Tiep2, RGM 517 513 (19); Tiep3, RGM 517 514 (7); Tiep4, RGM 517 515 (7); Tiep5, RGM 517 516 (8).

Discussion – The nucleus and early whorl of *Oxygyrus keraudreni* are only visible in very juvenile specimens (Richter, 1968, fig. 15; Batten & Dumont, 1976, figs. 17, 21). Larger juvenile specimens of this species are common in most of the Pangasinan samples. From the fossil record this species was known, in very few specimens only, from Jamaica (Janssen, 1998) and the Mediterranean Pliocene (Italy, Spain, France; Janssen, 2004). The French occurrence was dated as Zanclean and thus it may be assumed that *Oxygyrus* occurred approximately since the Miocene-Pliocene transition. Miocene representatives or related forms are unknown to date.

Recent specimens of *Oxygyrus keraudreni* have an uncalcified shell of conchiolin in the adult stage. Seapy (1990, fig. 3E-F) illustrated such a shell with a diameter of just 2.2 mm. In this specimen the boundary between protoconch and teleoconch is visible, with the transition from calcareous to conchiolin shell just in front of this boundary. In this SE micrograph it is not possible to see if, or how far, the calcareous shell continues under the conchiolin sheet, but this cannot be more than half a whorl. Similarly, the calcareous teleoconch comprises less than half a whorl in the illustrations of Thiriot-Quévieux (1973, fig. 1A) and Batten & Dumont (1976, fig. 24). This makes the large specimen from Anda4, with a diameter of 3.4 mm and a complete calcareous teleoconch whorl, quite remarkable. It indicates that, during the Pliocene, individuals of this species were yet further calcified than are extant specimens. This could point to a developmental trend involving a reduction of calcareous matter in the course of time, as a gradual weight reduction beneficial for holoplanktonic life. The distinct peripheral belt demonstrates that a conchiolin keel was present.

One might argue that the presence of a completely calcified body whorl is sufficient reason for the erection of a new taxon. In the opinion of the present author, considering that juvenile specimens are completely identical with Recent specimens, this phenomenon presents insufficient evidence and the available material is inadequate.

Faber (2004) presumed *Atys* (*Sphaeratys*) *globulinus* Nordsieck, 1972, based on a single Recent specimen from Ibiza, Mediterranean (here re-illustrated; Pl. 1, fig. 2), to be a juvenile shell of the present species. This could be acknowledged by an inspection of the holotype. The main difference mentioned by Nordsieck (spiral furrows, instead of spiral ridges) could not be substantiated. Although difficult to distinguish in the very transparent specimen, the fine spirals are exactly the same as in *O. keraudreni* and show the same zigzag structure. As in typical *Oxygyrus*, there is a zone without spirals just below the periphery. The author is grateful to Dr Ronald Janssen (SMF) for the loan of the type specimen.

Genus *Protatlanta* Tesch, 1908

Type species – *Protatlanta souleyeti* (Smith, 1888) (Recent).

Protatlanta rotundata (Gabb, 1873)

Pl. 1, fig. 1; Pl. 17, figs. 1-3

- non 1867 *Atlanta rotundata* (sic) d'Orbigny: Reuss, p. 146 [= *Atlanta rotunda* d'Orbigny, 1836 = *Limacina helicina* (Phipps, 1774) forma *rangii* (d'Orbigny, 1836)].
- *v 1873 *Atlanta rotundata* Gabb n.s., p. 201.
- . 1882 *Atlanta rotundata* Gabb: Guppy, p. 175 (reprinted in Harris, 1921, p. 244).
- v. 1922 *Atlanta rotundata* Gabb: Pilsbry, p. 314, fig. 15.
- v. 1928 *Atlanta* (*Atlantidea*) *lissa* Woodring new species, p. 134, pl. 2, figs. 26, 27.
- . 1984 *Protatlanta kakegawaensis* Shibata n. sp., p. 75, pl. 23, figs. 1-3.
- v. 1998 *Protatlanta lissa* (Woodring): Janssen, p. 98, pl. 1, figs. 4-5.
- v. 1999a *Protatlanta rotundata* (Gabb): Janssen, p. 12, pl. 2, figs. 3-4.
- v. 1999b *Protatlanta rotundata* (Gabb): Janssen, fig. 1a-c.
- v. 2004 *Protatlanta rotundata* (Gabb): Janssen, p. 107, pl. 2, fig. 2a-b.

Description – See Janssen (2004). Part of the material in the present samples is excellently preserved and includes various juvenile specimens (Pl. 17, figs. 2, 3). The larval shell is globular, about as wide as high and has approximately five whorls which attach very high onto the preceding whorl. In apical view, therefore, the second and third whorls are very narrow, even much narrower than the nucleus and first whorl of the protoconch. The fifth whorl gradually attaches somewhat lower on the penultimate whorl. All protoconch whorls have a number of very narrow, distant and thread-like spiral lirae with a zigzag structure, just one of which remains visible between the upper and lower sutures. One spiral at the place of the suture and a further one on the base of the protoconch are somewhat stronger developed, but do not or only faintly show the zigzag structure. The boundary with the teleoconch is indicated by a rather sudden disappearance of the ornament.

In the largest specimen (reaching a width of nearly 10 mm; Pl. 1, fig. 1) there are almost two teleoconch whorls that initially attach very high onto the protoconch, with the

result that the larval shell seems to be embedded rather obliquely within the younger whorls. The diameter of the teleoconch increases rapidly, the result being a shell that strongly resembles *Planorbarius* (but, of course, dextral). The surface of these younger whorls bears flexuous growth lines, and a dense and very fine, somewhat irregular spiral striation, only visible where light reflects on the shell. On the body whorl a distinct peripheral belt is present on which the growth lines are strongly bent backward, indicating a deep sinus in the apertural margin.

Material examined – Anda1, RGM 517 517 (8 juveniles); RGM 517 518 (1); Anda2, RGM 517 519 (3, 5 juveniles); Anda3, RGM 517 520 (2, 7 juveniles), RGM539.785 (1; Pl. 17, fig. 1), RGM 539 786 (1; Pl. 17, fig. 2), RGM 539 787 (1; Pl. 17, fig. 3); Anda4, RGM 517 521 (3 juveniles); Anda6, RGM 517 522 (1; Pl. 1, fig. 1); RGM 517 523 (2 juveniles); Anda-Clif1, RGM 429 272 (3 juveniles); AndaClif3, RGM 429 308 (8 juveniles); Roxas, RGM 517 524 (1 juvenile); Tiep3, RGM 517 525 (5 juveniles); Tiep4, RGM 517 526 (7 juveniles); Tiep5, RGM 517 527 (6 juveniles).

Discussion – *Protatlanta rotundata* differs considerably from the type of the genus, *P. souleyeti*. Not only does the adult shell in *P. rotundata* reach a diameter that is roughly five times that of *P. souleyeti*, but the morphology of its protoconch and the shape of the fully grown shell are utterly different. Also, as both species occur together in the Pangasinan samples, *P. rotundata* can certainly not be considered to be the ancestor species. The presence of a subperipheral belt much the same as in *P. souleyeti*, on the other hand, demonstrates that a conchiolin keel has been present in this species. Considering the generally accepted differences in protoconch morphology within the Atlantidae, a new genus is not introduced here.

Protatlanta rotundata was originally described from the (Late?) Miocene of the Dominican Republic (Gabb, 1873; Janssen, 1999a) and has a wide horizontal and vertical distribution; Langhian-Serravallian (Italy, Malta, Cyprus; RGM collections), Tortonian (Sicily), Piacenzian (Spain, Jamaica, Philippines) and 'Middle Pliocene-Early Pleistocene' (Japan).

***Protatlanta souleyeti* (Smith, 1888)**

Pl. 17, fig. 4; Pl. 18, figs. 1, 2.

- * 1888 *Atlanta souleyeti* Smith, p. 43.
- . 1941 *Protoatlanta (sic) souleyeti* (Smith): Wenz, p. 1015, fig. 2912.
- . 1968 *Protatlanta souleyeti* (Smith): Richter, p. 17, figs. 6c, 12, 14 (left).
- . 1973 *Proatlanta (sic!) souleyeti* (Smith): Thiriot-Quiévreux, p. 238, 250, fig. 1B.
- . 1974 *Protatlanta souleyeti* (Smith): Richter, p. 71, pl. 3, fig. 16.
- v. 1976b *Protatlanta souleyeti* (Smith): van der Spoel, p. 139, fig. 134 (with extensive synonymy).
- . 1976 *Protatlanta souleyeti* (Smith): Batten & Dumont, p. 288, figs. 39-47.
- . 1983 *Protatlanta souleyeti* (Smith): Shibata & Ujihara, p. 154, pl. 46, fig. 1a-c.
- . 1990 *Protatlanta souleyeti* (Smith): Seapy, p. 114, figs. 1A, 4A-D, 5A.
- v. 1999a *Protatlanta souleyeti* (Smith): Janssen, pl. 2, fig. 5a-c.
- . 1999 *Protatlanta souleyeti* (Smith): Richter & Seapy, p. 633, fig. 5A.
- . 2003 *Protatlanta souleyeti* (Smith): van der Linden, p. 130.

Description – Some of the fossil specimens preserve a pinkish colour of the larval shells. The protoconch is naticoid in shape and has approximately $3\frac{1}{4}$ whorls. Most specimens have two thin spirals above the periphery, visible in apical view, and a third such spiral (sometimes doubled; Pl. 17, fig. 4) below the periphery, which separates the base of the protoconch and becomes covered by subsequent whorls. In the present samples the described ornament is fairly constant, but some specimens were found (Pl. 18, fig. 2a-c) in which these three spirals are lacking (specified separately, below). Richter (1968, p. 17, fig. 6c) described Recent larval shells from the Gulf of Naples as smooth. For Recent material from near Hawaii, Seapy (1990, p. 114, fig. 4A-D) also stated that the first whorls are smooth. But Batten & Dumont (1976, figs. 39-41) and Richter & Seapy (1999, p. 633, fig. 5A) described two protoconch morphologies, agreeing with the present material. On the teleoconch whorls, the peripheral belt on which the conchiolin keel was attached is very clear. Growth lines are strongly bent backward on this belt, indicating the presence of a deep sinus on the apertural margin. A very faint spiral striation is visible all over the adult shell surface.

Measurements – Seventeen specimens could be measured (Table 12).

Material examined – Typical form: Anda1, RGM 517 528 (33); Anda2, RGM 517 529 (26); Anda3, RGM 517 530 (many), RGM 539 790 (1; Pl. 17, fig. 4); Anda4, RGM 517 531 (many), RGM 539 788 (1; Pl. 18, fig. 1); AndaClif1, RGM 429 270 (many juveniles), RGM 429 271 (1 juvenile); AndaClif3, RGM 429 306 (10 juveniles), RGM 429 307 (3 juveniles); AndaDeVos, RGM 517 532 (4); Roxas, RGM 517 533 (2 juveniles); Tiep3, RGM 517 534 (2); Tiep3, RGM 517 535 (2, 18 juveniles); Tiep4, RGM 517 536 (6 juveniles); Tiep5, RGM 517 537 (31 juveniles).

Table 12. Long diameter (A), whorl formula and number of whorls for 17 specimens of *Protatlanta souleyeti* (Smith, 1888), from locality Anda4.

Specimen	A in mm	A : B : C	number of whorls
1	2.56	1 : 0.24 : 0.11	4 $\frac{1}{4}$
2	2.24	1 : 0.21 : 0.11	4 $\frac{1}{4}$
3	2.24	1 : 0.22 : 0.12	4 $\frac{1}{4}$
4	2.04	1 : 0.26 : 0.12	4 $\frac{1}{4}$
5	1.96	1 : 0.26 : 0.11	4 $\frac{1}{4}$
6	1.92	1 : 0.24 : 0.14	4
7	1.92	1 : 0.35 : 0.17	4
8	1.88	1 : 0.31 : 0.11	4
9	1.68	1 : 0.25 : 0.14	4
10	1.44	1 : 0.31 : 0.16	3 $\frac{3}{4}$
11	1.44	1 : 0.26 : 0.13	3 $\frac{3}{4}$
12	1.36	1 : 0.25 : 0.11	3 $\frac{3}{4}$
13	1.24	1 : 0.34 : 0.16	3 $\frac{1}{2}$
14	1.20	1 : 0.34 : 0.16	3 $\frac{3}{4}$
15	1.16	1 : 0.24 : 0.11	3 $\frac{1}{2}$
16	1.16	1 : 0.29 : 0.15	3 $\frac{1}{2}$
17	1.16	1 : 0.31 : 0.17	3 $\frac{1}{2}$

Form without spirals on the protoconch: Anda1, RGM 517 538 (3 juveniles); Anda2, RGM 517 539 (1); Anda3, RGM 539 789 (1; Pl. 18, fig. 2); Anda4, RGM 517 540 (7).

Discussion – The available specimens are so similar to compared Recent material that their conspecificity is considered to be assured. This is the first record of Cainozoic specimens of this species.

Family Carinariidae de Blainville, 1818

Remarks – In this family three genera are distinguished in the extant fauna, *viz.* *Carinaria* Lamarck, 1801, *Cardiapoda* d'Orbigny, 1836 and *Pterosoma* Lesson, 1827. In *Carinaria* and *Pterosoma* the adult shell is capuliform with transverse ornament, in *Cardiapoda* the teleoconch is reduced to 'a flat, roughly triangular, membranous shell perpendicular on the aperture of the protoconch' (van der Spoel, 1976b, p. 157, fig. 160a-b). Larval shells in these genera, however, are very similar, but not yet described for all species. Excellent SE micrographs of the protoconchs of four carinariid species were published by Seapy & Thiriou-Quévieux (1994), clearly demonstrating the small morphological differences.

From the fossil record Wenz (1941, p. 1016) only referred to Eocene and younger *Carinaria* species. Several species (mainly Miocene) have been described in that genus. The genus *Striocarinaria* di Geronimo, 1974, characterised by the possession of additional radial ornament on the teleoconch, was introduced from the Italian Miocene. Bandel & Hemleben (1987), however, interpreted several occurrences from a German Jurassic locality as Carinariidae. Furthermore the Early Cretaceous species *Brunonia annulata* (Yokoyama, 1890), that used to be considered a hydroid, or a gastropod belonging to the Archaeogastropoda, was interpreted as a carinariid species by Kase (1988) and Dieni (1990), discussed also by Pacaud (2004).

In the Pangasinan material just two poorly preserved post-larval carinariid shells resembling *Carinaria lamarcki* are present, but larval shells are fairly common. These obviously represent two species, but could be identified to genus level only.

Genus *Carinaria* Lamarck, 1801

Type species – *Carinaria cristata* (Linné, 1767) (Recent).

Carinaria cf. lamarcki auct., Péron & Lesueur, 1810?

Pl. 1, fig. 4.

- * 1810 *Carinaire Lamarck*. Péron & Lesueur, p. 69, pl. 2, fig. 15.
 1976b *Carinaria lamarcki* Péron & Lesueur: van der Spoel, p. 152, figs. 152, 153 (with extensive synonymy).

Description – Just two specimens beyond protoconch stage are available, both too incomplete to be identified with certainty. One of these reaches a height of just 1.8 mm, the other one (Pl. 1, fig. 4) 6 mm. In the latter specimen just a few shell remnants are present, associated with an internal mould. The apical part is missing and only a few

shell fragments of the carina remain. Still, the specimen is sufficiently complete to see that most probably the long diameter of the aperture exceeded the shell height, a characteristic pointing to the species *Carinaria lamarcki*.

Material examined – Anda2, RGM 517 541 (1: Pl. 1, fig. 4); Anda3, RGM 517 542 (1).

A few tiny shell fragments of post larval shells are furthermore included in the collection as *Carinaria* sp.: Anda1, RGM 517 543 (1 fragment); Anda2, RGM 517 544 (3 fragments); Anda3, RGM 517 545 (1 fragment).

Discussion – Although the name *Carinaria lamarcki* is attributed to Péron & Lesueur (1810) by all authors, that name does not occur in their 1810 publication, where only the vernacular name ‘Carinaire Lamarck’ is mentioned in the explanation of pl. 2 (not pl. 3, as sometimes found in references). In the ‘Explication des planches ..’ the following statement is included: ‘.. en attendant qu’il nous soit possible de publier cette riche collection de peintures, il nous a paru nécessaire de faire graver au trait simple une espèce de chacun des genres qui doivent composer la belle famille don’t il s’agit.’ By this statement the name ‘Carinaire Lamarck’ can be considered a vernacular name according to ICZN Art. 1.3.5, as a ‘means for temporary reference and not for formal taxonomic use’, making Péron & Lesueur’s name unavailable, even if latinised. The first author validating the name ‘*Carinaria lamarckii*’ was Watson (1898, p. 278). By that time, however, a number of other names had been proposed for the same species by Bianco (1888), Smith (1888) and most probably several further authors as well.

Carinaria sp.

Pl. 20, figs. 3-5.

Description – Very small larval shells (W 2.0, H 1.3 mm), strongly resembling *Pterosoma* cf. *planum* (see below), but differing in a number of respects. Size and number of whorls are about the same, but they are slightly less convex and attach a bit lower on the preceding whorl and, therefore, the apical spire is more elevated than in *Pterosoma*. A narrow subsutural ridge is present, starting just after the first half whorl and continuing to on the third. This ridge is accompanied by a spiral line and, in between the ridge and the spiral, the surface of the shell seems to be finely perforate (Pl. 20, fig. 3c). Widely spaced radial lines are visible between the lower spiral and the suture (Pl. 20, fig. 3b). In some specimens the subsutural ridge reaches the apertural margin, but in most it disappears early on the third whorl. The nucleus and first half whorl are densely granulated, especially close to the suture. On the base of the shell short ridges are seen radiating from the umbilicus, closely resembling a similar ornamentation illustrated by Seapy & Thiriou-Quévieux (1994, figs. 3, 6, 9, 12) for the four Carinariidae species described by them.

Material examined – Anda1, RGM 517546 (10); Anda2, RGM 517 547 (11), RGM 539 794 (1; Pl. 20, fig. 3), RGM 539 795 (1; Pl. 20, fig. 4), RGM 539 796 (1; Pl. 20, fig. 5); Anda3, RGM 517 548 (23); Anda4, RGM 517 549 (9); AndaClif1, RGM 429 278 (6); Roxas, RGM 517 554 (3); Tiep2, RGM 517 550 (8); Tiep3, RGM 517 551 (4); Tiep4, RGM 517 552 (3); Tiep5, RGM 517 553 (5).

Discussion – The two *Carinaria* protoconchs illustrated by Seapy & Thiriot-Quévieux (1994, figs. 8-13) both have a very similar subsutural ridge on the second and third whorl. In *Carinaria galea* Benson, 1835 (figs. 8-10), additional spirals are present all over the whorls and in *C. japonica* Okutani, 1955 (figs. 11-13), radiating ornament is seen on the second whorl. In a few Recent specimens of *C. lamarcki* that were compared, however, the protoconch does not have a subsutural ridge.

Further comparisons with Recent species will be necessary to arrive at a specific identification. One cannot exclude the possibility that the few specimens described above as *Carinaria* cf. *lamarcki* and the protoconchs described here in reality represent one and the same taxon, which might be unnamed as of yet.

Genus *Pterosoma* Lesson, 1827

Type species – *Pterosoma planum* Lesson, 1827 (emend. Crosse, 1896) (Recent).

Pterosoma cf. *planum* Lesson, 1827

Pl. 18, fig. 3; Pl. 19, figs. 1-5; Pl. 20, figs. 1, 2.

- ?* 1827 *Pterosoma plana* N. Lesson, p. 415, pl. 10, figs. A1, A2 (not the shell).
- ? 1976b *Pterosoma planum* Lesson: van der Spoel, p. 156, fig. 159 (shell not illustrated) (with extensive synonymy).
- ? 1994 *Pterosoma planum*: Seapy & Thiriot-Quévieux, p. 339, figs. 2-4.

Description – Very small, dextral protoconchs, the largest specimens having a shell width of approximately 1.85 mm and a height of 1.25 mm, with the greatest width above the horizontal midline. The number of whorls is $3\frac{3}{4}$, slowly and regularly increasing in diameter. The nucleus is granulated close to the suture (Pl. 19, fig. 1). The whorls are convex initially, separated by incised sutures and attaching high onto the preceding whorl, but flattening on the last protoconch whorl. This results in a rather flat apical plane, with a just slightly protruding apical spire. In most specimens the surface of the whorls only bears growth lines, but occasionally some radiating lines or furrows are seen on the early whorls (Pl. 20, fig. 2b). A weak subsutural spiral may be present on the second whorl (Pl. 19, fig. 5b). The base of the shell is gradually rounded and has a narrow umbilicus, occupying one ninth of the shell width. Approximately 10-13 narrow ridges radiate from the edge of the umbilicus over a short distance onto the base of the shell (Pl. 19, fig. 3b). In some specimens the umbilical carina is accentuated by a spiral furrow. The aperture is slightly oval, slightly higher than wide, with its long axis situated obliquely.

Material examined – Anda1, RGM 517 555 (21); Anda2, RGM 517 556 (21), RGM 539 791 (1; Pl. 18, fig. 3; Pl. 19, fig. 1), RGM 539 792 (1; Pl. 19, fig. 2), RGM 539 793 (1; Pl. 19, fig. 3), RGM 539 797 (1; Pl. 19, fig. 4); Anda3, RGM 517 557 (19), RGM 539 799 (1; Pl. 20, fig. 2); Anda4, RGM 517 558 (7), RGM 539 798 (1; Pl. 19, fig. 5; Pl. 20, fig. 1); Anda6, RGM 517 559 (1); AndaClif1, RGM 517 560 (6); AndaClif3, RGM 429 312 (8); AndaDeVos, RGM 517 562 (1); Roxas, RGM 517 561 (7); Tiep1, RGM 517 563 (1); Tiep2, RGM 517 564 (9); Tiep3, RGM 517 565 (2); Tiep4, RGM 517 566 (7).

Discussion – The present specimens agree almost perfectly with the illustrations in Seapy & Thiriot-Quévieux (1994, pp. 2-4) of *Pterosoma planum* and it might very well be that the Pangasinan material belongs to that species indeed. Still, there are some minor differences, as for instance the spiral around the umbilical carina, which is absent in their SE micrograph. The radial ornament on the second whorl is described by these authors as ‘narrow and low radiating ridges,’ whereas in the present material those radials, if present at all, are either not so narrow or developed as furrows. From the accompanying *Carinaria* protoconchs (see above), the *Pterosoma* specimens are easily distinguished by their general shell form with a flat apical spire and by the absence of a distinct subsutural spiral on the early whorls.

Infraorder Ptenoglossa Gray, 1853
Superfamily Janthinoidea Lamarck, 1812
Family Janthinidae Lamarck, 1812
Genus *Janthina* Bolten in Röding, 1798

Type species – *Janthina janthina* (Linné, 1758) (Recent).

***Janthina (Janthina) prolongata* de Blainville, 1822**
 Pl. 1, figs. 5, 6.

- * 1822 *Janthina prolongata* de Blainville, p. 155.
- . 1953 *Janthina prolongata* Blainville: Laursen, p. 28, figs. 30-32 (with further synonyms).

Description – Just two specimens are available, one of which is a broken protoconch with part of the first teleoconch whorl (Pl. 1, fig. 6). The other specimen (Pl. 1, fig. 5) retains the last protoconch whorl and at least 2½ teleoconch whorls. The boundary between proto- and teleoconch is not visible because of the oblique position of the larval shell. The whorls are convex and attach low on the preceding one, together forming a turreted shell with distinct suture, slightly higher than wide. On the body whorl, growth lines run backwards from the upper suture and form a shallow sinus below the periphery. On earlier whorls this sinus is partly covered by the suture. The base of the shell is slightly flattened and has a narrow umbilicus, for the greater part covered by the reflected columella. The aperture is large and, in this juvenile specimen, a bit squarish, with the junction of columella and lower apertural margin forming an angle of almost 90°.

Material examined – Anda1, RGM 517 582 (1; Pl. 1, fig. 5), Anda2, RGM 517 583 (1 juvenile; Pl. 1, fig. 6).

Discussion – *Janthina* species are rarely recorded as fossils. Woodring (1928, p. 405) mentioned an unidentified juvenile specimen from the Bowden shell beds in Jamaica (Middle Pliocene). The species introduced as *Janthina cimbrica* Sorgenfrei (1958, p. 176, pl. 32, fig. 110) from the Danish Miocene was recognised as a cypraeid protoconch (Janssen, 1984, p. 195). The present restricted material cannot be distinguished from the Recent *J. prolongata*, distributed worldwide in tropical and subtropical areas.

Subclass Orthogastropoda Ponder & Lindberg, 1995
Superorder Heterobranchia Burmeister, 1837
Order Euthyneura Spengel, 1881
Suborder Thecosomata de Blainville, 1824
Infraorder Euthecosomata Meisenheimer, 1905
Superfamily Limacinoidea Gray, 1847
Family Limacinidae Gray, 1847
Genus *Heliconoides* d'Orbigny, 1836

Type species – *Heliconoides inflata* (d'Orbigny, 1836) (Recent).

***Heliconoides inflata* (d'Orbigny, 1836)**

Pl. 2, figs. 1-3; Pl. 21, figs. 1-3.

- * 1836 *Atlanta inflata* d'Orbigny, p. 174, pl. 12, figs. 16-19.
- . 1880 *Embolus rostralis* Souleyet (*Spirialis*): Seguenza, p. 277.
- v. 1887 *Spirialis tertiaria* Tate spec. nov., p. 196 [partim, *non* Tate, only pl. 20, fig. 12a-c; includes *Limacina tertiaria* (Tate)].
- v? 1934 *Limacina inflata* (d'Orbigny): Collins, p. 179, pl. 7, figs. 3-5 [partim, *non* figs. 6-8 = *Striolimacina imitans* Gabb].
- . 1967 *Limacina (Thilea) inflata* (Orbigny): van der Spoel, 1967, p. 50, figs. 17, 18 (with extensive synonymy of Recent occurrences).
- v? 1974 *Spiratella inflata* (d'Orbigny): Perrilliat, p. 34.
- v. 1990 *Limacina inflata* (d'Orbigny): Janssen, p. 14, pl. 2, figs. 5-7, pl. 3, fig. 11, pl. 10, fig. 2.
- v. 1999a *Limacina (Heliconoides) inflata* (d'Orbigny): Janssen, p. 14, pl. 2, figs 10, 11.
- . 2003 *Heliconoides inflata* (d'Orbigny): Janssen, p. 168.
- v. 2004 *Heliconoides inflata* (d'Orbigny): Janssen, p. 110, pl. 1, figs 4-6.

Description – See van der Spoel (1967) and Janssen (2004). Specimens of this species are abundantly present in all samples. Both Types A and B, as defined in Janssen (2004), are common, but Type A specimens, with an internal subperipheral belt (Pl. 21, fig. 3), are difficult to recognise because of the opaque shells. Most larger specimens belong to Type B, in which the falciform thickening sometimes also is difficult to see as the shells are not transparent and filled with matrix. In many cases, however, the last part of the bodywhorl, beyond the internal thickening, has a slightly smaller diameter (Pl. 21, fig. 1), rather than an outward bulging shell. This shell part is extremely fragile and broken in almost all specimens. Apertural fragments showing the internal thickening are not rare, as this is the most solid part of the shell. On the rostral part of the teleoconch an oblique micro-ornament is present, visible in a SE micrograph (Pl. 21, fig. 2b), consisting of narrow, elongated pustules.

Material examined – Anda1, RGM 517 567 (many), RGM 539 801 (1; Pl. 21, fig. 2), RGM 539 802 (1; Pl. 21, fig. 3); Anda2, RGM 517 568 (many), RGM 517 569 (1; Pl. 2, fig. 2), RGM 517 570 (1; Pl. 2, fig. 3), RGM 539 800 (1; Pl. 21, fig. 1); Anda3, RGM 517 571 (many), RGM 517 572 (1; Pl. 2, fig. 1); Anda4, RGM 517 573 (many); Anda6, RGM 517 574 (45); AndaClif1, RGM 429 281 (4, many juveniles), RGM 429 282 (11 fragments); AndaClif3, RGM 429 315 (6, many juveniles); RGM 429 316 (19 fragments); AndaDeVos,

RGM 517 575 (many); Roxas, RGM 517 576 (30, 3 fragments); Tiep1, RGM 517 577 (8), Tiep2, RGM 517 578 (many); Tiep3, RGM 517 579 (many), Tiep4, RGM 517 580 (45); Tiep5, RGM 517 581 (many).

Discussion – Juvenile specimens of this species in which the apertural structures are not yet developed demonstrate a certain resemblance with *Striolimacina andaensis* (see below) of similar size. Apart from the different micro-ornament present in the latter (only seen at higher magnification), discriminating between these two species is also possible. In *S. andaensis* the apical plane is slightly elevated, whereas it is concave in *Heliconoides inflata*, because the whorls of that species attach slightly higher onto the preceding whorl. Also in *H. inflata*, the whorls increase more rapidly in diameter.

***Heliconoides sondaari* sp. nov.**

Pl. 1, fig. 7; Pl. 21, figs. 4-7; Pl. 22, fig. 1.

Holotype – RGM 517 586 (Pl. 1, fig. 7).

Type locality – Anda3, Cabarruyan Island (Pangasinan, Philippines), coastal cliff section at co-ordinates c. N 16° 17.413' E 119° 56.197', map-sheet 6975-I, Bolinao (Fig. 1).

Stratum typicum – Greyish-brown marlstone, in interbedded sandstone, siltstone and claystone, below Bolinao Limestone, Pliocene.

Derivatio nominis – This species is named after Dr Paul Yves Sondaar (1934 - 2003), who joined the 2001 Pangasinan collecting trip, and who was a so much appreciated colleague and friend. He deceased before having enjoyed life sufficiently.

Paratypes – Anda1, RGM 517 584 (62); Anda2, RGM 517 585 (53); Anda3, RGM 517 587 (many), RGM 539 803 (1; Pl. 21, fig. 4), RGM 539 804 (1; Pl. 21, fig. 5), RGM 539 805 (1; Pl. 21, fig. 6); Anda4, RGM 517 588 (many), RGM 539 806 (1; Pl. 21, fig. 7), RGM 539 807 (1; Pl. 22, fig. 1); Anda6, RGM 517 589 (22); AndaClif1, RGM 429 283 (15 juveniles); AndaClif3, RGM 429 317 (24 juveniles); AndaDeVos, RGM 517 590 (20); Roxas, RGM 517 591 (8); Tiep1, RGM 517 592 (10); Tiep2, RGM 517 593 (12); Tiep3, RGM 517 594 (19); Tiep4, RGM 517 595 (8); Tiep 5, RGM 517 596 (c. 40).

Diagnosis – *Heliconoides* with a low conical shell, apical angle approximately 110° and an apertural reinforcement in the form of a slightly accentuated ridge just behind the apertural margin (Pl. 1, fig. 7a-b).

Description – Small sinistral shell with a width of approximately 1 mm and 3¼ to 3½ slightly convex whorls, together forming a regular cone (H/W ratio = 85) with an apical angle of roughly 110°. Tangents along the whorls are straight or very slightly convex. The whorls increase gradually in diameter, the height of the body whorl equals seven/eighths of the total shell height. Just in front of the apertural margin a reinforcement is present in the form of a weakly developed vertical thickening (Pl. 1, fig. 7a, b; poorly seen in Pl. 21, fig. 4). The aperture has a height of 60 % of the total shell height and is

gradually rounded, but angular at the place where lower margin and columella join. The columella is straight, uncommonly with a slight notch at half height and slightly curved backward. The base of the shell is gradually rounded and has a narrow umbilicus. The surface of all whorls is smooth, apart from very faint growth lines.

Discussion – During analysis of the first available samples (AndaClif1 and 3), which yielded only juvenile specimens, this species was considered to be identical with the Recent *Limacina lesueuri* (d'Orbigny, 1836), with which these immature shells agree almost perfectly in shape (see van der Spoel, 1967, p. 52, fig. 20), although the absence of spiral lines (that are typical for *L. lesueuri*, nicely illustrated in Kunz, 1996, pl. 3, fig. 1) on the base of the shells was noted. Adult specimens retrieved from the later collected samples differ, however, by the presence of the apertural reinforcement, which makes them belong to the genus *Heliconoides* (compare Janssen, 2003). The Australian Miocene species *Heliconoides lunata* (Janssen, 1990, p. 18, pl. 2, figs. 8-10) is similar in shape, but has a differently orientated apertural margin and an internal reinforcing apertural ridge.

Also juvenile, relatively low-spired *Limacina valvatina* (Reuss, 1867) looks like *H. sondaari*, but adult specimens of *L. valvatina* reach larger size and lack a reinforced apertural margin. *Limacina valvatina* is not known to occur younger than Late Miocene.

In the present material most of the adult specimens are a bit crushed, as a result of which the apices are commonly somewhat depressed, which makes the shells look relatively wider. An equally undescribed, related species from Early Pliocene claystones in southern France (Le Puget-sur-Argens) and several localities in northern Italy resembles *H. sondaari*, but is higher than wide and the pre-apertural reinforcement is unmistakably more flexuous.

Genus *Limacina* Bosc, 1817

Type species – *Limacina helicina* (Phipps, 1774) (Recent).

Limacina bulimoides (d'Orbigny, 1836)

Pl. 1, figs. 8, 9; Pl. 22, figs. 2, 3.

- * 1836 *Atlanta bulimoides*, d'Orbigny, p. 179, pl. 24, figs. 36-38.
- . 1967 *Limacina* (*Munthea*) *bulimoides* (Orbigny): van der Spoel, p. 53, fig. 21 (with extensive synonymy of mainly Recent occurrences).
- . 1983 *Limacina bulimoides* (d'Orbigny): Shibata & Ujihara, p. 158, pl. 43, figs. 3, 4.
- . 1983 *Limacina trochiformis* (d'Orbigny): Shibata & Ujihara, p. 158, pl. 43, fig. 2 (*non* d'Orbigny).
- . 1986 *Limacina bulimoides* (d'Orbigny): Shibata, p. 124.
- . (1996) *Limacina bulimoides* (d'Orbigny): Kunz, p. 64, pl. 2.
- v. 1998 *Limacina bulimoides* (d'Orbigny): Janssen, p. 99, pl. 1, figs. 6-8.

Description – See van der Spoel (1967).

Material examined – Anda1, RGM 517 597 (many), RGM 517 598 (1; Pl. 1, fig. 8), RGM 517 599 (1; Pl. 1, fig. 9); Anda2, RGM 517 600 (many); Anda3, RGM 517 601 (many); Anda4, RGM 517 602 (many), RGM 539 808 (1; Pl. 22, fig. 2), RGM 539 809 (1; Pl. 22, fig. 3); Anda6, RGM 517 603 (22); AndaClif1, RGM 429 280 (c. 40 juveniles); AndaClif3,

RGM 429 314 (20 juveniles); AndaDeVos, RGM 517 604 (10); Roxas, RGM 517 605 (20); Tiep1, RGM 517 606 (19); Tiep2, RGM 517 607 (4, many fragments); Tiep3, RGM 517 608 (c. 25); Tiep4, RGM 517 609 (9); Tiep5, RGM 517 610 (many).

Discussion – This is a further record of Pliocene occurrences of this species. Janssen (1998) mentioned nine specimens from the Piacenzian of the Bowden shell beds (Jamaica), and referred to specimens from the Pliocene of southern France and Italy. In the present samples, the first records of Pacific Pliocene specimens, *L. bulimoides* is a common species, but most shells are damaged or deformed, commonly with the apices pressed down. From Japan this species has only been recorded from the Pleistocene (Blow zone N 23) (Shibata & Ujihara, 1983; Shibata, 1986). The specimen illustrated by Shibata & Ujihara (1983) as *Limacina trochiformis* is a juvenile shell of *L. bulimoides*.

Kunz (1996) described and beautifully illustrated three types of micro-ornament for protoconch-1, protoconch-2 and teleoconch of Recent *L. bulimoides* from the Gulf of Aden. The same ornament is present in the Pangasinan specimens (Pl. 22, figs. 2b, 3b).

Genus *Striolimacina* Janssen, 1999a

Type species – *Striolimacina imitans* (Gabb, 1873) (Miocene-Pliocene).

Remarks – Janssen (1999a) designated a ‘neolectotype’ for this genus, without realising that the ICZN code does not recognise this kind of type. Since the original lectotype, designated by Pilsbry (1922, fig. 1) is lost, it seems best to consider the ‘neolectotype’ just the lectotype.

***Striolimacina andaensis* sp. nov.**

Pl. 2, figs. 4, 5; Pl. 22, figs. 4, 5.

Holotype – RGM 517 615 (Pl. 2, fig. 4).

Type locality – Anda4, Cabarruyan Island (Pangasinan, Philippines), coastal cliff section at co-ordinates c. N 16° 17.413' E 119° 56.197', map-sheet 6975-I, Bolinao (Fig. 1).

Stratum typicum – Greyish-brown marlstone, in interbedded sandstone, siltstone and claystone, below Bolinao Limestone, Pliocene.

Derivatio nominis – The species is named after the type locality.

Paratypes – Anda1, RGM 517 611 (36); Anda2, RGM 517 612 (20); Anda3, RGM 517 613 (many); Anda4, RGM 517 614 (many), RGM 517 616 (1; Pl. 2, fig. 5), RGM 539 812 (1; Pl. 22, fig. 4), RGM 539 813 (1; Pl. 22, fig. 5); Anda6, RGM 517 617 (3); AndaClif1, RGM 517 618 (1); Tiep2, RGM 517 619 (25); Tiep3, RGM 517 620 (48); Tiep4, RGM 517 621 (2); Tiep5, RGM 517 622 (many).

Diagnosis – *Striolimacina* differing from the type species by a moderately elevated spire, which makes all whorls visible in frontal view.

Description – Sinistral shell, approximately 1.4 times wider than tall, with $2\frac{1}{2}$ - $2\frac{3}{4}$ rather convex whorls that attach just above the periphery of the penultimate whorl and together form a depressed spire with an apical angle of approximately 140° . The whorls are all visible in a frontal view. The base of the shell is gradually rounded and has a relatively narrow umbilicus, occupying one ninth of the shell diameter. The aperture is rounded, with a straight columellar side. The transition from the lower apertural margin into the columellar side is angular. In the largest available specimens the apertural margin is slightly thickened internally and/or externally, sometimes only visible from outside by a more opaque zone along the margin. The surface of the shell at first glance is smooth, apart from very faint growth lines, but at a magnification of $50\times$ a micro-ornament is visible, as described for the type species of *Striolimacina imitans* (Gabb, 1873). This ornament exists of superficially incised lines, lengthwise on the periphery, and diverging backwards above and below the periphery, disappearing close to the suture. In the present species this micro-ornament is slightly more weakly developed than in the type species (Pl. 22, figs. 4b, 5b).

Discussion – *Striolimacina andaensis* differs clearly and constantly from the Caribbean Mio-Pliocene type species *S. imitans* by its elevated spire. Unfortunately, the available specimens are poorly preserved, most of them being crushed and/or showing fissures. Only very few specimens are sufficiently adult to demonstrate the apertural reinforcements and only externally, as all shells are filled with matrix. Differentiation from the accompanying *Heliconoides inflata* is easy, even for juvenile specimens, as in the latter species the upper apertural margin always reaches higher than the penultimate whorl and furthermore by its more rapidly expanding whorl diameter, in specimens of the same dimensions *S. andaensis* always has more whorls (compare Pl. 2, figs. 3a and 4a). This is the first record of *Striolimacina* from the Pacific realm.

Incerti familiae
***Limacinidae* sp.?**

Pl. 2, fig. 6.

Description – Just a few specimens of a very small sinistral gastropod are available, with a shell width (largest specimen) of only 0.85 mm. The shell is approximately 1.4 times wider than high and has $2\frac{1}{4}$ whorls, together forming an almost flat apical plane, with the first whorl just visible in frontal view. The aperture is large, circular and occupies the entire shell height, and even reaches a bit higher than the penultimate whorl, but is damaged in all specimens. The body whorl is gradually rounded, the umbilicus has a diameter of approximately one seventh of the shell width. At the beginning of the body whorl, five distinct crests radiate from the umbilicus onto the base of the shell, but do not reach the periphery.

Material examined – Anda1, RGM 517 623 (1; Pl. 2, fig. 6); Anda2, RGM 517 624 (2); Anda3, RGM 517 625 (1); Anda4, RGM 517 626 (1); AndaClif1, RGM 517 627 (4); Anda-Clif3, RGM 517 628 (1).

Discussion – In general shell form these specimens resemble juvenile *Heliconoides inflata*, in which species the aperture also protrudes above the penultimate whorl. In the

present specimens the aperture, however, is larger and more circular. The presence of the basal crests is very peculiar, a feature unknown to date in Limacnidae, slightly resembling the relatively coarser crests seen on the base of (dextral) *Carinaria* protoconchs (Pl. 20, fig. 5). As apparently not a single fully grown specimen was found, it cannot be excluded that these specimens represent protoconchs of some benthic species (Pyramidellidae?), although their shape and very thin shell wall strongly suggest Limacnidae. But also the nudibranchs *Elysia* Risso, 1818, *Aplysia* (K. Bandel, in litt.) and *Facelina* have sinistral larval shells; the latter two were illustrated by Rudman (1999, 2000). Those of *Aplysia* have a diameter of 0.35 mm and it is not known if they have similar crests on their base.

Several specimens were found to be identical with the immature and defective shell from Bowden, Jamaica, illustrated by Janssen (1998, p. 99, pl. 1, fig. 13a-b) as '*Limacina?* sp. 2.' From the present samples, a number of similar, but larger and more complete specimens were isolated, showing that after the second whorl a strong carina develops along the edge of the umbilicus and ultimately a narrow, thickened apertural margin is formed. By these features it is clear that these are no pteropods. Dr Rüdiger Bieler (Chicago, in litt., December 2005) acknowledged the idea that these are larval shells of the benthic gastropod family Architectonicidae. Two specimens of these protoconchs are illustrated here (Pl. 23, figs. 1, 2; RGM 539 810-539 811). Almost identical specimens were illustrated by Richter (1976a, fig. 10) as '*Agadina?* sp. and by Bandel *et al.* (1997, p. 193, fig. 24F-H) as Architectonicidae.

Superfamily Cavolinioidea Gray, 1850

Family Creseidae Curry, 1982

Genus *Creseis* Rang, 1828

Type species – *Creseis virgula* (Rang, 1828) (Recent).

Creseis chierchiaie (Boas, 1886) forma *constricta* Chen & Bé, 1964

Pl. 2, figs. 7, 8; Pl. 23, figs. 3-6.

Synonymy – Selected synonyms (mainly restricted to papers in which the species is illustrated):

- * 1886 *Cleodora Chierchiaie* Boas n. sp., pp. 62, 202, figs. 39ter, 43bis-ter.
- . 1888 *Clio (Creseis) chierchiaie* (Boas): Pelseneer, p. 53.
- 1889 *Creseis (Boasia) chierchiaie* Boas: Dall, p. 80.
- 1905 *Creseis Chierchiaie* Boas: Meisenheimer, p. 17, map 3.
- 1913 *Creseis chierchiaie* (Boas): Tesch, p. 25, fig. 19A-C.
- ? 1915 *Creseis virgula* Rang: Vayssière, pl. 11, fig. 238 (*non* Rang?).
- 1934 *Creseis (Boasia) chierchia (sic)*: Johnson, p. 151.
- . 1951 *Creseis chierchiaie* (Boas): Tokioka, p. 184, fig. 10.
- non* 1958 *Creseis chierchiaie* Boas: Menzies, p. 386, fig. 2C-D [not D-E; *non* Boas = 'beaked larva' *sensu* van der Spoel & Newman, 1990].
- (1960) *Creseis chierchiaie* (Boas): McGowan, p. 161.
- . 1963 *Creseis chierchiaie* (Boas): Frontier, p. 229, 1 fig.
- . 1964 *Creseis virgula constricta* Chen & Bé n. subsp., p. 194, figs. 3d, 4d.
- . 1965 *Creseis chierchiaie* (Boas): Frontier, p. 14, pl. 4, figs. 9-11.

- . 1967 "*Creseis chierchiaie* (Boas)": van der Spoel, p. 62, fig. 42.
- . 1967 *Creseis virgula constricta* Chen & Bé: van der Spoel, p. 61 [incorrectly considered a synonym of *Creseis virgula* (Rang, 1828) forma *virgula* (Rang, 1828)].
- . 1967 *Hyalocylis striata* (Rang): van der Spoel, p. 64, fig. 42 (*pars*, non Rang, non figs. A, B).
- . 1971 *Creseis virgula constricta*: Herman & Rosenberg, pl. 1, fig. 6.
- . 1973 *Creseis chierchiaie*: Richter, p. 269, fig. 3.
- non 1973 *Creseis virgula constricta* Chen & Bé: Jung, p. 753, pl. 2, fig. 10 (non Chen & Bé, 1964 = *Creseis virgula*).
- . 1974 *Creseis bulgia* Sakthivel n. sp., p. 619, figs. 1, 2.
- . (1975) *Creseis chierchiaie* (Boas): Rampal, p. 12ff, fig. 2(16).
- . 1976 *Creseis chierchiaie* Boas: Richter, p. 145ff, figs. 1-3.
- . 1976 (*Creseis*) *virgula constricta* Chen & Bé: Richter, p. 145ff, figs. 1-3.
- 1976a *Creseis chierchiaie* (Boas): Van der Spoel, p. 111.
- . 1977 *Creseis virgula* (Rang, 1828) *constricta* (Chen and Bé) (*sic*): Bé & Gilmer, p. 49ff, pl. 5, fig. 12a, b.
- . 1979 *Creseis chierchiaie* (Boas): Richter, p. 15, pl. 1, figs. 8, 11.
- . 1980 *Creseis bulgia*: Rottmann, p. 73ff, fig. 4A, C.
- . 1980 *Creseis chierchiaie*: Rottmann, p. 73ff, fig. 4B, D.
- . 1982 *Creseis chierchiaie*: Almogi-Labin, p. 60, pl. 2, figs. 4, 5.
- . 1983 *Creseis chierchiaie* (Boas): Shibata & Ujihara, p. 160, pl. 44, fig. 3.
- non 1983 *Creseis virgula constricta* Chen & Bé: Shibata & Ujihara, p. 160, pl. 4, fig. 2a-b (= *Creseis virgula*).
- . 1985 *Creseis chierchiaie*: Ivanova, p. 352ff, pl. 3, figs. 3, 4.
- . 1985 *Creseis acicula* forma *clava* (Rang): Ivanova, pl. 3, fig. 5 (non Rang).
- v. 1990 *Creseis* cf. *chierchiaie* (Boas): Janssen, p. 26, pl. 5, figs. 1-4, pl. 12, fig. 1.
- v. 1990 *Creseis chierchiaie* (Boas): Janssen, p. 28, pl. 5, fig. 5.
- v. 1990 *Creseis chierchiaie* (Boas) f. *constricta* Chen & Bé: Janssen, p. 28, pl. 5, fig. 6.
- . 1990 *Creseis chierchiaie* (Boas): van der Spoel & Newman, p. 206, fig. 4a, b.
- . (1996) *Creseis chierchiaie* (Boas): Kunz, p. 80, pl. 7.
- ? 1990 *Creseis acicula* (Rang) forma *clava* (Rang): van der Spoel & Dadon, p. 682, fig. 6.45 (non Rang?).
- . 1999 *Creseis chierchiaie* (Boas): van der Spoel & Dadon, p. 682, fig. 6.46.
- . 1999 *Creseis virgula* (Rang) forma *constricta* Chen and Bé: van der Spoel & Dadon, p. 682, fig. 6.48.
- . 1999 *Hyalocylis striata* (Rang): van der Spoel & Dadon, p. 682, fig. 6.50c (non Rang, only the 'larval shell' of the illustrated specimen, indicated as 'specimen with caudal section attached').
- . 2002 *Creseis chierchiaie* (Boas): Rampal, p. 236, figs. 10H-R, 11.).

Description – Shell very small ($H < 2$ mm), conical, straight or slightly curved, especially in its lower part, and with a circular transverse section. The larval shell is approximately 0.5 mm high (0.42 - 0.58 mm), it has a rounded tip and a tubiform initial part, followed by a swelling, separated from the teleoconch by a clear, gradual constriction. The surface of the adult shell is smooth, apart from vague growth lines, that close to the aperture in some specimens are slightly stronger developed.

Material examined – (p = specimens preserving protoconch) – Anda1, RGM 517 629 (3), RGM 539 814 (1p; Pl. 23, fig. 3); Anda2, RGM 517 630 (5, 3p), RGM 539 816 (1p; Pl. 23, fig. 5), RGM 539 817 (1p; Pl. 23, fig. 6); Anda3, RGM 517 631 (19); Anda4, RGM 517 632 (49), RGM 517 633 (1; Pl. 2, fig. 7), RGM 517 634 (1; Pl. 2, fig. 8), RGM 517 635 (1p), RGM 539 815 (1; Pl. 23, fig. 5); AndaClif1, RGM 429 285 (6p); Roxas, RGM 517 636 (1p); Tiep2, RGM 517 637 (2); Tiep3, RGM 517 638 (10); Tiep4, RGM 517 639 (6); Tiep5, RGM 517 640 (6).

Measurements – The few available specimens retaining their protoconch were measured (Table 13) in the same way as in Janssen (1990, table, p. 28; in the heading of that table it should read of ‘diameter of inflated part,’ instead of ‘length of inflated part’) for specimens from Australia. The mean values found for the Pangasinan specimens agree much better with Recent shells than with the Miocene Australian ones (Janssen, 1990). The diversity, however, is larger, especially so for protoconch height. Considering the restricted number of Recent and Pliocene specimens measured these differences may have no significance at all. The Australian specimens, on the other hand, on the average are distinctly larger.

Discussion – Ever since its introduction by Boas (1886), the taxon *Creseis chierchiae* was accepted by all authors as a species distinctly different from other Recent *Creseis* species and easily recognised by its transverse annulations. The only misunderstanding with regard to this species was van der Spoel’s (1967, repeated 1976a) idea that this species was nothing else than the larval shell of *Hyalocylis striata* (Rang, 1828). This was rejected by Richter (1976b), who made clear that *C. chierchiae* in reality is an independent species. This was finally admitted by van der Spoel & Newman (1990, p. 206), who were able then to study a real larval shell of *H. striata*. Curiously enough, however, van der Spoel & Dadon (1999, fig. 6.50c) still illustrated *H. striata* with *C. chierchiae* as its larval shell. A further discussion on the larval shell of *Hyalocylis striata* is given in Janssen (2007, p. 154).

Table 13. Protoconch measurements of *Creseis chierchiae* (Boas, 1886) forma *constricta* Chen & Bé, 1964.

locality	diameter of protoconch tip	diameter of inflated part	height of protoconch
Anda1	0.08	0.16	0.42
Anda2	0.06	0.14	0.45
	0.06	0.15	0.44
	0.07	0.13	0.54
	0.07	0.14	0.42
Anda4	0.07	0.14	0.42
AndaClif1	0.07	0.13	0.46
	0.06	0.12	0.48
	0.06	0.13	0.58
	0.07	0.14	0.48
	0.06	0.14	0.44
Roxas	0.06	0.14	0.47
spreading	0.06-0.08	0.12-0.16	0.42-0.58
mean value (n = 12)	0.066	0.138	0.466
Data from Janssen (1990):			
Recent specimens (off Salayer, Flores Sea, Indonesia)			
spreading	0.06	0.14-0.15	0.40-0.46
mean value	0.06	0.144	0.428
Australian Miocene specimens (Janssen, 1990)			
spreading	0.08-0.09	0.16-0.18	0.48-0.54
mean value	0.083	0.168	0.516

More problems, however, gave '*Creseis virgula constricta*', described by Chen & Bé (1964) from the western North Atlantic. Frontier (1965, p. 13) found numerous intermediate forms between *C. chierchiaie* and *C. constricta* at Nosy Bé (Madagascar) in which the transverse annulations are reduced or lacking, leading to the inevitable conclusion that *C. constricta* is nothing else than a forma of *C. chierchiaie*. This observation was acknowledged in 'Meteor' material (Indian Ocean) by Richter (1976b). Van der Spoel & Dadon (1999), however, still considered *C. constricta* to be a forma of *C. virgula*, in spite of obvious differences in the protoconch morphologies.

The name *constricta* is applied to forms in which the annulations are absent. In the present material only specimens of this latter form are found. Typical *Creseis chierchiaie* has not yet been recorded as a Cainozoic fossil, so most probably *constricta* is the ancestral form.

Creseis clava (Rang, 1828)

Fig. 7; Pl. 2, figs. 9, 10; Pl. 23, figs. 7, 8.

Synonymy – Synonyms are predominantly restricted to references of fossil specimens in which the species is illustrated. For further synonymy on mainly Recent occurrences, see van der Spoel (1967) sub *Creseis acicula* f. *acicula* and *C. acicula* f. *clava*. Many references of *C. clava* in reality concern *Creseis conica* Eschscholtz, 1829 (see discussion), and have to be checked individually on the specimens.

- * 1828 *C[leodora (Creseis)] clava* Rang N., p. 317, pl. 17, fig. 5.
- . 1828 *C[leodora (Creseis)] acicula* Rang N., p. 318, pl. 17, fig. 6.
- . 1912 *Clio (Creseis) acicula* (Rang): Yamakawa & Ishikawa, p. 2, pl. 1, fig. 2 (*non* fig. 1a-b = *Heliconoides inflata*).
- . 1934 *Creseis acicula* Rang: Collins, p. 207, pl. 9, figs. 6, 7; pl. 13, figs. 7, 8.
- . 1970 *Creseis acicula* (Rang): Colantoni *et al.*, p. 179, pl. 24, fig. 11.
- . 1973 *Creseis acicula* (Rang): Jung, p. 753ff., pl. 2, fig. 9.
- . 1967 *Creseis acicula* (Rang) forma *acicula* (Rang): van der Spoel, p. 58, figs. 22, 23, 26, 27.
- ? 1967 *Creseis acicula* (Rang) forma *clava* (Rang): van der Spoel, p. 59, fig. 28 (partim?).
- . 1976b *Creseis acicula* forma *acicula* Rang: van der Spoel, p. 189 (with lectotype designation).
- . 1976b *Creseis acicula* forma *clava* Rang: van der Spoel, p. 189 (with lectotype designation).
- . 1977 *Creseis acicula* (Rang): Almogi-Labin & Reiss, p. 10, pl. 4, figs. 1-3.
- . 1978 *Creseis acicula* Rang: Buccheri, p. 128, pl. 2, fig. 5.
- . 1979 *Creseis acicula* (Rang): Richter, p. 14, pl. 1, fig. 4.
- . 1979 *Creseis acicula acicula* Rang: Shibata, p. 117ff, pl. 20, figs. 19-21.
- . 1980 *Creseis* cfr. *acicula* Rang: Shibata, p. 64, pl. 3, fig. 1.
- . 1981 *Creseis acicula* Rang: Buccheri & Torelli, pp. 78, 79, 81, 83, figs. 2, 3.
- . 1981 *Creseis* (cfr.) *acicula* Rang: Shibata & Ishigaki, p. 57, figs. 5, 6.
- . 1982 *Creseis acicula* Rang: Grecchi, p. 718, pl. 54, figs. 7, 8.
- . 1983 *Creseis acicula acicula* Rang: Shibata & Ujihara, p. 153, 159, pl. 44, fig. 1a, b.
- . 1984 *Creseis acicula* forma *acicula* Rang: Shibata, p. 78, pl. 23, figs. 9, 10.
- . 1984 *Creseis acicula* Rang: Grecchi, p. 15, pl. 1, fig. 14.
- . 1988 *Creseis acicula* (Rang): Grecchi & Bertolotti, p. 104, pl. 1, fig. 7.
- ? 1990 *Creseis acicula* f. *acicula* (Rang): Ujihara *et al.*, p. 312, pl. 1, fig. 1.
- . 1996 *Creseis acicula* forma *acicula* (Rang): Ujihara, p. 774, fig. 3.5.
- v. 1999a *Creseis acicula* (Rang): Janssen, p. 15, pl. 3, figs. 1, 2.
- . 2002 *Creseis acicula* (Rang): Rampal, p. 231, figs. 9A-J.

Description – See van der Spoel (1967, p. 58, figs. 22, 23, 26, 27 [as *Creseis (Creseis) acicula* forma *acicula*]).

Material examined – Anda1, RGM 517 641 (many); Anda2, RGM 517 642 (many), RGM 517 643 (1; Pl. 2, fig. 9), RGM 517 644 (1; Pl. 2, fig. 10), RGM 517 645 (1); Anda3, RGM 517 646 (many), RGM 539 818 (1; Pl. 23, fig. 7), RGM 539 819 (1; Pl. 23, fig. 8); Anda4, RGM 517 647 (many); Anda6, RGM 517 648 (10); AndaClif1, RGM 429 284 (21); AndaClif3, RGM 429 318 (8); Roxas, RGM 517 649 (35); Tiep2, RGM 517 650 (8); Tiep3, RGM 517,651 (35); Tiep4, RGM 517 652 (15); Tiep5, RGM 517 653 (40).

Discussion – For this species the name *Creseis acicula* is generally used in modern literature, with which name, however, the present author does not agree, as will be clear from the discussion below. For a long time two formae or subspecies used to be distinguished in Recent '*Creseis acicula*', viz. *C. acicula* f. *acicula* Rang, 1828, and f. *clava* Rang, 1828 (or *C. acicula acicula* and *C. acicula clava*). Considering the fact that their distribution patterns are completely overlapping (van der Spoel, 1967, fig. 343), a subspecific rank is not appropriate. Many authors before van der Spoel (1967) related *C. clava* also to the species *C. conica* Eschscholtz, 1829, or *C. virgula* (Rang, 1828), but these differ clearly by the shape of their larval shells.

Comparing the descriptions and illustrations in Rang (1828, pl. 17, figs. 5, 6), it is obvious that both taxa resemble each other intimately, with hardly or not differing apical angles (Rang's statement in the description of *C. acicula*: 'plus grêle à proportion que

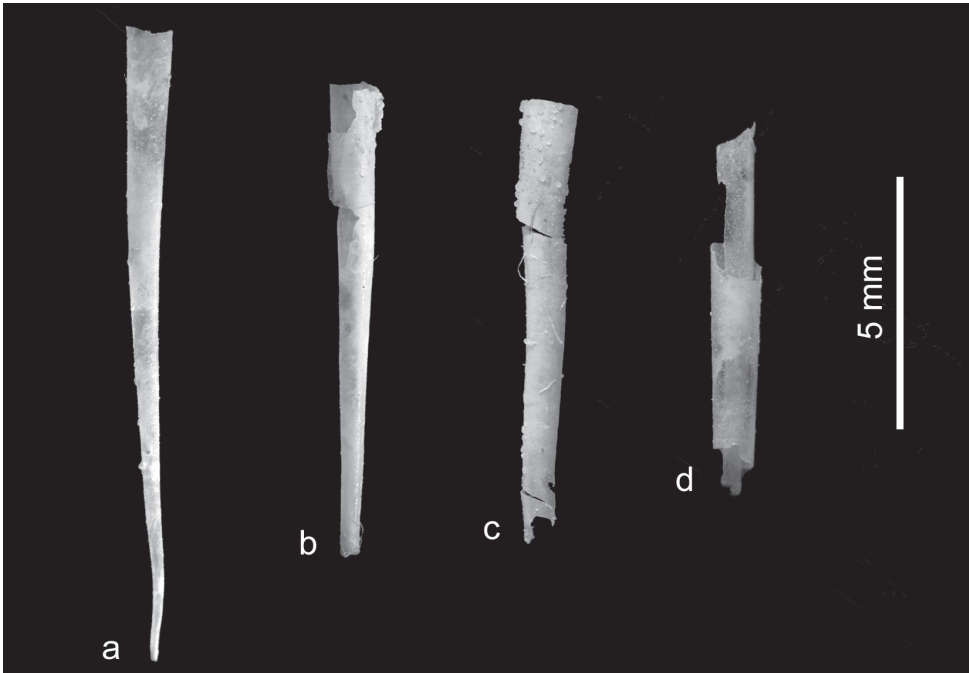

Fig. 7. *Creseis clava* (Rang, 1828). (a) Lectotype of *Creseis acicula*. (b) Lectotype and (c-d) paralectotypes of *C. clava*. Photographs by courtesy of Mr Pierre Lozouet (MNHN).

la précédente' [= *C. clava*] is barely visible from his illustrations!). The drawings given by this author show that in *C. acicula* the shell is a bit irregular, whereas *C. clava* is completely straight. Indeed, Rang himself already stated (1828, p. 318, sub *C. acicula*) 'Je ne pense pas que cette espèce soit un jeune individu de la précédente (= *C. clava*), elle en serait plutôt une variété.' Measurements given by Rang are '0,022' for *C. clava* and '0,012' for *C. acicula*.

D'Orbigny (1836, p. 123, pl. 8, figs. 29-31; as *Hyalaea aciculata* (*sic*) Rang) was unable to separate Rang's two taxa, but considered '*aciculata*' a valid species and *C. clava* its synonym. The change of the epitheton '*acicula*' to '*aciculata*' apparently is a lapsus, as '*aciculata*' is also cited as a synonym. Cantraine (1841, p. 32, pl. 1, figs. 12, 13) more correctly took *C. clava* as a valid species and *C. acicula* as a variety (distinguished by the irregularity of the shell in *C. acicula*).

Souleyet (1852b, p. 56), describing '*Cleodora acicula*', again treated *C. clava* as a synonym, stating: 'M. Rang a établi, sur l'une de ces variétés, une espèce qu'il a désignée sous le nom de *C. clava*, et qui différerait de la *C. acicula* par ses proportions plus courtes et moins grêles.' In this statement two erroneous conclusions occur. First, Rang did not believe *C. clava* to be a variety of *C. acicula*, but rather vice versa considered *C. acicula* to be 'plutôt une variété' (of *C. clava*)! Furthermore, the statement that *C. clava* is 'plus courte' than *C. acicula* (see dimensions given by Rang) is incorrect. These conclusions (maybe partly induced by d'Orbigny, 1836) apparently led to the situation that all later authors accepted *C. acicula* as a valid species and *C. clava* as a synonym or a smaller and less slender 'form', at the most.

Boas (1886, p. 59, as *Cleodora acicula*) followed d'Orbigny and Souleyet in treating *C. clava* as a synonym of *C. acicula*, but stressed the difficulty of separating *C. acicula* from, in particular, Indo-Pacific specimens of *C. virgula* Rang, 1828. Boas (1886, pl. 6, figs. p-u), however, included forms in *C. acicula* distinctly less slender than the ones illustrated by Rang.

Also, Penseiner (1888, p. 53) accepted *C. acicula* as a valid species, with *C. clava* as its synonym. Furthermore, this author gave anatomical differences distinguishing *C. acicula* from related creseids. The same is true for Vayssière (1915, p. 98, pl. 1, fig. 29, pl. 11, fig. 237).

Tesch (1904, p. 23) was obviously guided by the 'plus grêle' of Rang and considered *Creseis clava* a synonym of *C. virgula*. But Tesch (1913, p. 25) included *C. clava* as a subspecies in *C. acicula*, giving priority to the latter. As main differences for *C. clava* he gave 'Schale gestreckt, aber kurz kegelförmig' with a shell height of 6 mm (33 mm for *C. acicula*). In his figure 18, Tesch illustrated five specimens as *C. acicula acicula*. Of the two protoconchs illustrated (fig. 18D-E), figure D ('Embryonalschale eines kürzeren ... Exemplares') clearly does not belong to the *C. clava/acicula*-complex, but rather to *C. conica*.

The characteristics given by Tesch (1913) were maintained in van der Spoel (1967, p. 58), but here the two names are treated as formae, *C. acicula* f. *acicula* and *C. acicula* f. *clava*. Richter (1979) treated *Creseis acicula* and *C. clava* as separate species. The illustrations of the latter (Richter, 1979, pl. 1, figs. 6, 7, 10), however, clearly demonstrate a mixing up again with *C. conica*, induced by earlier authors.

Then, Rampal (1985, p. 259), discussing the various morphologies of extant *Creseis* species, wrote 'to the point' about *Creseis acicula/clava*: 'Il est donc vraisemblable qu'on ait attribué à *clava* des formes droites de *conica* ...' and also 'En raison du polymorphisme de *C. acicula* don't *clava*, si elle existe, est vraisemblablement très proche (stade im-

mature, forme ou sous-espèce) ...' From these statements it is clear that Rampal did not accept a less elongate shape of *C. clava* as a characteristic, but she still accepted *C. acicula* as the valid name.

The opinion of two formae in *C. acicula* was retained by van der Spoel & Dadon (1999, p. 682, figs. 6.44, 6.45). The illustration given by these latter authors for *C. acicula* f. *clava* (fig. 6.45), however, depicts a shell with a much wider apical angle and a different shape of the protoconch, which has not the slightest resemblance with what Rang originally illustrated and represents *Creseis chierchiae* f. *constricta* (see above).

Finally, Rampal (2002, p. 233) stated in her discussion of *C. clava* 'Dès sa découverte, l'auteur lui-même hésite à en faire une variété plus courte plutôt qu'un jeune *Creseis acicula*.' As stated above Rang considered (small) *C. acicula* 'plutôt une variété' of (larger) *C. clava*. Rampal, furthermore, supposed that if specimens between a shell height of 6-12 mm, with the protoconch and tentacular lobe morphology of *C. acicula*, are sexually mature they should be considered a subspecies, *C. acicula clava*. If specimens of that size are sexually immature they represent juvenile *C. acicula*. But in reality Rampal did not find sexually mature specimens of small size and, therefore, apparently considered *C. acicula* and *C. clava* synonymous, but accepting the first name as valid. For specimens with a conical protoconch and a straight, more widening shell she correctly stated 'il s'agit vraisemblablement de l'espèce suivante *C. conica*.'

In the present paper, *C. clava* and *C. acicula* are considered synonyms, and the name *Creseis clava* is given priority, exactly according to the intention of its original author, and supported by the existing 'page priority' of *C. clava*, in spite of the fact that *C. acicula* nowadays is the generally accepted name. The taxon *C. clava*, however, has been in use permanently, albeit usually erroneous, and cannot be neglected. Here it is restored in its original sense.

Lectotypes of *Creseis acicula* and *C. clava* (designation van der Spoel, 1976b) are housed in MNHN. Mr Pierre Lozouet of that institute was so kind to provide photographs (Fig. 7), showing that there is no difference whatsoever in apical angle, the only difference being the slightly irregular shape of *C. acicula*, which is no reason to maintain separate species.

Creseis clava could be recognised easily in the Pangasinan material, as specimens preserving their protoconch are present in most samples. Therefore, larger fragments, showing only few specific characteristics, can also be identified with some certainty. They can be distinguished from a similarly shaped, co-occurring scaphopod species by their much thinner shell wall, the non-lustrous surface and hardly or not visible growth lines.

Genus *Hyalocylis* Fol, 1875

Type species – *Hyalocylis striata* (Rang, 1828) (Recent).

Hyalocylis marginata sp. nov.

Pl. 3, figs. 5, 6; Pl. 23, figs. 9-11.

Holotype – RGM 517 654 (Pl. 3, fig. 6).

Type locality – Anda6, Cabarruyan Island (Pangasinan, Philippines), coastal cliff section at co-ordinates c. N 16° 17.413' E 119° 56.197', map-sheet 6975-I, Bolinao (Fig. 1).

Stratum typicum – Greyish-brown marlstone, in interbedded sandstone, siltstone and claystone, below Bolinao Limestone, Pliocene.

Derivatio nominis – From *L. margo* (noun) - margin, *marginata* - ‘with a margin’ (named after the reinforced apertural edge).

Paratypes – Anda6, RGM 517 655 (1; Pl. 3, fig. 5); AndaClif3, RGM 517 656 (1 fragment); Tiep2, RGM 517 657 (1 fragment), RGM 517 658 (19 fragments), RGM 539 826 (1; Pl. 23, fig. 9); Tiep3, RGM 517 659 (1 fragment); Tiep5, RGM 517 660 (6 fragments).

Diagnosis – *Hyalocytilis* species closely resembling the Recent *H. striata* (Rang, 1828), but with a reinforced apertural margin.

Description – The extremely fragile shell has the shape of a conical tube, slightly curved dorso-ventrally in its apical part. The largest specimen reaches a shell height of approximately 7 mm and a width at the aperture of 1.8 mm (holotype), but some specimens are somewhat less slender. Initially, the shell has a circular transverse section, but towards the aperture the dorso-ventral diameter becomes slightly less than the shell width. The shell’s surface is covered with numerous annulations, very fine and regular on the early shell parts, but gradually more spaced and sometimes weaker adaperturally (Pl. 23, fig. 9). The apertural margin is reinforced by a distinct rib, stronger than the last annulation and at some distance from it. A protoconch is absent in all available specimens, but in none of the shells is a closing septum seen. Because of the extreme fragility mainly fragments were found. These are easily recognisable when including the apertural margin with the reinforcement.

Additional material examined – Juvenile specimens and/or fragments not preserving the thickened apertural margin, although most probably belonging to this species, cannot be recognised with certainty, as they might also belong to *Hyalocytilis striata*. These are therefore not considered paratypes: Anda1, RGM 517 661 (3 fragments); Anda2, RGM 517 662 (1); Anda3, RGM 517 663 (1 juvenile); Anda4, RGM 517 664 (3 juveniles, 2 fragments), RGM 517 665 (1), RGM 539 820 (1; Pl. 23, fig. 11), RGM 539 821 (1; Pl. 23, fig. 10); Anda6, RGM 517 666 (1), RGM 517 667 (2 juveniles, 1 fragment); AndaClif1, RGM 429 286 (1 juvenile); AndaClif3, RGM 429 319 (3 juveniles, 8 fragments); AndaDeVos, RGM 517 668 (1 juvenile, 2 fragments), Tiep2, RGM 517 669 (6 juveniles, 17 fragments); Tiep3, RGM 517 670 (7 fragments); Tiep5, RGM 517 671 (3 juveniles, 8 fragments).

Discussion – This new species closely resembles *Hyalocytilis striata* (Rang, 1828), but differs clearly by the presence of the reinforced apertural margin, which is absent in *H. striata*. That species, well-known from the extant fauna, was also recorded from the Early to Middle Pliocene of the Dominican Republic by Janssen (1999, pp. 17, 18, with extensive synonymy), who considered the taxa *Tentaculites cretaceus* Blanckenhorn, 1889, *Hyalocytilis euphratensis* Avnimelech, 1945, and *H. haitensis* Collins, 1934, to be synonyms. In none of these was a reinforced margin observed, but, considering the poor

condition of most material, it cannot be excluded that (part of?) it belongs to the new species. The same goes for records of fossil *H. striata* from Japan (see Ujihara, 1996, p. 776 and references therein). That species is a common constituent of the Takanahe Member, which is here supposed to have more or less the same age as the present Pangasinan material (see the chapter on age assignment).

As stated by Fol (1875, p. 177), who extensively studied pteropod anatomy, the convex side of the curved shell is the ventral side in *Hyalocylis striata*. It is assumed that the same is true for *H. marginata*.

Genus *Styliola* Gray, 1850

Type species – *Styliola subula* (Quoy & Gaimard, 1827) (Recent).

Styliola subula (Quoy & Gaimard, 1827)

Pl. 3, figs. 1-4; Pl. 24, figs. 2, 3.

Description – For extensive synonymy and description, see Janssen (1990, p. 32, pl. 5, figs. 13-19, pl. 6, figs. 1-9; 1999a, p. 18, pl. 3, figs. 7-9 (with neotype designation)).

Material examined – Anda1, RGM 517 672 (many), RGM 517 673 (6 aberrant specimens), RGM 517 674 (1 aberrant specimen, Pl. 3, fig. 2), RGM 517 675 (1 aberrant specimen, Pl. 3, fig. 3), RGM 517 676 (1); Anda2, RGM 517 677 (6), RGM 517 678 (many); Anda3, RGM 517 679 (many), RGM 517 680 (7 aberrant specimens), RGM 539 827 (1 specimen with additional furrow at apertural margin, Pl. 24, fig. 2), RGM 539 829 (1, Pl. 24, fig. 3); Anda4, RGM 517 681 (many), RGM 517 682 (2 aberrant specimens), RGM 517 683 (1 aberrant specimen, Pl. 3, fig. 4); Anda5, RGM 517 684 (1), RGM 517 685 (12 internal moulds); Anda6, RGM 517 686 (4), RGM 517 687 (many), RGM 517 688 (5 aberrant specimens); AndaClif1, RGM 429 287 (many); AndaClif3, RGM 429 320 (many), RGM 429 321 (1 aberrant specimen, Pl. 3, fig. 1); AndaDeVos, RGM 517 689 (many); Roxas, RGM 517 690 (many); Tiep1, RGM 517 691 (many); Tiep2, RGM 517 692 (many); Tiep3, RGM 517 693 (50), Tiep4, RGM 517 694 (25); Tiep5, RGM 517 695 (28).

Discussion – This species is by far the most profuse pteropod in all samples of the Pangasinan material, occurring as thousands of specimens. Several individuals, apparently escaped from predatory attacks or being damaged otherwise, restored their shells after being broken. Commonly, such shells show irregular growth, such as in the form of multiple dorsal furrows. The phenomenon of more than one furrow, however, is also observed in some undamaged shells, usually close to the aperture. Several of these aberrant specimens are illustrated herein (Pl. 3, figs. 1-3; Pl. 24, fig. 2). A peculiar specimen (Pl. 3, fig. 4) has the dorsal furrow, being interrupted after apparent damage of the shell, continuing exactly at the opposite side of the shell's circumference, showing that either the soft parts or the shell must have turned around after the damage through 180°!

Specimens recorded by Noda (1972, p. 481, pl. 57, figs. 1-5) from the Pliocene of Okinawa, Japan, as *Creseis acicula* belong to the present species.

Family Cuvierinidae van der Spoel, 1967
Genus *Cuvierina* Boas, 1886

Type species – *Cuvierina columnella* (Rang, 1827) (Recent).

Subgenus *Urceolarica* Janssen, 2006

(= *Urceolaria* Janssen, 2005, *non* Lamarck, 1801; see Janssen, 2005, p. 49; 2006, p. 67)

Type species – *Cuvierina (Urceolarica) urceolaris* Mörch, 1850 (Recent).

***Cuvierina (Urceolarica) urceolaris* (Mörch, 1850)**

Pl. 3, figs. 7-9; Pl. 24, fig. 1.

- * 1850 *Cuvierina urceolaris* Mörch n., p. 32, pl. 1, fig. 8.
- . 1852a *Cuvierina columnella* Rang: Souleyet, p. 205, pl. 12, fig. 3.
- ? 1852b *Cuvierina columnella* Rang: Souleyet, p. 59, pl. 14, fig. 4.
- . 1886 *Cuvierina columnella* (Rg.): Boas, p. 132 (partim, *non* Rang), pl. 6, fig. 95a-f.
- . 1913 *Cuvierina columnella urceolaris* (Mörch): Tesch, p. 38, fig. 35.
- . 1967 *Cuvierina columnella* (Rang) forma *columnella* (Rang): van der Spoel, p. 79, fig. 74a, b (partim).
- . 1967 *Cuvierina columnella* (Rang) forma *urceolaris* (Mörch): van der Spoel, p. 81, fig. 74c.
- v. 1970 *Cuvierina columnella* (Rang) forma *columnella* (Rang): van der Spoel, p. 120 (partim, *non* Rang).
- v. 1970 *Cuvierina columnella* (Rang) forma *urceolaris* (Mörch): van der Spoel, 1970, p. 120, fig. 21A, B.
- . 1976b *Cuvierina columnella* (Rang) forma *urceolaris* (Mörch): van der Spoel, p. 341, fig. 35d.
- non* 1977 *Cuvierina* cf. *C. columnella* (Rang) forma *urceolaris* (Mörch): Almogi-Labin & Reiss, pp. 12, 32, pl. 4, fig. 11, pl. 5 figs. 1-4 (*non* Mörch = Siphonodentaliidae sp.).
- . 2002 *Cuvierina urceolaris* (Mörch): Rampal, 2002, p. 212, fig. 1Cu.
- v. 2005 *Cuvierina (Urceolaria) urceolaris* (Mörch): Janssen, p. 55, figs. 24-27.

Description – Recent *Cuvierina urceolaris* is characterised by a straight, bottle-shaped shell (H up to 7 mm), with an obvious inflation, situated at 37-48 % (mean 42-43 %) of the shell height (see measurements in Janssen, 2005, fig. 34). The sidelines between the inflation and the aperture are slightly concave in ventral or dorsal view. The aperture is reniform. The surface of the shell has a distinct micro-ornament of longitudinal lines, interfering with growth lines to a very fine reticulation.

Material examined – Anda1, RGM 517 696 (7), RGM 517 697 (20), RGM 517 698 (17 fragments), RGM 517 699 (1; Pl. 3, fig. 7), RGM 517 700 (1 protoconch); Anda2, RGM 517 701 (14), RGM 517 702 (30); Anda3, RGM 517 703 (1), RGM 517 704 (25); Anda4, RGM 517 705 (2), RGM 517 706 (16), RGM 517 707 (1), RGM 517 708 (1; Pl. 3, fig. 9), RGM 517 709 (3 protoconchs), RGM 539 822 (1 protoconch; Pl. 24, fig. 1); Anda6, RGM 517 710 (5), RGM 517 711 (8), RGM 517 712 (1; Pl. 3, fig. 8); AndaClif1, RGM 429 288 (1 protoconch); AndaClif3, RGM 429 322 (9 fragments); AndaDeVos, RGM 517 713 (8 fragments); Roxas, RGM 517 714 (1 fragment); Tiep1, RGM 517 715 (2 internal moulds); Tiep2, RGM 517 716 (1); Tiep5, RGM 517 717 (1 protoconch).

Measurements – Fourteen specimens are sufficiently well preserved to be measured (Table 14). Comparing these figures with data given by Janssen (2005, figs. 29-34) shows

that the Pangasinan specimens are taller and wider than Recent *Cuvierina urceolaris*. Furthermore, the position of strongest inflation is situated slightly higher.

Measurements for *C. inflata* (Bellardi, 1873) (Table 14) are only available for two specimens from Estepona, Spain (Janssen, 2004). These reach larger dimensions and the position of strongest inflation is just above the middle of the shell (Table 15).

Discussion – The Pangasinan material differs from Recent *Cuvierina urceolaris*, as described above, predominantly by larger dimensions, by which at first glance they are reminiscent of *C. inflata* (compare Janssen, 1995, pl. 3, figs. 1-3, and 2004, pl. 2, figs. 9, 10), which likewise is an inflated species with distinct micro-ornament. However, in the present material the sidelines of the shells between maximum inflation and aperture are concave in most specimens, which points rather to *C. urceolaris*, as in *C. inflata* these sidelines are convex or, at best, straight.

Some of the fossil specimens retain parts of their larval shell (Pl. 3, fig. 9). Just a few isolated protoconchs of this species were found, one of which is illustrated (Pl. 24, fig. 1).

Table 14. Measurements of *Cuvierina (Urceolaria) urceolaris* from locality Anda1-6. H = shell height, W = shell width, Wa = width at aperture, Ws = width at septum, Pi = position of strongest inflation above base of septum.

locality	H (mm)	W (mm)	H/W	Wa (mm)	Ws (mm)	Pi (%)
Anda1	6.72	2.82	2.38	2.41	1.66	43
	6.56	2.66	2.47	2.20	1.58	43
	6.64	2.74	2.42	2.32	1.41	50
	6.89	2.66	2.59	2.24	1.58	46
	7.64	2.74	2.79	2.32	1.41	40
	7.22	2.90	2.49	2.24	1.41	48
Anda2	7.05	2.99	2.38	2.41	1.49	46
	6.89	2.74	2.51	2.24	1.49	46
Anda3	6.81	2.74	2.49	2.07	1.24	49
	6.64	2.82	2.35	2.24	1.41	44
Anda4	6.56	2.74	2.39	2.24	1.41	44
	7.05	3.07	2.30	2.41	1.33	48
	6.47	2.90	2.23	2.32	1.66	49
Anda6	8.47	3.49	2.42	2.74	1.66	47
mean (n = 14)	6.97 (6.56-8.47)	2.83 (2.66-3.49)	2.44 (2.23-2.79)	2.31 (2.07-2.74)	1.48 (1.24-1.66)	45.9 (40-50)

Table 15. Measurements of two specimens of *Cuvierina (Urceolarica) inflata* (Bellardi, 1873) from the Pliocene of Estepona (locality Parque Antena), Spain, both illustrated in Janssen (2004, pl. 2, figs. 9, 10). H = shell height, W = shell width, Wa = width at aperture, Ws = width at septum, Pi = position of strongest inflation above base of septum.

locality	H (mm)	W (mm)	H/W	Wa (mm)	Ws (mm)	Pi (%)
Estepona	10.54	4.23	2.49	2.82	1.83	52
	8.05	4.32	1.86	2.90	1.91	54
mean (n = 2)	9.29	4.27	2.17	2.86	1.87	53

Janssen (2004, p. 113) included specimens illustrated by Ujihara (1996, p. 777, figs. 5.16-5.28, as *C. intermedia*) from Japan (Pliocene, Zanclean, Blow zones N18-20) in *C. inflata*, but even in these specimens the upper parts of the sidelines are concave. The inflation of the Japanese specimens is stronger than in Recent *C. urceolaris*; the Pangasinan material takes a position in between. It seems that these two *Cuvierina* populations form a gradual transition from *C. inflata* to *C. urceolaris*, which is also demonstrated by a few specimens from Pangasinan in which the upper parts of the sidelines are virtually straight. In the Mediterranean Basin, typical *C. inflata* is still present in Piacenzian deposits of Spain, indicating a (remote) synchronic occurrence of *C. inflata* and populations that already have to be identified as *C. urceolaris* during the early/middle Pliocene.

Family Cliidae Jeffreys, 1869

Genus *Clio* Linné, 1767

Type species – *Clio pyramidata* Linné, 1767 (Recent).

Subgenus *Balantium* Children, 1823

Type species – *Clio (Balantium) recurva* (Children, 1823) (Recent).

Remarks – Van der Spoel (1967, p. 76) cited this name as ‘*Balantium recurva* (sic) Children (sic), 1823,’ as a synonym of *Clio recurva* ‘Children,’ 1823 (the author’s name was repeated as such in van der Spoel & Dadon, 1999, p. 681). The name is spelled correctly (but incompletely) in van der Spoel’s (1967, p. 124) list of references, where it is erroneously referred to as ‘in Gray’ (repeated in van der Spoel, 1976b, p. 248, but here with the correct name ‘Children’). Children’s (1823) paper, in which *Balantium recurvum* was introduced (footnote, p. 220, pl. 7, fig. 107), was correctly referred to by Dance (1986, p. 235).

Clio (Balantium) cf. hataii (Noda, 1972)

Pl. 3, fig. 12; Pl. 24, fig. 8.

- ? 1972 *Cleodora hataii* Noda n. sp., p. 475, pl. 57, figs. 9-11.
- . 1979 *Euclio balantium* (Rang): Shibata, p. 117ff, pl. 20, figs. 2-5 (*non* Rang; in the explanation of pl. 20 erroneously as ‘*Euclia*’).
- ? 1984 *Clio balantium* forma *kakegawaensis* Shibata n. forma, p. 82, pl. 24, figs. 6, 7.
- ? 1986 *Clio balantium* forma *kakegawaensis* Shibata: Shibata *et al.*, p. 46, pl. 7, figs. 8, 9.
- ? 1990 *Clio hataii kakegawaensis* Shibata: Ujihara *et al.*, p. 314, pl. 1, fig. 9.
- ? 1996 *Clio hataii* (Noda): Ujihara, p. 776, figs. 3.12-3.18.

Description – Just a single adult specimen is available, preserved on a small slab of marlstone, showing its ventral side. Apical and apertural parts are missing; therefore, a possible dorso-ventral curvature of the specimen remains unknown. The shell has an apical angle of somewhat less than 90°; in its basal part the sides seem to have been slightly flexuous. The lateral margins have double carinae, with a very narrow flat sur-

face in between. The ventral surface has an obvious vertical central rib occupying one third of the shell's width. Furthermore, this side is covered with transverse folds, arched in apertural direction and starting at some distance from the apex, equally strong on the lateral fields and on the central rib. These folds touch the lateral carinae at a right angle.

Material examined – Anda3, RGM 517 718 (1; Pl. 3, fig. 12). Between the apical shell parts of *Clio cuspidata*, retaining their protoconch, one specimen (RGM 539 824; Pl. 24, fig. 8) is less strongly curved whereas its protoconch-1 is a bit more elongate. This specimen might also belong to the present species.

Discussion – The specimen differs from accompanying *Clio cuspidata* (see below) by a larger apical angle and non-concave sidelines, by its transverse ornament continuing on the ventral rib, as well as by the fact that the folds are not curved adaperturally close to the carinae. Noda (1972) recorded *Clio hataii* from the Japanese Kawabaru Member (Koyu Formation). The same species was illustrated by Ujihara (1996). Although Noda dated his specimens as 'Miocene,' both records originate from nannoplankton zones NN18-20 (Zanclean), according to Ujihara. This discrepancy led Janssen (2000b, p. 42) to consider the records of Noda and Ujihara to be different species, which most probably is incorrect.

The Pangasinan specimen resembles *C. hataii*, but has a wider apical angle and nothing is known about the dorsal side of the shell. *Clio lucai* Janssen, 2000b (p. 39, figs. 3-6), from the Pliocene/Early Pleistocene of northern Italy, is also similar. That species, too, has a narrower apical angle and its transverse ornament is coarser. In the absence of more and better preserved material the only available specimen is best identified as *Clio* cf. *hataii*. A closely related Japanese Miocene (N 8-9, Langhian) species is *Clio itoigawai* (Shibata, 1983, p. 73, pl. 2, figs. 1-3, as *Euclio itoigawai*).

Fragments identified as *C. balantium* (Rang), described and illustrated by Yamakawa & Ishikawa (1912, p. 6, pl. 1, fig. 7), could very well also belong to *C. hataii*. Their figure 7d-e shows that the transverse ornament touches the lateral carina perpendicularly, which is not the case in Recent '*C. balantium*' (= *C. recurva*). Furthermore, relatively well-preserved specimens from the Late Pliocene to Early Pleistocene of Japan, published by Shibata (1979; especially his fig. 4) as *Euclio balantium*, agree perfectly with the Pangasinan specimen, both in apical angle and ornament. A very similar form was introduced as *Clio balantium* forma *kakegawaensis* Shibata, 1984, also referred to in Shibata *et al.* (1986) (planktonic foram zone N 19-22 = Zanclean-Pleistocene) and Ujihara *et al.* (1990).

It seems that quite a number of transitional forms are present between *Clio hataii* and the Recent *C. recurva*. At any rate the Recent species differs from all fossil occurrences referred to above by its very fine transverse ornament on the early shell parts and by the fact that these transverse ribs touch the carinae at a significantly smaller angle.

Subgenus *Bellardiclio* Janssen, 2004

Type species – *Clio (Bellardiclio) cuspidata* (Bosc, 1802) (Recent).

Clio (Bellardiclio) cuspidata (Bosc, 1802)

Pl. 3, figs. 10, 11; Pl. 24, figs. 4, 5.

Synonymy – For references of Recent material see van der Spoel (1967, p. 73). The following document Quaternary and earlier occurrences only.

- 1867 *Cleodora cuspidata* Quoy e Gaym. (*sic*): Seguenza, p. 10, pl. 1, fig. 10a, b.
- 1880 *Cleodora cuspidata* Lamk. (*sic*) (*Hyalaea*): Seguenza, p. 276.
- . 1912 *Clio* (*s. str.*) *cuspidata* (Bosc): Yamakawa & Ishikawa, p. 5, fig. 1, pl. 1, fig. 6a-d.
- 1969 *Euclio cuspidata* (Bosc): Blanc-Vernet *et al.*, p. 220.
- . 1970 *Clio cuspidata* (Bosc): Colantoni *et al.*, p. 181, pl. 25, fig. 1a-c.
- 1971a *Clio cuspidata* (Bosc): Herman, p. 464ff.
- 1971b *Clio cuspidata* (Bosc): Herman, p. 614ff.
- . 1977 *Clio cuspidata* (Bosc): Almogi-Labin & Reiss, p. 8, pl. 1, figs. 5-8.
- . 1978 *Clio cuspidata* (Bosc): Buccheri, p. 134, pl. 2, fig. 7.
- . 1980 *Clio cuspidata* (Bosc): Buccheri *et al.*, p. 99, pl. 1, fig. 10.
- 1981 *Clio cuspidata* (Bosc): Herman, p. 178ff.
- 1981 *Clio cuspidata*: Torelli & Buccheri, p. 178.
- 1981 *Clio cuspidata* (Bosc): Buccheri & Torelli, p. 78.
- non 1982 *Clio cuspidata* (Bosc): Grecchi, p. 721, pl. 53, figs. 1, 2 (*non* Bosc = *C. braidensis?*).
- . 1983 *Clio cuspidata* (Bosc): Torelli & Buccheri, p. 160ff, pl. 2, fig. 4.
- . 1984 *Clio cuspidata* (Bosc): Grecchi, p. 17, pl. 1, fig. 7.
- 1984 *Clio cuspidata* (Bosc): Buccheri, p. 80.
- . 1984 *Clio cuspidata* (Bosc): Shibata, p. 81, pl. 24, figs. 4, 5.
- 1985 *Clio cuspidata* (Bosc): Buccheri, p. 119.
- . 1988 *Clio cuspidata* (Bosc): Grecchi & Bertolotti, p. 109, pl. 1, fig. 6.
- . 1989 *Clio cuspidata*: Biekart, p. 208, pl. 2, fig. 3.
- 1992 *Clio cuspidata* (Bosc): Buccheri & Bertoldo, p. 497, 498.
- 1994 *Clio cuspidata* (Bosc): Buccheri *et al.*, 1994, p. 146, 147.
- 1996 *Clio cuspidata* (Bosc): Ujihara, p. 776, fig. 3.22.
- v? 1999a *Clio cuspidata* (Bosc)?: Janssen, p. 21, pl. 3, fig. 12.
- v. 2004 *Clio (Bellardiclio) cuspidata* (Bosc, 1802): Janssen, p. 114, pl. 3, figs. 3, 4.

Description – See van der Spoel (1967, p. 73, figs. 65, 66) and Bé & Gilmer (1977, p. 781, pl. 5, fig. 15a-d).

Material examined – Anda1, RGM 517 719 (2, 1 fragment), RGM 517 720 (16 fragments, 7 protoconchs), RGM 517 733 (1), RGM 539 825 (1 protoconch; Pl. 24, fig. 5); Anda2, RGM 517 721 (1: Pl. 3, fig. 11), RGM 517 722 (1: Pl. 3, fig. 10), RGM 517 723 (1), RGM 517 724 (11 fragments, 4 protoconchs); Anda3, RGM 517 725 (8 fragments, 4 protoconchs); Anda4, RGM 517 726 (1 internal mould), RGM 517 727 (16 fragments, 4 protoconchs), Anda6, RGM 517 728 (2 fragments); AndaClif1, RGM 429 290 (1 protoconch); AndaClif3, RGM 429 323 (9 fragments); AndaDeVos, RGM 517 729 (5 fragments), RGM 539 823 (1 protoconch; Pl. 24, fig. 4); Roxas, RGM 517 730 (1 protoconch); Tiep1, RGM 517 731 (1 fragment); Tiep5, RGM 517 732 (2 fragments).

Discussion – This species is primarily represented by fragments. Just a few specimens could be saved more completely on slabs of marl.

The illustrations in van der Spoel (1967) represent an untypical specimen with very faint transverse ornament. In the Pangasinan specimens discussed herein, however,

this ornament is stronger and agrees fully with compared Pliocene specimens from Spain (Janssen, 2004) of this species. On the ventral side of the shell (Pl. 3, fig. 10), the transverse ribs are interrupted on the central rib and merely change to narrow grooves. Also, the shape and size of the protoconchs agree perfectly with compared Recent material (RGM collections). In most specimens retaining their larval shell the apical spine on protoconch-1 is preserved (Pl. 24, figs. 4, 5).

Clio cuspidata was only rarely recorded as a fossil older than Pleistocene. From the Pacific area there are a few occurrences in Japan (Yamakawa & Ishikawa, 1912; Ujihara, 1996). From the Mediterranean realm Seguenza (1867) reported it from the 'calcare Pliocenico' of S. Filippo near Messina and from the 'marne gialle' of Pietrazza (both Sicily, Italy), and Seguenza (1880, p. 276) from the Middle/Late Pliocene ('Astiano') of Calabria (southern Italy). Janssen (2004, p. 114, pl. 3, figs. 3, 4) noted the presence of *C. cuspidata* in Piacenzian strata of Estepona in southeast Spain.

Grecchi (1982) found two incomplete specimens that, according to the illustration, have three central ribs on the dorsal side and, therefore, rather belong to the forerunner species *C. braidensis* (Bellardi, 1873). Janssen (1999a, p. 21, pl. 3, fig. 12) described a doubtful specimen from the Early to Middle Pliocene of the Dominican Republic that might also belong to *C. braidensis*.

Subgenus *Clio sensu stricto*

Clio (Clio) convexa convexa Boas, 1886

Pl. 3, fig. 13; Pl. 4, figs. 1, 3; Pl. 24, figs. 6, 7.

Synonymy – References for *Clio convexa sensu lato*.

- * 1886 *Cleodora pyramidata* (L.) var. *convexa* Boas, pp. 73, 203, pl. 6, fig. 97a-d.
- ? 1913 *Clio pyramidata convexa* (Boas): Tesch, p. 37, fig. 33.
- . (1960) *Clio teschi* n. sp. McGowan, p. 101, fig. 35 (*nomen nudum*).
- . 1967 *Clio pyramidata* Linnaeus forma *convexa* (Boas): van der Spoel, p. 70, figs. 55, 59.
- . 1973 *Clio pyramidata* Linnaeus forma *convexa* (Boas): van der Spoel, p. 17, figs. 1-8 (with lectotype designation).
- . 1976b *Clio pyramidata* forma *convexa* Boas: van der Spoel, p. 190, fig. 33a, b.
- . 1977 *Clio convexa* (Boas): Bé & Gilmer, p. 773, pl. 7, figs. 20a-e.
- . 1979 *Clio convexa* syn. *Clio pyramidata* forma *convexa* (Boas): Richter, p. 16, pl. 2, fig. 15a-c.
- . 1982 *Clio convexa* (Boas, 1886): Almogi-Labin, p. 58, pl. 2, fig. 7.
- v. 1999a *Clio pyramidata* (Linné) forma *lanceolata* (Lesueur): Janssen, p. 21, pl. 3, figs. 14a-d, 18a-c (partim, *non pyramidata* Linné, *nec lanceolata* Lesueur; *non* figs. 13, 15, 16 = *C. pyramidata* f. *lanceolata*).
- v. 1999a: *Clio* sp. Janssen, p. 22, pl. 3, fig. 18a-c.
- . 2002 *Clio convexa convexa* (Boas): Rampal, p. 237, figs. 15D, 16F-L.

Description – *Clio convexa* for a long time was considered a variety (forma) or subspecies of *C. pyramidata*. It differs from that species especially by its doubled lateral carinae with squarish transverse section, starting almost immediately after the protoconch (Pl. 24, figs. 6, 7). In *C. pyramidata* the initial part of the teleoconch is circular, as the rounded lateral carinae start later (Pl. 24, fig. 10). The protoconch in *C. convexa* is relatively more thickset than in *C. pyramidata*. The adult shell of *C. convexa* has a height of approximately 7 mm, whereas fully grown *C. pyramidata* reaches more than double that size.

Material examined – Anda1, RGM 517 734 (3), RGM 517 735 (many), RGM 517 736 (1; Pl. 3, fig. 13, Pl. 4, fig. 3), RGM 517 737 (1 aberrant specimen); Anda2, RGM 517 738 (7), RGM 517 739 (7), RGM 517 740 (many), RGM 539 829 (1; Pl. 24, fig. 6), RGM 539 830 (1; Pl. 24, fig. 7); Anda3, RGM 517 741 (8), RGM 517 742 (many), RGM 517 743 (1 aberrant specimen); Anda4, RGM 517 744 (8 juveniles); Anda6, RGM 517 745 (6 juveniles); Anda-Clif1, RGM 429 289 (38, 4 fragments); AndaDeVos, RGM 517 746 (5 juveniles); Roxas, RGM 517 747 (23 juveniles); Tiep1, RGM 517 748 (1 juvenile); Tiep2, RGM 517 749 (5 fragments); Tiep3, RGM 517 750 (20 juveniles); Tiep4, RGM 517 751 (4 juveniles); Tiep5, RGM 517 752 (29 juveniles).

Discussion – The distinction of *Clio convexa*, introduced as a variety of *C. pyramidata* by Boas (1886) (see van der Spoel, 1967, p. 70), has been problematic. Van der Spoel (1969) devoted a long paper to this subject, even using photometric methods to interpret shell growth, to find differences between the formae *convexa* and *lanceolata*. He found that these forms of *C. pyramidata* differ in size and shape of the embryonic shell. As the most important distinguishing characteristic, viz. the presence of double carinae, is not even mentioned in that paper, van der Spoel obviously, and unfortunately, compared two forms of the real *C. pyramidata*!

Van der Spoel (1973) studied the type material of *convexa* and described the double carinae thus: 'The lateral sides are provided with flattened and sometimes partly concave margins. This structure is continuous from the aperture to the embryonic shell.' In the same paper he designated a lectotype (van der Spoel, 1973, pp. 5, 6). But the taxon is still indicated as *Clio pyramidata* forma *convexa*. The lectotype, from the Indian Ocean (Bay of Bengal), distinctly shows the doubled carinae.

In an unpublished thesis, McGowan (1960) described the present species as *C. teschi*. Bé & Gilmer (1977), Richter (1979) and later authors correctly also stated that *C. convexa* merits the status of independent species.

Extant *Clio convexa* occurs only in the Indian (inclusive of the Red Sea, see below) and southern Pacific oceans (Bé & Gilmer, 1977, fig. 19), apart from occasional specimens strayed into the South Atlantic because of currents (Rampal, 2002, p. 238). Therefore, several records of this species from the Atlantic Ocean (e.g. Bonnevie, 1913, p. 30, fig. 22C; Tesch, 1913, p. 37; van der Spoel, 1962, p. 194, diagram 1; van der Spoel, 1969) have to be considered erroneous and most probably represent forms of *Clio pyramidata*.

Herman (1971a) recorded Late Quaternary specimens from the Red Sea. The only known occurrence in the Atlantic realm is the unmistakable specimen from the Caribbean Early Pliocene Gurabo Formation (Dominican Republic) illustrated in Janssen (1999a, as *Clio pyramidata* f. *lanceolata*, corrected in Janssen, 2004, p. 115).

A new subspecies, *Clio convexa cyphosa* Rampal, 2002 (p. 240, figs. 16A-E, 23A, B), was based on specimens from the Red Sea, constantly differing from the Indian and Pacific Ocean specimens by the fact that in lateral view the dorsal side of the shell shows a hump-backed shape, with the adapical portion concave and the adapertural half convex. In Indo-Pacific specimens the shape is gradually convex. These differences could indeed be acknowledged on several Red Sea and Indo-Pacific Ocean samples.

The Pangasinan specimens are usually too small (juvenile or broken) to estimate this feature. But all specimens reaching comparable size differ from both the Red Sea and the Indo-Pacific Recent type, as described by Rampal. In these shells the outline of

the dorsal side is neither convex nor hump-backed, but always concave. Apparently, however, a similar shape occurs also in the Recent fauna near the Philippines (Bé & Gilmer, 1977, p. 773, pl. 7, fig. 20e) and therefore a new subspecies is not erected here. Outline drawings of these three morphs are given (Pl. 4, figs. 1-3).

Interesting are the differences in frequencies of the present species compared to *Clio pyramidata* f. *lanceolata* in the various Pangasinan samples. Although both co-occur in most samples (apart from Anda5 and AndaClif1 that only yielded *C. pyramidata* f. *lanceolata*), there are striking differences in numbers. Generally speaking, *C. convexa* is the most common of the two, but its numbers are lowest in samples in which *C. pyramidata* is more common (compare Table 26). This situation might be caused by both taxa occupying the same ecological niche, as a result of which sometimes the first, sometimes the second species predominates. This is strongly reminiscent of the actual situation in the Red Sea, where *C. convexa* is common and *C. pyramidata* is absent.

***Clio (Clio) pyramidata* Linné, 1767 forma *lanceolata* (Lesueur, 1813)**

Pl. 4, fig. 4; Pl. 24, figs. 9, 10.

- * 1813 *Hyalaea lanceolata* Lesueur, p. 285, pl. 5, fig. 3.
- 1967 *Clio pyramidata* Linnaeus forma *lanceolata* Lesueur: van der Spoel, p. 68, fig. 51a-c (with extensive synonymy).
- ? 1972 *Cleodora okinawana* Noda n. sp., p. 477, pl. 57, figs. 6, 12, 13.
- v. 1995 *Clio pyramidata* Linné forma *lanceolata* Lesueur: Janssen, p. 83, pl. 7, figs. 3-5 (with extensive synonymy of fossil occurrences).
- . 1999 *Clio pyramidata* Linnaeus forma *lanceolata* (Lesueur): van der Spoel & Dadon, p. 681, fig. 6.40.
- v. 1999a *Clio pyramidata* Linné forma *lanceolata* Lesueur: Janssen, p. 21, pl. 3, figs. 3, 13, 15-17 (*non* fig. 14 = *Clio convexa*).
- non v 1999a *Clio pyramidata* Linné forma *lanceolata* (Lesueur): Janssen, p. 21, pl. 3, fig. 14 (*non pyramidata* Linné, *nec lanceolata* Lesueur = *Clio convexa*).
- v. 1999a *Clio* sp.: Janssen, p. 22, pl. 3, fig. 18.
- . 2002 *Clio pyramidata lanceolata* (Lesueur): Rampal, p. 237, figs. 12, 13.
- v 2004 *Clio (Clio) pyramidata* Linnaeus f. *lanceolata* (Lesueur): Janssen, p. 115, pl. 3, figs. 1, 2.

Description – See van der Spoel (1967) and Rampal (2002).

Measurements – Van der Spoel (1975, p. 188) gave protoconch measurements for three groups of Atlantic *Clio pyramidata*. These groups were ‘tropical form,’ ‘transitional form’ and ‘coldwater form’. He gave figures for protoconch height (‘length’ in his paper) and width. The same measurements (Table 16) were taken from 24 specimens in the Pangasinan material (from various locations).

The almost perfect match of the fossil Pangasinan measurements with van der Spoel’s ‘tropical form’ is striking. The measurement range for protoconch height in the Philippine specimens is 0.30-0.37 mm which again agrees completely with van der Spoel’s data given in his figure 1. Within this range fall his three ‘tropical form’ stations (7-9).

Material examined – Anda1, RGM 517 753 (3 fragments, 9 protoconchs); Anda2, RGM 517 754 (3, 3 fragments, 12 protoconchs); Anda3, RGM 517 755 (10 protoconchs); Anda4, RGM 517 756 (2), RGM 517 757 (many), RGM 517 758 (1; Pl. 4, fig. 4), RGM 539

831 (1; Pl. 24, fig. 9), RGM 539 832 (1; Pl. 24, fig. 10); Anda5, RGM 517 759 (1); Anda6, RGM 517 760 (4), RGM 517 761 (12 fragments, 4 protoconchs); AndaClif1, RGM 429 291 (1 protoconch); AndaClif3, RGM 429 324 (23 fragments, 6 protoconchs); AndaDeVos, RGM 517 762 (14 fragments, 8 protoconchs); Roxas, RGM 517 763 (1 protoconch); Tiep1, RGM 517 764 (20); Tiep2, RGM 517 765 (1, 1 fragment); Tiep3, RGM 517 766 (3 protoconchs); Tiep4, RGM 517 767 (2 fragments); Tiep5, RGM 517 768 (2 protoconchs).

Discussion – See the discussion of *Clio convexa*, above, for notes on the relative frequencies of that species and *C. pyramidata*. As is clear from the numbers of specimens (see also Table 26), *C. pyramidata* is common in those samples in which *C. convexa* is rare and *vice versa*.

Clio pyramidata sensu lato in the extant fauna is a very common pteropod species with a large distribution and a wide range of morphological differences, usually interpreted as formae. The typical form, *C. pyramidata sensu stricto*, has a restricted distribution in the northern Atlantic Ocean, approximately between 40 and 70° N, but according to Tesch (1913, p. 36) also occurring in the eastern part of the southern Pacific Ocean. The forma *lanceolata*, on the contrary, has a much larger distribution and occurs worldwide in tropical and subtropical waters, Red Sea excluded. Richter (1979, p. 15) obviously mistook f. *lanceolata* for f. *pyramidata sensu stricto*. The main distinguishing characteristic between forma *pyramidata sensu stricto* and forma *lanceolata* (see Tesch, 1913, pp. 35, 36; van der Spoel, 1967) is the general shape of the shell, with not or only faintly diverging lateral carinae in forma *pyramidata* and strongly diverging carinae in forma *lanceolata*. In samples from the northern Atlantic it is not always possible to separate these two formae and intermediate specimens commonly occur. Furthermore, forma *lanceolata* demonstrates a considerable variability depending on geographical distribution (Rampal, 2002, p. 237). Several further forms of *C. pyramidata* are distinguished, mainly in the southern (Antarctic) seas, the true status of which is not yet ascertained.

The Pangasinan material as a rule is too small (juvenile or broken) to decide which forma is represented. A few larger specimens, however, all have diverging sidelines, and thus the complete material is identified as forma *lanceolata*. Cainozoic specimens of forma *pyramidata* are not yet known.

Contrary to Rampal (2002), *lanceolata* is not treated here as a subspecies, although the geographical distributions seem to support a subspecific rank. A decision in this matter, however, should be taken in a reconsideration comprising all formae ascribed to *C. pyramidata*.

Table 16. Mean values for protoconch measurements of *Clio pyramidata* Linné, 1767.

	height	width	n
Van der Spoel (1975):			
tropical form	0.332 mm	0.187 mm	50
transitional form	0.408 mm	0.203 mm	72
coldwater form	0.355 mm	0.213 mm	31
This paper:			
Pangasinan	0.331 mm	0.187 mm	24

Family Cavoliniidae Gray, 1850

Remarks – Subfamilies Creseinae, Cuvierinae and Cliinae, traditionally included in the Cavoliniidae, were raised to family level recently (Janssen, 2003, 2006). Therefore, just a few genera remain in the Cavoliniidae *sensu stricto*, viz. *Cavolinia*, *Diacavolinia* and *Diacria* for Recent species. Fossil *Cavolinia* and *Diacria* species were known already, and several new species in these genera, as well as a first *Diacavolinia* from the fossil record, are described below. Additionally, the exclusively fossil genera *Diacrolinia*, *Edithinella*, *Gamopleura* and *Vaginella* are included in the Cavoliniidae. Rampal (1996, 2002) believed *Vaginella* to be ancestral to *Cuvierina*, but gave no argument in support of this hypothesis. One could find reasons to assign *Vaginella* either to the Cuvierinidae or to the Cavoliniidae, a topic that merits a more detailed study.

Genus *Cavolinia* Abildgaard, 1791

Type species – *Cavolinia tridentata* (Niebuhr, 1775) (Recent).

Remarks – Representatives of the genus *Cavolinia* are quite common in most Pangasinan samples, but as a rule rather fragmental. Locality Tiep2, however, yielded a comparatively high number of well-preserved specimens. From most other localities a number of shells could be saved more or less completely by careful preparation, usually on small slabs of matrix. All such specimens had to be impregnated with artificial resin. Identification of fragmentary material was laborious, especially so for broken ventral shell parts, which offer only little characteristics, in particular, if both lateral spines are lacking. The apical shell parts usually are broken off, but quite a number of isolated protoconchs were collected. Identification of these appeared to be virtually impossible. They are included in the collection as *Cavolinia* sp. indet., together with a number of unidentifiable fragments of other shell parts. The number of no less than nine *Cavolinia* species in the present material is surprisingly high. Three of them appear to be new to science and are described below as *C. baniensis* sp. nov., *C. perparvula* sp. nov. and *C. shibatai* sp. nov.; two species are represented by insufficient material, and are listed as *Cavolinia* sp. 1 and 2.

Cavolinia baniensis sp. nov.

Pl. 4, fig. 5.

Holotype – RGM 517 773 (Pl. 4, fig. 5).

Type locality – Tiep2 (Bani municipality, Luzon, Pangasinan, Philippines), temporary drainage excavation, along road from Bani to Bolinao at co-ordinates N 16° 13' 54.3" E 119° 51' 36.2", map-sheet 6975-II Alaminos (Fig. 2).

Stratum typicum – Clayey level in interbedded marlstone, sandstone and claystone below Bolinao Limestone, Pliocene.

Derivatio nominis – Named after the municipality of Bani, in which the type locality is situated.

Paratypes – Anda2, RGM 517 769 (3); AndaDeVos, RGM 517 770 (1, 9 fragments); Roxas, RGM 517 771 (2 fragments); Tiep2, RGM 517 772 (10), RGM 517 774 (13 fragments).

Diagnosis – Medium-sized *Cavolinia* (see Table 16) resembling the Recent *C. globulosa* (d'Orbigny, 1836), but dorsal shell part with five radial ribs: a wide central one and two sets of lateral ribs, separated by a narrow interspace, the ones next to the central rib about half as wide as the outer ones.

Description – Medium-sized *Cavolinia* species (H to over 6 mm). The shell is higher than wide, with its greatest width approximately at half the shell height, far above the lateral spines. The dorso-ventral diameter is roughly the same as the shell width. Lateral spines weakly developed and straight. The ventral shell part is very globular with its strongest curvature at about two thirds of its height. There is a concave part close to the reflected apertural margin. A transverse ornament is especially well-developed on the most convex part of the ventral side. This ornament is rather variable, but on average there are some 20 well-defined ridges, that decrease in strength towards the aperture and on the lower part of the shell, where just some growth lines are seen. In their middle these transverse ridges, as well as the growth lines, are somewhat curved in adapical direction. A few radial lines are visible in floodlight on the middle part of the ventral shell part. Inner lip recurved, not visible in a straight ventral view.

Dorsal side not as convex as the ventral one, but the apertural margin strongly overhanging the ventral part and aperture. There are five radial ribs of which the middle one is the strongest. It is well-separated from both sets of two lateral ribs, of which the inner ones are half as wide as the outer ones, and separated by a narrow and shallow groove only. Lateral areas are slightly swollen on their inner sides, separating a not very strong marginal ridge. Tip of apical spine broken in all specimens, but curved in dorsal direction. There is no clearly separated apertural lip.

Measurements – Dimensions of nine specimens are given in Table 17.

Discussion – This species resembles the Recent *Cavolinia globulosa*, but differs by a number of features. A Recent specimen of this latter species is illustrated here for

Table 17. Dimensions in mm of the holotype and eight paratypes of *Cavolinia baniensis* sp. nov.

Locality	shell height	shell width	width between lateral spines	dorso-ventral diameter
Anda2	7.64	6.06	5.06	-
AndaDeVos	8.96	-	-	-
Tiep2	6.47	5.31	3.98	4.90 holotype
	6.39	5.06	3.82	4.56
	6.47	5.23	-	4.73
	6.06	4.98	3.74	4.48
	5.89	4.90	3.40+	4.40
	-	5.15	4.07	4.90
	-	5.23	4.15	4.98
	-	-	-	-

comparison (Pl. 4, fig. 6). The proportions of the shell are similar, with the greatest width above the not very well-developed lateral spines. The ventral shell part in the new species, however, is regularly curved, but more strongly so in *C. globulosa*, in which species the curvature can even be a bit angular, resembling the Recent species *C. gibbosa* (d'Orbigny, 1836). The radial ornament on the dorsal side in *C. globulosa* shows three almost equally wide ribs, separated by vague and narrow interspaces. In *C. baniensis*, however, the ribs on both side of the central one are subdivided into two ribs, a narrow inner and a wider outer one. The lateral areas in *C. globulosa* are less swollen.

***Cavolinia landaui* Janssen, 2004**

Pl. 4, fig. 7; Pl. 5, fig. 1.

*v 2004 *Cavolinia landaui* Janssen sp. nov., p. 116, pl. 3, fig. 7a-c.

Description – See Janssen (2004). In the description of this species it was erroneously said that the lateral spines developed on the dorsal side only. As is clear from the illustration this should be the ventral side, of course.

Material examined – Anda1, RGM 517 775 (35), RGM 517 775 (many fragments), RGM 517 777 (1; Pl. 4, fig. 7); Anda2, RGM 517 778 (many), RGM 517 779 (many fragments); Anda3, RGM 517 780 (12), RGM 517 781 (7 fragments); Anda4, RGM 517 782 (3), RGM 517 783 (1; Pl. 5, fig. 1), RGM 517 784 (many fragments); Anda6, RGM 517 785 (2 fragments); AndaClif3, RGM 429328 (2, 6 fragments), RGM 429 330 (7 fragments); AndaDeVos, RGM 517 786 (2, 16 fragments); Roxas, RGM 517 787 (6 fragments); Tiep2, RGM 517 788 (5 fragments); Tiep3, RGM 517 789 (2 fragments).

Discussion – The quite abundant specimens in the Pangasinan material agree very well in shape, as well as in ornament of the dorsal shell part, with the material described from the Spanish Piacenzian. They reach slightly larger size (H up to approximately 7 mm, compared to 5 mm for the Spanish shells) and on the ventral shell part there are two vague radial grooves that are absent in the Spanish specimens. These differences, however, are insufficient for a taxonomical subdivision. Again, as was also said for the Spanish material, it is surprising that, apparently, this species has not been found before in this area; in the Pangasinan localities this is one of the most common cavoliniids. *Cavolinia landaui*, however, could not yet be recognised in the Japanese pteropod literature. These two remote occurrences of the same species again offer a nice opportunity for long distance correlation.

***Cavolinia perparvula* sp. nov.**

Pl. 5, figs. 2, 3.

Holotype – RGM 517 794 (Pl. 5, fig. 2).

Type locality – Anda4, Cabarruyan Island (Pangasinan, Philippines), coastal cliff section at co-ordinates c. N 16° 17.413' E 119° 56.197', map-sheet 6975-I, Bolinao (Fig. 1).

Stratum typicum – Greyish-brown marlstone, in interbedded sandstone, siltstone and claystone, below Bolinao Limestone, Pliocene.

Derivatio nominis – From L. *per* (adv.) - very, and *parvulus* (adj.) - small; *perparvula* = very small.

Paratypes – Anda1, RGM 517 790 (3 fragments); Anda2, RGM 517 791 (5, 3 fragments); Anda3, RGM 517 792 (5, 10 fragments); Anda4, RGM 517 793 (24, 40 fragments), RGM 517 795 (1; Pl. 5, fig. 3); Anda6, RGM 517 796 (1, 11 fragments); AndaClif1, RGM 429 294 (1, 1 fragment); AndaClif3, RGM 429 329 (8 fragments); AndaDeVos, RGM 517 797 (5, 5 fragments); Roxas, RGM 517 798 (7 fragments).

Diagnosis – Very small ($H < 2$ mm) *Cavolinia*, with three vague radial ribs on the dorsal shell part. Ventral side slightly convex and virtually smooth. Dorsal apertural margin swollen, clearly separated from the lower shell parts and overhanging the aperture. In frontal view the dorsal apertural margin is somewhat widened at the place of the central radial rib.

Description – Strikingly small ($H < 2$ mm), but otherwise quite typical *Cavolinia* species. The shell is approximately 1.3 times higher than wide, with a clearly separated apical shell part curved in dorsal direction. The greatest shell width is at the lateral spines. These are usually not very strongly developed and straight, but pointing downwards in some specimens. The ventral shell part is somewhat swollen, with strongest curvature above the middle of the shell height. A transverse ornament on the most convex part as seen in most cavoliniids is only vaguely indicated (in some specimens just some faint growth lines are visible) or absent. The ventral apertural margin is straight and thickened, but could be observed in few specimens only, as the aperture of most shells is filled with matrix. The dorsal shell part is rather convex and has three vaguely delimited radial ribs of equal strength, separated by just slightly narrower interspaces. The dorsal apertural margin is swollen and strongly overhangs the aperture; it is separated from the lower shell parts by a distinct boundary. The middle radial rib continues on the apertural margin, forming a widening, but not really a rostrum, on the margin (ventral view).

Measurements – Eight sufficiently complete specimens could be measured (Anda4, six specimens; Anda6 and AndaDeVos, one specimen each) (Table 18).

Discussion – The closest resemblance of this species is to *Cavolinia ventricosa* (Guppy, 1882), a lectotype for which was designated by Janssen (1998, p. 102, pl. 2, figs. 4-8). Although also a small *Cavolinia* species, *C. ventricosa* has more than double the size of *C. perparvula* and has very different proportions; particularly, the dorsal shell part in *C. ventricosa* is considerably more convex than in *C. perparvula* and its dorsal apertural lip is much more projecting. The three radial ribs on its dorsal side are differently developed, with the middle narrower than the lateral ones, and also they are markedly stronger and better defined. The apical shell portion in *C. perparvula* is relatively larger and apparently the larval shell is more strongly recurved dorsally.

Table 18. Measurements for eight specimens of *Cavolinia perparvula* sp. nov.

	Shell height	shell width	dorso-ventral diameter	lateral spines % from apex
Range in mm	1.80-1.96	1.24-1.48	0.76-0.92	30-36
mean value	1.85	1.40	0.86	33.1

***Cavolinia shibatai* sp. nov.**

Pl. 5, figs. 4-6.

- . 1979 *Cavolinia longirostris longirostris* (Lesueur): Shibata, p. 119, pl. 19, figs. 25-28 (*non* Lesueur).
- . 1984 *Cavolinia longirostris* forma *longirostris* (Blainville): Shibata, p. 86. pl. 25, figs. 5, 6 (*non* de Blainville).
- . 1996 *Cavolinia* sp.: Ujihara, p. 785, fig. 7.15.

Holotype – RGM 517 813 (Pl. 5, fig. 5).

Type locality – Tiep2 (Bani municipality, Pangasinan, Philippines), temporary drainage excavation along road from Bani to Bolinao at co-ord. N 16° 13' 54.3" E 119° 51' 36.2", map-sheet 6975-II Alaminos (Fig. 1).

Stratum typicum – Clayey level in interbedded marlstone, sandstone and claystone below Bolinao Limestone, Pliocene.

Derivatio nominis – The species is named after Professor Hiroshi Shibata (Laboratory of Geology, College of General Education, Nagoya University, Nagoya, Japan), who contributed substantially to the knowledge of Cainozoic holoplanktonic molluscs from Japan.

Paratypes – Anda1, RGM 517 799 (2), RGM 517 800 (6), RGM 517 801 (13 fragments); Anda2, RGM 517 802 (5), RGM 517 803 (5); RGM 517 804 (many fragments), RGM 517 819 (1; Pl. 5, fig. 6); Anda3, RGM 517 805 (3), RGM 517 806 (2, 5 fragments); Anda4, RGM 517 807 (6), RGM 517 808 (7, 18 fragments); Anda6, RGM 517 809 (1); AndaClif3, RGM 429 325 (2 fragments); AndaDeVos, RGM 517 810 (2 fragments); Roxas, RGM 517 811 (2 fragments); Tiep2, RGM 517 812 (7), RGM 517 814 (1; Pl. 5, fig. 4), RGM 517 815 (many fragments); Tiep3, RGM 517 816 (5 fragments); Tiep 4, RGM 517 817 (1, 1 fragment); Tiep5, RGM 517 818 (2 fragments).

Diagnosis – *Cavolinia* species resembling *Diacavolinia* in general shape, but retaining larval shell. Outline triangular. Ventral side swollen, upper part with clear concentric ribs. Dorsal side less convex, with five radial ribs, lateral ones close and more separated from central one. Lateral spines well-developed, pointing downwards. Dorsal apertural margin with a distinct rostrum. Apical spine curved dorsally.

Description – *Cavolinia* of roughly triangular shape with well-developed lateral spines that usually are broken. Apical spine retained, not shed, but also usually broken.

Greatest shell width is at the lateral spines. The ventral shell part is moderately convex and has clear transverse riblets in its upper part. Two vague radial lines are present, running from the base of the shell towards the interlocking systems. Ventral apertural margin gradually curved, slightly bent outward. The lateral spines are formed by extensions of the ventral shell part, dorsally they are much shorter (Pl. 5, fig. 6), when preserved they point more or less downwards (Pl. 5, fig. 4). Dorsal shell part less convex than ventral side, with an ornament of five radial ribs. The central rib continues into the apertural margin, and forms a clear and well defined snout-like compression or rostrum. The lateral ribs lay close together, more separated from the central one. Growth lines are especially well-developed on the rostrum and upper part of the central rib.

Measurements – The holotype and eleven paratypes were measured (Table 19). Values for shell height and shell width for all specimens are too low, as the larval shell is partly missing in all specimens and the lateral spines are practically always damaged. The most complete specimens were measured, so the differences in size are not only caused by damage. Shells from locality Tiep2 are markedly larger than those from Anda1 and 2.

Discussion – In general shell form and especially the shape of the apertural lip with a well-defined rostrum this species closely resembles species of the genus *Diacavolinia*, from which it differs basically by the fact that the larval shell is retained, not shed. The well-defined rostrum distinguishes the present species from all other known *Cavolinia* species. The specimens illustrated by Shibata and Ujihara (see synonyms) resemble the present new species to such an extent that they may be presumed identical. They cannot belong to *Cavolinia longirostris* (de Blainville, 1822), nowadays *Diacavolinia longirostris*, as ‘the posterior spine is present in most specimens’ (Shibata, 1984). The Japanese form is recorded by Shibata (1984, p. 74) from Blow zones N19 to N22 (Zanclean-Piacenzian). Material referred to by Ujihara (1996) is from the upper part of zone N 20 (Zanclean).

Table 19. Measurements of holotype and eleven paratypes of *Cavolinia shibatai* sp. nov.

Locality	shell height	shell width	dorso-ventral diameter
Anda1	3.40	3.24	1.91
Anda2	4.23	3.15	2.24
	4.23	3.82	2.49
	3.90	2.99	2.16
	3.90	3.98	2.24
	6.14	4.98	3.07
Tiep2	6.31	4.32	3.24
	4.81	4.07	2.66
	4.48	3.57	2.16
	4.81	4.65	2.66
	4.48	4.07	2.24
	5.89	4.65	2.90 (holotype)

***Cavolinia tridentata* (Niebuhr, 1775)**

Fig. 8; Pl. 5, fig. 7.

Synonymy – For extensive synonyms of Recent occurrences see van der Spoel (1967, p. 94), to which should be added the following.

- . 1878 *Cavolinia tridentata* (*Anomia*) Forskal: Tiberi, p. 69.
- . 1880 *Cavolinia tridentata* (*Anomia*) Forskal: Tiberi, p. 29.
- . 1905 *Cavolinia tridentata* Forsk. sp. (*Anomia*): Bellini, p. 31.
- ? 1921 *Cavolinia tridentata* Forskäl n. subsp.: Vaughan & Woodring, p. 137.
- . 1928 *Cavolina telemus* (Linné): Woodring, p. 113, pl. 1, figs. 6, 7.
- . 1934 *Cavolina telemus* (Linné): Collins, p. 188, pl. 8, figs. 4-7.
- . 1972 *Cavolinia telemus* Linnaeus: Noda, p. 479, pl. 57, figs. 14-17, 19, 20, 22-26, 29-31.
- . 1974 *Cavolinia tridentata* (MS. Forskäl) (Niebuhr): van der Spoel, p. 100ff, figs. 4-6 (including synonymy).
- . (1975) *Cavolinia tridentata*: Rampal, p. 198, figs. 52, 53.
- . 1976b *Cavolinia tridentata* (ms. Forskäl) (Niebuhr): van der Spoel, p. 55ff, figs. 48-56 (including synonymy).
- ? 1982 *Cavolinia tridentata* (ms. Forskäl) (Niebuhr): Grecchi, p. 724, pl. 52, fig. 6a, b (partim? *non* Niebuhr?).
- . 1989 *Cavolinia tridentata* (Niebuhr): Lalli & Gilmer, p. 151ff, colour fig. 7.
- v. 1998 *Cavolinia tridentata* (Niebuhr): Janssen, p. 102, pl. 2, fig. 1.
- v. 1999a *Cavolinia* cf. *tridentata* (Niebuhr): Janssen, p. 25, pl. 5, figs. 1-3.
- v. 2004 *Cavolinia tridentata* (Niebuhr): Janssen, p. 117, pl. 4, figs. 2a, b, 3.

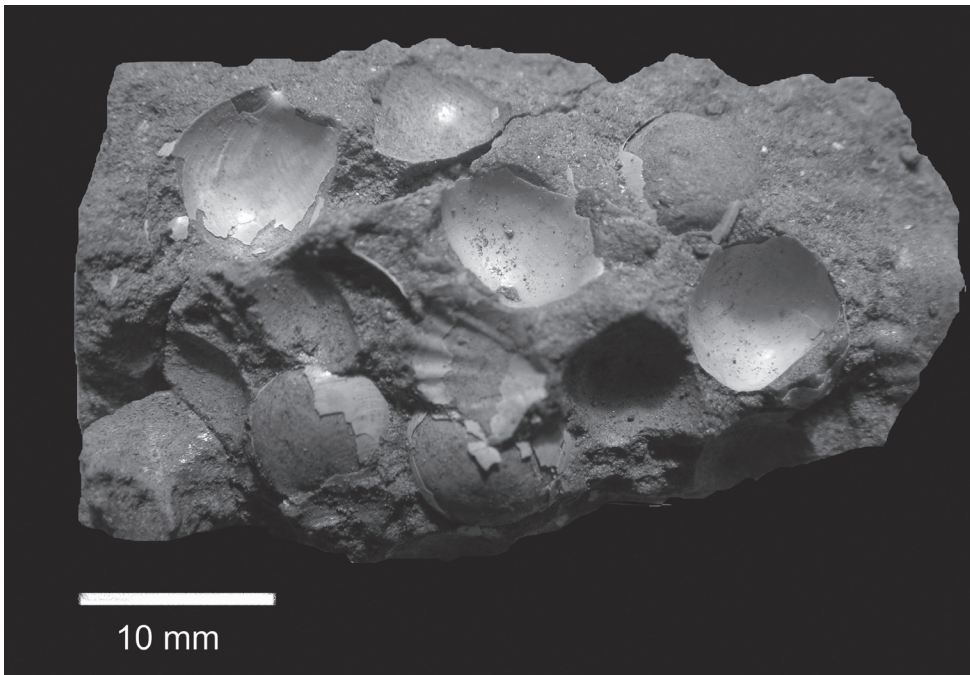

Fig. 8. Cluster of poorly preserved *Cavolinia tridentata*, from locality Anda1 (RGM 517 824).

Description – Largest *Cavolinia* species (H to over 12 mm). The ventral shell part is swollen with an almost flat to slightly concave area close to the somewhat reflected apertural margin. Growth lines are clear, irregular in strength and in most specimens not developed as a transverse ornament, as in many other species of this genus. In just a few shells they are regularly spaced and somewhat stronger developed on and above the point of strongest curvature. In their middle part they are slightly recurved in apical direction. In the adapical half of the ventral shell part, some vague and irregularly spaced radial lines are visible. The dorsal side of the shell is much flatter and has five radial ribs. The middle one of these is well separated from the lateral sets of two ribs, that lay close together and in some specimens merge almost completely. Lateral areas are slightly swollen. There is a prominent ridge all along the apertural margin in front of which an apertural lip is preserved in some specimens. The greatest width of the shell is above the lateral spines.

Material examined – Anda1, RGM 517 820 (1; Pl. 5, fig. 7), RGM 517 821 (1), RGM 517 822 (4 fragments), RGM 517 823 (15), RGM 517 824 (10 on slab of matrix; Fig. 8); Anda2, RGM 517 825 (1, 2 fragments), RGM 517 826 (1 cf.), RGM 517 827 (1); Anda3, RGM 517 828 (1 fragment); Anda5, RGM 517 829 (5 internal moulds); Anda6, RGM 517 830 (1, 2 fragments), RGM 517 831 (1); RGM 517 832 (9 fragments); AndaClif1, RGM 429 292 (2 fragments); AndaClif3, RGM 429 326 (7 fragments); Tiep2, RGM 517 833 (1, 4 fragments).

Discussion – Specimens of this large *Cavolinia* species are extremely fragile in the Pangasinan material, and, therefore, are predominantly represented by fragments and internal matrix moulds. Just a few specimens are somewhat better preserved. In one specimen (RGM 517 826) from locality Anda2, the apical spine is curved dorsally instead of almost straight, as in typical *C. tridentata*. The specimen has size and ornament of the present species, but because of its bent larval shell it has to be identified *Cavolinia* cf. *tridentata*.

In the Recent fauna this species has a somewhat patchy circumglobal distribution (van der Spoel, 1967, fig. 356; Bé & Gilmer, 1977, p. 785, fig. 27) between 65° N (in the Atlantic) and 50° S. The species is present all over the Mediterranean (type area), but apparently does not occur in the Caribbean and the Red Sea. This wide distribution underlies the existence of numerous forms described in the course of time. The specimens from Pangasinan agree to a large extent with the typical form, as illustrated by Rampal (1975, fig. 52M) and others.

From Japan, Shibata & Ishigaki (1981, fig. 5) recorded this species from Blow zone N17 (Tortonian/Messinian) onwards, but it should be checked if the older occurrences (up to and inclusive of Zanclean) do not belong to *Cavolinia grandis* (Bellardi, 1873). The latter species was demonstrated to predate *C. tridentata* in Mediterranean localities and in New Zealand (Janssen, 1995, 2000b, 2004). The occurrence of *C. grandis* in the Japanese Pliocene is acknowledged by Ujihara (1996, p. 783, as *Cavolinia rattonei* Simonelli, 1896 = *C. grandis*) from the lower part of the Miyazaki Group, Tsuma Member (Blow zones N18-20). The same author recorded *C. tridentata* only from the upper part of the Takanabe Member, which was supposed to represent the upper part of Blow zone N20. These data approach the observations in Europe and New Zealand closely.

***Cavolinia vendryesiana* (Guppy, 1873) forma *hyugaensis* Ujihara, 1996**
Pl. 6, fig. 1.

- . 1990 *Cavolinia* cf. *C. vendryesiana* (Guppy): Ujihara *et al.*, p. 321, pl. 2, figs. 13, 14.
- * 1996 *Cavolinia vendryesiana hyugaensis* new subspecies: Ujihara, p. 785, figs. 7.18-30.
- . 2004 *C. vendryesiana* f. *hyugaensis*: Janssen, p. 120.

Description – See Ujihara (1996). The present material convincingly shows the most important difference compared to other forms of *C. vendryesiana* (for a more general description and synonyms, see Janssen, 2004, p. 118), *viz.* the presence of a flattened area behind the horseshoe-shaped ridge on the dorsal shell part. Just as it is visible in some of the specimens illustrated by Ujihara, this flattened area sometimes develops as two faintly concave depressions, situated on both sides of the vertical midline and touching the lower edge of the ridge. The Japanese specimens, however, differ in proportions; their greatest width is situated above the lateral spines, whereas in the present material it is situated at the spines. Furthermore, the Japanese shells have a larger dorso-ventral diameter.

Material examined – Anda1, RGM 517 834 (3), RGM 517 835 (4, 23 fragments); Anda2, RGM 517 836 (5), RGM 517 837 (3, many fragments), RGM 517 838 (1; Pl. 6, fig. 1); Anda3, RGM 517 839 (2), RGM 517 840 (4, many fragments); Anda4, RGM 517 841 (3), RGM 517 842 (6, 18 fragments); Anda6, RGM 517 843 (2 fragments); AndaClif1, RGM 429 293 (4 fragments); AndaClif3, RGM 429,327 (1 fragment); Roxas, RGM 517 844 (4 fragments); Tiep2, RGM 517 845 (9, 14 fragments); Tiep4, RGM 517 846 (1); Tiep5, RGM 517 847 (1, 2 fragments).

Discussion – Janssen (2004, p. 118) discussed the various morphs of *Cavolinia vendryesiana*, concluding an infrasubspecific status for most of them. The observation that the Pangasinan material agrees with the forma *hyugaensis* in its most important characteristic, but differs in proportions, acknowledges the idea that such differences should not be considered to be of much taxonomical importance. According to Ujihara the Japanese material was collected from Blow zones N18-20 (Zanclean). It is a common species in the Takanabe Member, Miyazaki Group (Ujihara, 1996, table 1) with which the Pangasinan assemblages are correlated here (see the chapter on age assignment, below). (See p. 126.)

***Cavolinia ventricosa* (Guppy, 1882)**
Pl. 5, fig. 2.

- * 1882 *Hyalea ventricosa* n. sp. Guppy, p. 176, pl. 7, fig. 15.
- 1903 *Cavolinia ventricosa* Guppy: Dall, p. 1582.
- .v 1928 *Cavolinia ventricosa* (Guppy): Woodring, p. 114, pl. 1, figs. 8, 9.
- .v 1934 *Cavolinia ventricosa* (Guppy): Collins, p. 184, pl. 7, figs. 16-18.
- 1960 *Cavolinia* (*sic*) *ventricosa* (Guppy): Pchelintsev & Korobkov, p. 252, fig. 710.
- 1970 *Cavolina* (*Cavolina*) cf. *C. ventricosa* (Guppy): Woodring, p. 429, pl. 63, figs. 11, 12.
- 1982 *Cavolinia ventricosa* (Guppy): Bernasconi & Robba, pp. 217, 218.
- .v 1998 *Cavolinia ventricosa* (Guppy): Janssen, p. 102, pl. 2, figs. 4-8 (with lectotype designation).

Description – See Janssen (1998).

Material examined – AndaDeVos, RGM 517 848 (1 fragment; Pl. 5, fig. 2).

Discussion – This is the first record of this species from a Pacific locality. The single fragment collected at the AndaDeVos locality agrees completely with the dorsal shell part ornament configuration of the lectotype, as illustrated by Janssen (1998, pl. 2, fig. 7). The species is known from the Piacenzian of Bowden, Jamaica, and from two localities in Haiti (Port-au-Prince Beds). Bowden and Port-au-Prince for a long time were considered to be contemporaneous (e.g., Stainforth, 1948) and of Miocene age. Aubry (1993), Berggren (1993) and Janssen (1998) demonstrated the Middle Pliocene age of the Bowden Beds convincingly. Pteropod species recorded from Port-au-Prince by Collins (1934, pp. 157, 158, stations 9578 and 9654) agree with the Bowden shell beds faunas, leading to the conclusion that the Port-au-Prince Beds are coeval.

***Cavolinia* sp. 1**

Pl. 6, fig. 3.

Description – Just two fragments of the dorsal shell part were found. In both cases they show seven radial ribs of approximately the same width, the middle one just slightly wider than the others. Concentric growth lines are visible. Apical, apertural and ventral shell parts are missing.

Material examined – Anda6, RGM 517 849 (1; Pl. 6, fig. 3); RGM 517 850 (1 fragment).

Discussion – These two fragments cannot be related to any known cavoliniid species.

***Cavolinia* sp. 2**

Pl. 6, fig. 4.

Description – A single, poorly preserved specimen, is available. It is a somewhat indurated internal mould with shell remnants. Shell height is almost 4.0 mm, width 2.5 mm and dorsoventral diameter 1.5 mm. The dorsal shell part has five radial ribs, vaguely delimited, the central one wider and more separated from the two sets of lateral ribs. Dorsal apertural margin strongly overhanging the aperture. No distinctly separated apertural lip is present (or preserved). Lateral spines very weak. Ventral shell part most convex at half the shell height.

Material examined – Tiep1, RGM 517 852 (1; Pl. 6, fig. 4).

Discussion – This specimen does not agree with any of the other cavoliniids in the Pangasinan material and might represent an undescribed species.

Remarks – Fragmentary *Cavolinia*-material that cannot be identified to species level is available from most localities. Internal moulds and/or fragments from dorsal and/or ventral shell parts are in the collection (but not specified in Table 26) from Anda5, RGM

517 852 (5); AndaClif1, RGM 429 295 (many fragments); AndaClif3, RGM 429 331 (many fragments); AndaDeVos, RGM 517 853 (many fragments); Roxas, RGM 517 854 (12 fragments); Tiep1, RGM 517 855 (2); Tiep3, RGM 517 856 (12 fragments); Tiep5, RGM 517 857 (many fragments).

Apical shell parts: Anda1, RGM 517 858 (many); Anda2, RGM 517 859 (many); Anda3, RGM 517 860 (many); Anda4, RGM 517 861 (many); Anda6, RGM 517 862 (13); AndaClif1, RGM 429 296 (30); AndaClif3, RGM 429 332 (25); AndaDeVos, RGM 517 863 (many); Roxas, RGM 517 864 (15); Tiep2, RGM 517 865 (many); Tiep3, RGM 517 866 (9); Tiep4, RGM 517 867 (9); Tiep5, RGM 517 868 (14).

Genus *Diacavolinia* van der Spoel, 1987

Type species – *Diacavolinia longirostris* (de Blainville, 1821) (Recent).

Remarks – A completely different ontogeny of the initial shell parts induced van der Spoel (1987, p. 77) to the introduction of the genus *Diacavolinia*, a monotypic genus, with *Cavolinia longirostris* as type species. *Diacavolinia* species differ from all *Cavolinia* species by shedding of the larval shell and closing of the opening in the teleoconch by bending together the dorsal and ventral shell walls, without a septum being formed (so-called ‘closing joint’). In some of the *Diacavolinia*-species and also in the fossil species described below, however, a narrow septum is present. The development of larvae into fully grown individuals is described in detail by Bandel & Hemleben (1995).

‘*Cavolinia*’ *longirostris* for a very long time was considered a ‘good species’, in which just some subspecies and formae were accepted. Van der Spoel *et al.* (1993) restudied the *Diacavolinia longirostris* complex, raised six already existing infraspecific taxa to species level and introduced 18 new species (and two formae) in the genus *Diacavolinia*. All 24 species resemble each other to a large extent and it has yet to be demonstrated that they do merit specific status.

No fossil species have been described in this genus so far. The species present in the Pangasinan material does not agree with any of the described Recent taxa and is here introduced as a new species.

Diacavolinia pristina sp. nov.

Pl. 6, figs. 5, 6.

Holotype – RGM 517 873 (Pl. 6, fig. 5).

Type locality – Anda4, Cabarruyan Island (Pangasinan, Philippines), coastal cliff section at co-ordinates c. N 16° 17.413' E 119° 56.197', map-sheet 6975-I, Bolinao (Fig. 1).

Stratum typicum – Greyish-brown marlstone, in interbedded sandstone, siltstone and claystone, below Bolinao Limestone, Pliocene.

Derivatio nominis – From L. *pristinus* (adj.) = former, as this is the first fossil species in the genus *Diacavolinia*.

Paratypes – Anda1, RGM 517 869 (3 fragments), RGM 517 870 (1; Pl. 5, fig. 6); Anda2, RGM 517 871 (1, 10 fragments); Anda4, RGM 517 872 (8, 10 fragments); Roxas, RGM 517 874 (2 fragments).

Diagnosis – Small ($H = 2.56$ mm) *Diacavolinia* of triangular shape, lateral spines weakly developed, dorsal apertural lip overhanging the aperture, but snoutlike compression barely present, no outer hump.

Description – The shell is roughly triangular in shape. When the larval shell is shed, a slitlike joint of dorsal and ventral shell parts remains that in one specimen at least is closed with a narrow septum. Dorsal shell part rather convex, with a well-developed apertural lip, in some specimens as a weak snout, or rostrum; an outer hump is absent. There are five faintly developed radial ribs, the central one continuing into the rostrum, the two lateral ones ('lock ribs' of van der Spoel *et al.*, 1993) barely visible. Lateral spines straight and short. Ventral shell part more swollen, slightly wider than high and occupying 60 % of the shell's height. Very faint transverse ornament is present on the most convex part near the aperture. Two vague radial grooves are seen in floodlight, running from the caudal shell part into the direction of the closing mechanisms. The apertural margin of this shell part is slightly recurved and in some specimens slightly less high in its middle part.

Discussion – This species is smaller than all forms described by van der Spoel *et al.* (1993). The smallest Recent species is *Diacavolinia angulosa* (Gray, 1850), with a shell height ranging between 3.0 and 4.8 mm, which differs clearly by the presence of a well-developed outer hump and a distinctly separated rostrum (van der Spoel *et al.*, 1993, p. 143). Generally speaking it can be said that all the species described by van der Spoel *et al.* resemble each other more closely than *D. pristina*.

This is the first *Diacavolinia* species recorded as a fossil. Janssen (2004, p. 117) suggested that the specimen illustrated by Shibata (1984, pl. 7, fig. 4) as *Cavolinia longirostris* forma *angulosa* (Gray) could represent a *Diacavolinia* species, as Shibata wrote that the dorsal lip is rostrate and separated from the rest of the dorsal surface by a deep transverse groove. These characteristics, however, do not occur in the illustrated specimen and the description rather refers to material of Pleistocene age, published by Shibata & Ujihara (1983, p. 165, pl. 45, fig. 6) as *Cavolinia longirostris angulosa*, but even that specimen, considering the illustration, seems to be a real *Cavolinia*.

Genus *Diacria* Gray, 1847

Type species – *Diacria trispinosa* (de Blainville, 1821) (Recent).

Remarks – Species of this genus differ markedly from *Cavolinia*. *Diacria* has a straight or just slightly deviating larval shell with a clearly separated spherical or elliptical protoconch-1, whereas in *Cavolinia* the larval shell is curved and conical without a clearly separated protoconch-1. Furthermore the apertural margins in *Diacria* are reinforced by considerably thickened ridges. In *Cavolinia* and *Diacavolinia* the margins are not thickened, but recurved (ventral apertural lip) or developed into an apertural lip

or rostrum (dorsal shell part). A similar type of protoconch as in *Diacria* is seen in the Miocene genus *Diacrolinia* Janssen, 1995, in which, however, the apertural margins are more *Cavolinia*-like.

The samples studied for this paper yielded five species of *Diacria*. Three of these appeared to be undescribed and for a further one a new forma is introduced. Specimens retaining their protoconch were found of *D. italica* f. *fissicostata* and *D. paeninsula*. In *D. philippinensis* and presumably also in *D. microstriata* the protoconch is shed. The larval shell of *D. trispinosa* differs by its spherical protoconch-1 and could easily be recognised even if isolated. A further number of larval shells could not be identified with certainty and is included in the collection as *Diacria* sp. Some of these are illustrated herein (Pl. 25, figs. 4-6).

***Diacria italica* Grecchi, 1982 forma *fissicostata* f. nov.**

Pl. 7, figs. 1, 2; Pl. 8, fig. 7; Pl. 24, figs. 11, 12.

- . 1978 *Diacria* cf. *digitata* (Guppy): Grecchi, p. 112, fig. 5 (pars, non Guppy, non figs. 1-4, 6-10 = *D. italica sensu stricto*).
- v. 1982 *Diacria digitata* (Guppy) *italica* Grecchi ssp.n., p. 723, pl. 54, fig. 5 (pars, non Guppy, non figs. 1-4 = *D. italica sensu stricto*).

Holotype – RGM 517 875 (Pl. 7, fig. 1).

Type locality – Anda1, Cabarruyan Island (Pangasinan, Philippines), coastal cliff section at co-ordinates c. N 16° 17.413' E 119° 56.197', map-sheet 6975-I, Bolinao (Fig. 1).

Stratum typicum – Greyish-brown to yellowish-brown marlstone, below Bolinao Limestone Formation, Pliocene.

Derivatio nominis – From *L. fissum* - fissure, and *costa* - rib; *fissicostata* - with a divided rib.

Paratypes – Anda1, RGM 517 876 (3), RGM 517 877 (many fragments), RGM 517 878 (2 protoconchs), RGM 517 879 (1 protoconch; Pl. 8, fig. 7); Anda2, RGM 517 880 (9), RGM 517 881 (many fragments), RGM 517 882 (5 protoconchs), RGM 539 833 (1 protoconch; Pl. 24, fig. 11), RGM 539 834 (1 protoconch; Pl. 24, fig. 12); Anda3, RGM 517 883 (7, 16 fragments), RGM 517 884 (2 protoconchs); Anda4, RGM 517 885 (3, 5 fragments), RGM 517 886 (1; Pl. 7, fig. 2); Anda6, RGM 517 887 (4 fragments); AndaClif1, RGM 429 297 (4 fragments); AndaClif3, RGM 429 333 (2 fragments); AndaDeVos, RGM 517 888 (1, 6 fragments), RGM 517 889 (1 protoconch); Roxas, RGM 517 890 (6 fragments).

Two fragments from the Piacenzian of Campore (near Salsomaggiore, Parma, Italy; leg. L. Bertolaso, don. 1991) are in the Leiden collection (RGM 396 681). Two fragments from Volpedo, Ca' Barbieri (Italy, Alessandria) are in coll. G. Grecchi (Milano, Italy), one of them illustrated in Grecchi (1978, fig. 5).

Diagnosis – This new forma consistently differs from the typical species by the presence of a short fissure in the central rib on the dorsal shell part, close to the apertural margin.

Description – Shell lozenge-shaped, shell height (inclusive of protoconch) approximately 4.0 mm, shell width between the spines $3\frac{1}{4}$ mm, dorso-ventral diameter around 1.5 mm. Well-developed lateral spines at about mid-height (when complete). Dorsal shell part with three radial ribs in the centre part of the shell, separated by narrower interspaces. The middle rib over a short distance subdivided in two, close to the thickened apertural margin. The triangular lateral areas are slightly swollen, but not clearly developed into ribs, as seen, for example, in *Diacria trispinosa*. Ventral shell part swollen, considerably more convex than the dorsal one. Vaguely delimited radial ribs are visible in the adapical part and narrow radial lines occur close to the recurved apertural lip. Larval shell not shed, but usually broken, no closing septum is formed. Protoconch (Pl. 8, fig. 7) elliptical with a rounded tip, strongly resembling the protoconch of *Diacria philippinensis*, but with a slightly wider apical angle, larger dorso-ventral diameter and radial ornament on dorsal side of protoconch-2 starting earlier.

Discussion – Grecchi (1982) introduced the name *italica* as a subspecies of *Diacria digitata* (Guppy, 1882). The same author had described and illustrated this form earlier, but without naming it (Grecchi, 1975, p. 228, pl. 1, figs. 3-5; 1978, p. 111, pl. 1, figs. 1-10). Unfortunately, his 1978 photographs show much better preserved specimens than the one chosen as the holotype (Grecchi, 1982, pl. 54, fig. 1), in which the apertural shell parts are not preserved. Two incomplete specimens in his material (1978, fig. 5; 1982, fig. 5) show the characteristic so typical for all Pangasinan specimens; that is, a separation in two of the central radial rib on the dorsal side, close to the aperture. This feature was not mentioned by Grecchi. As is clear from the exclusive occurrence of this form in the present samples, this is not an incidental feature of the species. Contrary to the Philippine material it seems to occur only uncommonly in the Italian specimens.

Diagnostic characteristics for the distinction from *D. digitata*, referred to by Grecchi in his description of the subspecies *italica*, are lateral spines more conical and more developed, constriction near the dorsal lip stronger, and lateral margins and margins of the dorsal lip less wide. Grecchi compared his specimens with the illustrations of *D. digitata* in Collins (1934, pl. 11, figs. 1-9) and the differences can easily be seen by comparing the illustrations. Additional differences are the lower position of the considerably more weakly developed lateral spines that are commonly pointing downwards in *D. digitata*. These features are all acknowledged in the lectotype of *D. digitata* (designated Janssen, 1998, pl. 2, fig. 9a-d). For all these reasons the taxon *D. italica* is here considered to be an independent species.

The remaining question, however, is whether or not typical *D. italica* has a subdivided central rib on the dorsal side and that is not so easy to answer a question. The holotype of *D. italica*, curiously enough, is a poorly preserved specimen (seen in 1992 in the collections of the Università degli Studi di Milano, Sezione Geologia e Paleontologia, Milano, Italy, and reillustrated herein Pl. 6, fig. 7) in which the dorsal apertural part is missing. This specimen therefore does not give a clue. On the other hand, of all the illustrations given by Grecchi (1975, 1978, 1982), just two incomplete specimens show the split rib and the feature was not mentioned in Grecchi's descriptions. Therefore, the specimen illustrated by Grecchi (1978, figs. 8-10) is here considered to represent 'typical' *Diacria italica*.

Specimens from Japan (Blow zones 18-20) illustrated by Shibata (1980, pl. 3, fig. 18a-

c, as *Cavolinia digitata*) and Ujihara (1996, figs. 6/1-6, as *Diacria digitata* subsp. indet.) are here considered to represent the typical form of *D. italica*. The occurrence of typical *D. italica* as well as the form with the subdivided rib in the Pliocene of both the Mediterranean and the western Pacific indicates that the latter should be considered either a separate species or a forma. Because of the overlapping distributions and the only small distinguishing feature preference is given here to introduce it as a forma, *D. italica* f. *fissicostata*.

The Late Miocene *Diacria mbaensis* Ladd, 1934 (Janssen, 1999b, pl. 1, figs. 6, 7, pl. 2, figs. 13, 14) is a related species with a very similar shape of the protoconch, but differing from *D. italica* in having five radial ribs on the dorsal side, separated by narrower interspaces, less developed lateral spines and a considerably weaker constriction of the adapertural part of the dorsal side.

***Diacria microstriata* sp. nov.**

Pl. 8, fig. 1.

Holotype – RGM 517 891 (Pl. 8, fig. 1).

Type locality – AndaDeVos, Cabarruyan Island (Pangasinan, Philippines), coastal cliff section at co-ordinates N16° 17.413' E 119° 56.197', map-sheet 6975-I, Bolinao. Leg. J. de Vos, April 2000.

Stratum typicum – From interbedded marlstone, sandstone and claystone below Bolinao Limestone Formation, Pliocene.

Derivatio nominis – From Gr. μικρός (*mikros*) (adj.) - small, and L. *striatus* (adj.) - striate; *microstriata* = with fine striation.

Paratypes – Anda6, RGM 517 893 (3, 4 fragments); AndaDeVos, RGM 517 892 (1 fragment).

Diagnosis – An ovate *Diacria* unlike any of the known species, shell height approximately 4¼ mm. Greatest shell-width situated just above the middle. Lateral spines weakly developed, straight. Base of shell with very weak radial ornament. Ventral and dorsal shell parts with micro-ornament of longitudinal striation.

Description – Shell medium-sized (H approximately 4¼ mm), ovate, with distinctly separated dorsal and ventral shell parts. Apical spine absent in all specimens, probably shed, protoconch unknown (apical shell parts identified herein as *Diacria* sp. (Pl. 25, figs. 4-6) might belong to the present species). In the holotype the opening seems to be closed by a septum. Lateral spines weakly developed, straight. Distance between spines 65 % of shell width. Maximum shell width just above the horizontal midline. Dorsal shell part slightly convex. Surface smooth, apart from some vague radial element in the base of the shell (floodlight) that fade away rapidly adaperturally. Apertural margin thickened, especially at the places of the closing mechanism, where the dorsal shell part is slightly constricted. The upper two thirds has a micro-ornament of longitudinal stria-

tions, resembling the ornament in *Cuvierina (Urceolarica)* species (magnification 25 ×). This ornament is especially well visible at places where light reflects on the shell's surface. Growth lines are relatively distinct, at places they cause a slight undulation of the shell-wall. Ventral shell part more convex than dorsal one, with a straight and thickened apertural margin, slightly recurved outward, lower than the dorsal margin. Ornament of lowermost ventral shell part with barely visible radial elements. Micro-ornament as in dorsal shell part. Growth lines show a slight curvature in adapical direction close to the apertural margin.

Measurements - Four more or less complete specimens were measured (Table 20).

Discussion - Because of its thickened apertural margins and shed apical shell part, this species distinctly belongs in the genus *Diacria*, but it does not resemble any of the known species. The ovate shell form, the weak radial ornament and the presence of micro-ornament distinguish it from all other known taxa. Another *Diacria*, however, in the present material, described below as *D. paeninsula* sp. nov., has similar shape and ornament, but remains much smaller, lacks the micro-ornament and its larval shell is not shed.

Interesting is the occurrence of *Diacria microstriata* in just two samples (AndaDeVos and Anda6), in which *D. paeninsula* is absent. The precise location of sample AndaDeVos is unknown, but as it yielded the present species it might be taken at or near the Anda6 locality.

***Diacria paeninsula* sp. nov.**

Pl. 8, figs. 2-4.

Holotype - RGM 517 896 (Pl. 8, fig. 2).

Type locality - Anda2, Cabarruyan Island (Pangasinan, Philippines), coastal cliff section at co-ordinates c. N 16° 17.413' E 119° 56.197', map-sheet 6975-I, Bolinao (Fig. 1).

Stratum typicum - Greyish-brown to yellowish-brown marlstone, below Bolinao Limestone Formation, Pliocene.

Derivatio nominis - From *L. paeninsula*, named after the peninsula of Anda, at Cabarruyan Island.

Table 20. Measurements of four specimens of *Diacria microstriata* sp. nov.

	H	W	H/W-ratio	W of septum	dorso-ventral diameter
holotype	4.39	3.53	125	0.28	1.91
Anda6	4.36	3.57	122	0.22	1.99
	4.15	3.24+	128-	0.24	1.74
	4.23	3.57	119	0.32	-

Paratypes – Anda1, RGM 517 894 (1 fragment), RGM 517 895 (1, 16 fragments), RGM 517 956 (1 protoconch); Anda2, RGM 517 897 (2, 32 fragments), RGM 517957 (2 protoconchs); Anda3, RGM 517 898 (17 fragments), RGM 517 899 (1 protoconch; Pl. 8, fig. 4), RGM 517 958 (1 protoconch); AndaClif1, RGM 429 298 (10 protoconchs); Roxas, RGM 517 900 (1 fragment); Tiep3, RGM 517,901 (7 fragments), RGM 517 959 (2 protoconchs); Tiep 4, RGM 517 802 (1 fragment), RGM 517 960 (14 protoconchs), RGM 517 961 (1 protoconch; Pl. 8, fig. 3); Tiep5, RGM 517 903 (5 fragments), RGM 517 962 (2 protoconchs).

Diagnosis – Small *Diacria* species (H just over 2 mm) with broadly ovate shell and very weak dorsal ornament of five ribs, fading out adaperturally. Larval shell with elliptical protoconch-1, not shed. Lateral spines curved downward.

Description – Small *Diacria*-species (H approximately 2¼ mm) of broadly oval shape. Dorsal and ventral shell parts distinctly separated, the ventral one more convex. Dorso-ventral diameter half the shell width. Apical shell part with protoconch retained, protoconch-1 elliptical, protoconch-2 conical, separated by a faint constriction, with a carina and clear wrinkles at the sides. Lateral spines rather well-developed, pointing downwards. Distance between lateral spines 70 % of maximal shell width.

Dorsal shell part with a weak radial ornament of five ribs in the basal part, fading out towards the aperture. Middle rib narrow, lateral ribs twice as wide. Dorsal apertural margin thickened, hardly or not constricted where dorsal and ventral shell parts touch.

Ventral shell part less high than dorsal one, practically smooth, some radial elements are seen in floodlight. Ventral apertural margin almost straight, clearly thickened and slightly curved outward. Apart from the weak radial ornament and growth lines the surface of both sides is shiny, there is no micro-ornament.

Measurements – See Table 21 for measurements of the adult shell and Table 22 for protoconch measurements.

Table 21. Measurements of holotype and four paratypes of *Diacria paeninsula* sp. nov.

	H ratio	W spines	H/W- diameter	W between	dorso-ventral
holotype	2.44	1.76	139	1.24	0.84
Anda1	2.64	1.84	143	1.16	1.00
Anda2	2.64	1.96	135	1.40	-
-	-	-	-	1.32	-
-	2.60	-	-	1.40	-

Table 22. Measurements for four specimens of protoconch-1 of *Diacria paeninsula* sp. nov.

n = 4	H	W	dorso-ventral diameter
range	0.240-0.280	0.176-0.184	0.142-0.146
mean	0.265	0.180	0.143

Discussion – This species is not rare, but predominantly represented by fragments, the holotype being the only complete specimen. It is unlike any of the existing species of *Diacria*, but resembles somewhat the general shape of *D. microstriata* sp. nov., described above. It remains smaller, about half the size of that species, it has clearly downward-pointed lateral spines and no micro-ornament. Furthermore, the larval shell is retained, not shed. *Diacria paeninsula* was found at several localities, but is absent from the two samples that yielded *D. microstriata*.

***Diacria philippinensis* sp. nov.**

Pl. 7, fig. 3; Pl. 8, fig. 6; Pl. 25, fig. 1.

v. (2000a) *Diacria* aff. *mbaensis* (Ladd): Janssen, pp. 3, 4 (*non* Ladd).

Holotype – RGM 517 904 (Pl. 7, fig. 3).

Type locality – Anda1, Cabarruyan Island (Pangasinan, Philippines), coastal cliff section at co-ordinates c. N 16° 17.413' E 119° 56.197', map-sheet 6975-I, Bolinao (Fig. 1).

Stratum typicum – Greyish-brown to yellowish-brown marlstone, below Bolinao Limestone Formation, Pliocene.

Derivatio nominis – The species is named after the Republic of the Philippines (Republika ng Pilipinas, in Filipino language).

Paratypes – Anda1, RGM 517 905 (26), RGM 517 906 (many fragments), RGM 517 907 (2 protoconchs), RGM 517 930 (1 protoconch; Pl. 8, fig. 6), RGM 539 835 (1; Pl. 25, fig. 1); Anda2, RGM 517 908 (28), RGM 517 909 (many fragments), RGM 517 910 (16 protoconchs); Anda3, RGM 517 911 (25), RGM 517 912 (many fragments), RGM 517 913 (10 protoconchs); Anda4, RGM 517 914 (1), RGM 517 915 (14), RGM 517 916 (many fragments), RGM 517 917 (4 protoconchs); Anda6, RGM 517 918 (1), RGM 517 919 (5, many fragments); AndaClif1, RGM 429 299 (25 fragments); AndaClif3, RGM 429 334 (14 fragments), RGM 429 335 (1 protoconch); AndaDeVos, RGM 517 920 (7); RGM 517 921 (many fragments); Roxas, RGM 517 922 (10 fragments), RGM 517 923 (1 protoconch); Tiep1, RGM 517 924 (1); Tiep2, RGM 517 925 (7), RGM 517 926 (many fragments); Tiep3, RGM 517 927 (1, 12 fragments); Tiep 4, RGM 517 928 (2 fragments); Tiep 5, RGM 517 929 (2, 10 fragments).

Diagnosis – *Diacria* species of the *D. quadridentata* group, shell height approximately 2.5-3.0 mm. Greatest shell-width situated at the lateral spines. Strong dorsal ornament of five radial ribs. Transverse ornament of a variable number of distinct crests on dorsal side close to the apertural margin. Transverse striae on ventral shell part weak.

Description – Shell globose, slightly higher than wide. Ventral shell part far more convex than dorsal one, with strongest inflation just above the middle of the shell height (lateral view). The greatest width of the shell usually is at the rather well-developed lateral spines that are straight or slightly curved adapically. In a few specimens the dis-

tance between the spines is slightly less than the greatest width of the shell. Ventral apertural margin straight and curved outward. Ornament on ventral side close to the aperture weak, only visible in floodlight. Dorsal apertural margin thickened (particularly where dorsal and ventral sides are connected with a closing mechanism) and with some concentric furrows. A variable number (2-9; Pl. 25, fig. 1) of distinct transverse crests is present close to the dorsal apertural margin. Apical spine shed in all specimens, opening closed with a slightly convex or flat septum. Larval shell with an elliptical protoconch-1, protoconch-2 flat and slender (more so than in *D. italica* f. *fissicostata*), smooth, with lateral carinae.

Measurements – Measurements of 14 specimens are given in Table 23.

Discussion – In the first report on the Pangasinan material (Janssen, 2000a), fragments of this species were identified as *Diacria* aff. *mbaensis*. The abundant new material, however, in a much better state of preservation, demonstrates that it belongs to the group of Recent *Diacria quadridentata*, in which several infraspecific taxa used to be accepted (van der Spoel, 1971, 1976b).

A dichotome identification key in van der Spoel (1976, p. 50) leads to six formae of *D. quadridentata*. Van Leyen & van der Spoel (1982) raised most of these to species level. The following Recent species nowadays are recognised; *D. quadridentata* (de Blainville, 1821), *D. costata* Pfeffer, 1880, *D. danae* van der Spoel, 1968, *D. schmidti* van der Spoel, 1971, and *D. erythra* van der Spoel, 1971. In each of the two last named species, two subspecies are recognised. These are all characterised by a more or less globular form of the fully grown shell and a larval shell with elliptical protoconch-1 that is shed in adult specimens, the opening closed by a septum. The geographical distributions are sometimes very large (*D. danae*: tropical/subtropical, circumglobal), sometimes restricted (*D. erythra*: Red Sea, western Indian Ocean).

Comparing the measurements given in Table 23 with the data given by van Leyen & van der Spoel (1982, p. 109) for the Recent species shows that shell heights of the Pangasinan specimens agree reasonably well with the Recent *D. erythra* f. *erythra*, but other dimensions demonstrate considerable differences. For example, the data for 'width between lateral spines' differ strongly; in the measurements of van Leyen & van der Spoel these values are lower than 'shell width' for all species, whereas in the present material 'shell width' is practically identical with 'width between lateral spines'. In this respect *D. philippinensis* differs markedly from all Recent taxa.

Fossil material of this group has only been mentioned from the Quaternary, for example, Shibata & Ujihara (1983, p. 163, pl. 44, figs. 10, 11) refer to Middle and Late

Table 23. Measurements of holotype and 13 paratypes of *Diacria philippinensis* sp. nov. from locality Anda1.

	H	W	H/W-ratio	W of septum	dorso-ventral diameter
holotype	2.36	2.24	105	0.80	1.52
range	2.36-3.04	2.08-2.80	104-112	0.80-1.00	1.52-2.08
mean	2.56	2.40	108.8	0.86	1.72

Pleistocene specimens of *D. quadridentata erythra* from Japan. The present Pangasinan samples are the first records of a pre-Quaternary species of this group. The species is strikingly common in the samples, hundreds of specimens are found, albeit predominantly as fragments.

***Diacria trispinosa* (de Blainville, 1821) forma *bisulcata* Gabb, 1873**

Pl. 7, fig. 4; Pl. 8, fig. 5; Pl. 25, figs. 2, 3.

- v. 1873 *Diacria bisulcata*. Gabb n.s., p. 200.
- . 1882 *Diacria bisulcata* Gabb: Guppy, p. 175 (reprinted in Harris, 1921, p. 244).
- 1893 *Cavolinia (Diacria) bisulcata* Gabb: Dall, p. 430.
- v. 1922 *Diacria bisulcata* Gabb: Pilsbry, p. 309, fig. 4 (three figures).
- ? 1924 *Cavolina* sp. cf. *C. bisulcata* (Gabb): Woodring *et al.*, p. 164 (name only).
- . 1928 *Diacria bisulcata* Gabb: Woodring, p. 116, pl. 1, figs. 14, 15 (partim, material includes *Styliola subula*, see Collins, 1934, p. 199).
- . 1934 *Diacria bisulcata* Gabb: Collins, p. 197, pl. 9, figs. 18-20 (copied from Pilsbry, 1922) (partim, non pl. 9, figs. 13-17 and pl. 10, figs. 1-3 = *D. trispinosa sensu stricto*).
- 1972 *Diacria bisulcata* Gabb: Noda, p. 478, pl. 57, fig. 18.
- 1974 *Diacria* cf. *D. bisulcata* Gabb: Perrilliat, p. 35.
- 1979 *Diacria bisulcata* Gabb: Pavia & Robba, p. 564.
- 1984 *Diacria trispinosa* forma *trispinosa* (Blainville): Shibata, p. 84, pl. 25, figs. 1-3 (non forma *trispinosa*).
- . 1988 *Diacria piccola* Bleeker & van der Spoel new species, p. 60, figs. 2-4.
- v. 1995 *Diacria trispinosa* (de Blainville): Janssen, p. 107, pl. 9, figs. 3, 4 (excl. synonymy).
- v. 1998 *Diacria trispinosa* (de Blainville) forma *bisulcata* Gabb: Janssen, p. 104, pl. 2, fig. 14.
- v. 1999a *Diacria trispinosa* (de Blainville) forma *bisulcata* Gabb: Janssen, p. 26, pl. 5, figs. 7, 8.

Description – For a general description of *Diacria trispinosa*, see van der Spoel (1967, p. 84, fig. 76). The forma *bisulcata* differs from the typical form by merger of the three central radial ribs of the dorsal side into one wide rib. All specimens found in the Pangasinan samples belong to this form. In just a few specimens, using floodlight, a tripartition of the central rib is indicated.

Larval shells (Pl. 25, figs. 2, 3) of this species are easily distinguished from the other species of *Diacria* by the shape of the protoconch-1, which is spherical instead of elliptical in front view and dorso-ventrally compressed (Table 25). The sides of protoconch-2 are carinated by a doubled carina.

Measurements – Only few specimens are sufficiently complete to be measured. Lateral spines are commonly broken and the values for shell height are of little value as the apical spine breaks off at random. Results are given in Table 24. The specimen from locality Tiep2 is striking, being almost twice the size of other shells. Also further specimens, all damaged or fragmentary, from that site are larger than in the other samples. In all other respects, however, they agree with the bulk of the material. Measurements for protoconchs are given in Table 25. Measured were width, dorso-ventral diameter and height of protoconch-1 (from base to the constriction).

Material examined – Anda1, RGM 517 931 (6), RGM 517 932 (9), RGM 517 933 (1; Pl. 7, fig. 4), RGM 517 934 (many fragments), RGM 517 935 (1 protoconch; Pl. 8, fig. 5); Anda2, RGM 517 936 (7), RGM 517 937 (10), RGM 517 938 (many fragments), RGM 517

939 (4 protoconchs), RGM 539 836 (1 protoconch; Pl. 25, fig. 2), RGM 539 837 (1 protoconch; Pl. 25, fig. 3); Anda3, RGM 517 940 (4), RGM 517 941 (6, many fragments), RGM 517 942 (3 protoconchs); Anda4, RGM 517 943 (7), RGM 517 944 (1, many fragments), RGM 517 945 (5 protoconchs); Anda5, RGM 517 946 (4), RGM 517 947 (3); Anda6, RGM 517 948 (3), RGM 517 949 (2, 17 fragments); AndaClif1, RGM 429 300 (2, 3 fragments); AndaClif3, RGM 429 336 (8 fragments); AndaDeVos, RGM 517 950 (2, many fragments); Roxas, RGM 517 951 (17 fragments, 2 protoconchs); Tiep1, RGM 517 952 (2); Tiep 2, RGM 517 953 (7, many fragments); Tiep3, RGM 517 954 (3 fragments); Tiep5, RGM 517 955 (4 fragments, 4 protoconchs).

Discussion – In the discussion on forms of *D. trispinosa* (de Blainville), Janssen (2004, p. 120) did not refer to the paper of Bontes & van der Spoel (1998), in which *Diacria rubecula* Bontes & van der Spoel was introduced. These authors also gave a general discussion on the *D. trispinosa* group, inclusive of measurement ranges, a new interpretation of colour patterns and distribution maps, concluding on six Recent species and a further ‘subfossil’ species, *D. piccola* Bleeker & van der Spoel, 1988.

Janssen (2004) considered *D. piccola*, in spite of its small size, identical with *D. bisulcata* Gabb, 1873. In both taxa the dorsal side shows three radial ribs, instead of the usual five in typical *D. trispinosa*. The wide central rib apparently replaces the three central ribs of *D. trispinosa*. The specimen size obviously is not of any taxonomical value, as is also demonstrated by the measurements given in Table 24.

Diacria trispinosa forma *bisulcata* was recorded from the Late? Miocene to Early-Middle Pliocene of the Río Gurabo and Río Mao sections, Dominican Republic (Janssen, 1999), from the Piacenzian of Bowden, Jamaica (Collins, 1934; Janssen, 1998) and from the Italian Late Miocene-Pliocene (Janssen, 1995). Noda (1972) and Shibata (1984), among others, recorded occurrences of *D. bisulcata/trispinosa* in the Plio-Pleistocene of

Table 24. Measurements of eight fully grown specimens of *Diacria trispinosa* (de Blainville, 1821) forma *bisulcata* Gabb, 1873.

locality	W	H	H above spines	dorso-ventral diameter
Anda1	4.73	4.40	2.24	1.74
	4.48	4.32	2.24	1.49
	4.73	4.23+	2.32	1.66
Anda2	4.56	4.23	2.07	1.58
	4.73	4.40	2.24	1.58
	4.40	4.40	2.16	1.66
Anda3	4.73	4.15	2.07	1.58
Tiep2	8.22	8.22	4.15	2.82

Table 25. Measurements of protoconchs of *Diacria trispinosa* (de Blainville, 1821) forma *bisulcata* Gabb, 1873 from localities Anda1(1), Anda2 (3), Anda4 (5) and Tiep5 (1).

n = 10	W	H	dorso-ventral diameter
range	0.22-0.24	0.18-0.20	0.16-0.18
mean	0.231	0.189	0.165

Japan. In most of these cases the forma *bisulcata* co-occurs with typical *D. trispinosa*. In the present samples, however, typical *Diacria trispinosa* is virtually absent. The exclusive occurrence of f. *bisulcata* in the Pangasinan material might have taxonomical implications, as, for example, a higher rank of this taxon after all, but too few distributional data are available yet to jump to conclusions.

Family Sphaerocinidae Janssen & Maxwell in Janssen, 1995

Genus *Sphaerocina* Jung, 1971

Type species – *Sphaerocina formai* (Audenino, 1897) emend. Ferrero Mortara *et al.*, 1983 (Miocene).

***Sphaerocina convolvula* sp. nov.**

Pl. 8, fig. 8; Pl. 25, fig. 7.

Holotype – RGM 517 963 (Pl. 8, fig. 8).

Type locality – AndaDeVos, Cabarruyan Island (Pangasinan, Philippines), coastal cliff section at co-ordinates N 16° 17.413' E 119° 56.197', map-sheet 6975-I, Bolinao. Leg. J. de Vos, April 2000.

Stratum typicum – Interbedded marlstone, sandstone and claystone below Bolinao Limestone Formation, Pliocene.

Derivatio nominis – From L. *convolvere* (verb) - to roll up, *convolvula* = rolled up.

Paratypes – AndaDeVos, RGM 517 964 (1 fragment), RGM 539 841 (1; Pl. 25, fig. 7).

Diagnosis – *Sphaerocina* of one complete volution, with an irregularly spherical protoconch-1.

Description – Shell consisting of a dorsally and ventrally flattened tube, comprising just one whorl curved in a 360° spiral, regularly increasing in diameter, initial and proximal parts not touching. Protoconch-1 irregularly spherical, more or less pear-shaped, separated by a slight constriction. Aperture broken, but transversely elliptical. Growth lines very faint, slightly curved adaperturally.

Discussion – Although the type species of *Sphaerocina* was described already in 1897 (and ever since considered to be a representative of the Limacinidae family), the true morphological characteristics, inclusive of the larval shell part, were only revealed by Janssen & Maxwell (*in* Janssen, 1995). They considered *S. formai*, the only described species in that genus, to have evolved from a *Clio*-like predecessor. *Sphaerocina formai*, known from the Mediterranean, the Caribbean and New Zealand, occurred during the Middle Miocene (Langhian). Janssen (1995, p. 164; 2003, p. 20) furthermore referred to an undescribed species from the Late Oligocene of southwest France, with a different type of protoconch and to incompletely known material from the Aquitanian of Malta. The few specimens found in the present material differ in the

shape of the protoconch-1 clearly from *S. formai* (compare Janssen, 1995, pl. 13, figs. 9, 10), in which species the protoconch-1 is perfectly round. Fully grown specimens of this latter species are completely involute, and have about three whorls and very special apertural structures.

The Late Oligocene specimens from France show a curvature of 180° only and most probably represent an early evolutionary stage of *Sphaerocina*. Of that species sufficient specimens are available to eventually investigate the microstructure of the shell wall (helical or cross-lamellar), which might help to reveal the systematic position of *Sphaerocina*.

The new species described here shows a curvature of 360° and it might be that these are just juvenile specimens. No specimens or fragments were found, however, indicating that the species might have had more volutions when adult. The clearly broken aperture of both the holotype and the paratype indicate that the species has been a bit larger at least. The vertical range of *Sphaerocina* now includes Late Oligocene to Pliocene.

Suborder Pseudothecosomata Meisenheimer, 1905
Superfamily Cymbulioidea Gray, 1850
Family Cymbuliidae Gray, 1840

Cymbuliidae sp.

Pl. 25, fig. 8.

Description – Among abundant very juvenile limacinids, a few specimens were found that show a more rapidly widening last whorl. These resemble Cymbuliidae and could belong to one or more species of the genera *Cymbulia* or *Gleba*. The material (just four specimens), however, is too scarce and too juvenile for a better identification. One of the specimens, the most complete of those available, is represented here by SE micrograph.

Material examined – Anda3, RGM 539 842 (1; Pl. 25, fig. 8); AndaClif1, RGM 429 301 (3).

Discussion – Fossil Cymbuliidae have hardly ever been recorded. Even from the Recent species the shells are barely known. Good illustrations of embryonic shells of Recent *Gleba* are found in the unfortunately unpublished thesis of Kunz (1996, p. 156, pl. 27).

Family Peraclididae Tesch, 1913
Genus Peraclis Forbes, 1844 (emend. Pelseeneer, 1888)

Type species – *Peraclis reticulata* (d'Orbigny, 1836) (Recent).

***Peraclis reticulata* (d'Orbigny, 1836)**

Pl. 8, fig. 9.

1976b *Peraclis reticulata* (d'Orbigny): van der Spoel, p. 28, fig. 9 (with extensive synonymy).

Description – See van der Spoel (1976b).

Material examined – Anda1, RGM 517 965 (8, 1 fragment), RGM 517 966 (1; Pl. 8, fig. 9); Anda2, RGM 517 967 (15, 1 fragment); Anda3, RGM 517 968 (16); Anda4, RGM 517 969 (17); Anda6, RGM 517 970 (1); AndaClif1, RGM 429 302 (2 juveniles).

Discussion – Specimens from the Pangasinan material in general are small and usually poorly preserved because of their fragility. The largest available specimen reaches just over 1 mm only and has three whorls. They resemble compared juvenile Recent material to such an extent that they are considered to be identical. Recent specimens may reach a shell height of 6 mm and have five whorls. The main reason to consider the present specimens identical with *P. reticulata* (apart from the general shape of the shell) is the fact that the subsutural crests are very weakly developed, contrary to, for example, *P. bispinosa* Pelseneer, 1888, which has a similar shape, but strongly developed crests (compare Janssen, 2004, pl. 4, figs. 5-7).

Cainozoic occurrences of *Peraclis reticulata* are not known to date. From the Miocene of Poland the species *P. lata* (Krach, 1981) is known. Janssen (2004) recorded the bathypelagic species *P. bispinosa* and *P. triacantha* (Fischer, 1882) from the Middle Pliocene of Spain. Furthermore, material as yet unidentified is available (RGM collections) from the Mediterranean Early and Middle Miocene. One such specimen was illustrated in Janssen (2003, p. 20, pl. 4, fig. 15).

Order Gymnosomata

Gymnosomata sp.

Pl. 25, fig. 9.

Description – Very small embryonal shells with a height of approximately 0.25 mm. Protoconch-1 is globular, slightly higher than wide and dorso/ventrally a bit compressed. Protoconch-2 is separated by a deep constriction, in which numerous, very short vertical crests are seen (Pl. 25, fig. 9b). It is collar-shaped and a bit swollen without any surface ornament and changes suddenly into what might be an early teleoconch where growth-lines appear. This part of the shell is particularly compressed dorso-ventrally, resulting in an elliptical aperture.

Material examined – Anda1, RGM 539 843 (1; Pl. 25, fig. 9); Tiep2, RGM 539 844 (1).

Discussion – Identification of fossil Gymnosomata embryonic shells is virtually impossible yet, as long as such shells of most of the many Recent species are still unknown. Larval Gymnosomata shells are known from the Early Miocene onwards (Janssen, 2004; RGM collections) and obviously represent a number of species.

The very small Recent and/or Quaternary larval Gymnosomata shells have repeatedly been considered to represent embryonic shells of *Clio polita* (Pelseneer, 1888), by Almogi-Labin & Reiss (1977, p. 25, pl. 1, figs. 1-5), Morlotti & Torelli (1980, p. 124, pl. 1, fig. 12), Torelli & Buccheri (1983, p. 160ff, pl. 2, fig. 2), Buccheri & di Stefano (1984, p. 182ff, pl. 1, fig. 6) and Ivanova (1985, p. 341ff, pl. 2, fig. 8).

Excellent illustrations of the larval shell of *Paedocione doliiformis* Danforth, 1907, were published already by Lalli & Conover (1973, p. 12, figs. 4, 5; 1976, p. 237, figs. 1-6),

who also gave illustrations of the larval shell of two other gymnosomatous gastropods, viz. *Clione limacina* (Phipps, 1774) and *Pneumoderma atlanticum* (Oken, 1815). Van der Spoel & Diester-Haass (1976, p. 88, 2 figs.) illustrated quite similar, but specifically unidentified Quaternary gymnosomatous larval shells.

Van der Spoel (1976b, pp. 19, 20), however, listed far over 40 species of Recent Gymnosomata, all of which might have, and presumably have indeed, a calcareous initial shell. These do not necessarily resemble the few described forms, as indicated, for instance, by Kunz (1996, p. 170, pl. 32), who illustrated some unidentified, but strongly different, types of gymnosomatous larval shells. The few specimens recovered from the Pangasinan material agree quite well with specimens illustrated by Kunz (1996, pl. 32, figs. 1, 2) as 'Gymnosoma Typ I'. As Kunz's paper was not published, some of the illustrations are copied in a forthcoming paper (Janssen, 2007, p. 165, figs. 5-7).

Almogi-Labin (1984, p. 495) was the first to recognise that the records of *Clio polita* protoconchs in reality represent gymnosomatous pteropods and Grecchi (1987) corrected the *C. polita* identifications from the Mediterranean and the Red Sea to *Paedoclione doliiformis*. This, however, is a subarctic species, in the adult stage exclusively known from the northwest Atlantic. Thus, it seems improbable that Mediterranean finds belong to this species. Grecchi & Bertolotti (1988, p. 117, pl. 7, figs. 16, 17) also illustrated *P. doliiformis*, but indicated another presumed gymnosomatous shell erroneously as *Cuvierina* cf. *columnella* (Rang, 1827). This latter, to date unidentified species, was also illustrated by Kunz (1996, pl. 32, fig. 4) as 'Gymnosoma Typ II'.

Age assignment and palaeoenvironment

General characteristics of the Pangasinan assemblages – From the fifteen samples analysed for the present paper, an unprecedented number of no less than 50 fossil holoplanktonic molluscan species is recorded (Tables 25, 26). Differences between the individual samples are small and for a large part can be explained by sample size or preservation. Sample Anda5, for example, yielded few species, as the sedimentary rock at that locality is decalcified and just a few of the larger species could be collected as internal moulds. In some cases, however, small, but distinct, differences exist, as for the species *Clio convexa*/*C. pyramidata* and for *Diacria microstriata*/*D. paeninsula*, as discussed above. Such differences rather reflect small changes in the overall planktonic assemblages at the time of deposition and cannot be interpreted as differences in age. Considering the general resemblance of the sample compositions it is assumed that they are all of similar age, representing a relatively short time interval. As said in the introduction, the samples from Anda could not be related to any vertical height difference in the exposed sections. The samples from Tiep were taken from an interval of some 80 m, but even in the case of samples Tiep1 and Tiep5 there is no considerable difference in species composition. The list of species quite surprisingly demonstrates the presence of no less than fifteen as yet undescribed taxa, which is 30 % of the total number present and a very clear indication of how poorly Pliocene holoplanktonic molluscan assemblages in this part of the world are known to date.

Furthermore, another striking feature is the occurrence in this material of quite a number of specimens that could with some certainty be related to Recent species, species that had hardly or not been recorded yet as fossils older than 'Quaternary' (e.g.,

Table 26. Numbers of specimens per sampling locality; m = many; f = fragment(s); j = juvenile(s); p = protoconch(s)

	Anda1	Anda2	Anda3	Anda4	Anda5	Anda6
<i>Atlanta cf. echinogyra</i>	4
<i>Atlanta fusca</i>	12	10	5	13	..	18
<i>Atlanta lesueuri</i>	3	2, 5j	25	7	..	1
<i>Atlanta lingayanensis</i>	3	3	2	5	..	1
<i>Atlanta oligogyra</i>	6	8
<i>Atlanta peroni</i>	m	m	m	3	..	10
<i>Atlanta plana</i>	..	2	1
<i>Atlanta richteri</i>	1, 1j	2, 2j	3, 9j	3, 9j
<i>Atlanta seapyi</i>	1	..	2j
<i>Atlanta tokiokai</i>	1	m	m	m	..	1
<i>Atlanta sp. indet.</i>	11	m	8	m	1	2, 5f
<i>Oxygyrus keraudreni</i>	m	m	m	m	..	3
<i>Protatlanta rotundata</i>	1, 8j	3, 5j	2, 7j	3j	..	1, 2j
<i>Protatlanta souleyeti</i>	33	26	m	m
(without spirals on protoconch)	3j	1	..	7
<i>Carinaria cf. lamarcki</i>	1f	1, 3f	1, 1f
<i>Carinaria sp.</i>	10	11	23	9
<i>Pterosoma cf. planum</i>	21	21	19	7	..	1
<i>Janthina (Janthina) prolongata</i>	1	1j
<i>Heliconoides inflata</i>	m	m	m	m	..	45
<i>Heliconoides sondaari</i>	62	53	m	m	..	22
<i>Limacina bulimoides</i>	m	m	m	m	..	22
<i>Striolimacina andaensis</i>	36	20	m	m	..	3
<i>Limacinidae sp.?</i>	1	2	1	1
<i>Creseis chierchiaie</i>	3	5, 3p	19	51, 1p
<i>Creseis clava</i>	m	m	m	m	..	10
<i>Hyalocylis marginata</i>	2
without thickened margin	3f	1	1j	1, 3j, 2f	..	1, 2j, 1f
<i>Styliola subula</i>	m	m	m	m	13	m
<i>Cuvierina (Urceolarica) urceolaris</i>	28, 17f, 1p	44	26	20, 3p	..	14 1p
<i>Clio (Balantium) cf. hataii</i>	1
<i>Clio (Bellardiclio) cuspidata</i>	3, 17f, 7p	33, 11f, 4p	8f, 4p	1, 16f, 4p	..	2f
<i>Clio (Clio) convexa convexa</i>	m	m	m	8j	..	6j
<i>Clio (Clio) pyramidata f. lanceolata</i>	3f, 9p	3, 3f, 12p	10p	m	1	4, 12f, 4p
<i>Cavolinia baniensis</i>	..	3
<i>Cavolinia landaui</i>	m	m	12, 7f	4, mf	..	2f
<i>Cavolinia perparvula</i>	3f	5, 3f	5, 10f	26, 40f	..	1, 11f
<i>Cavolinia shibatai</i>	8, 13f	11, mf	5, 5f	13, 8f	..	1
<i>Cavolinia tridentata</i>	27, 4f	3, 2f	1f	..	5	2, 11f
<i>Cavolinia vendryesiana f. hyugaensis</i>	7, 23f	9, mf	6, mf	8, 18f	..	2f
<i>Cavolinia ventricosa</i>
<i>Cavolinia sp. 1</i>	2f
<i>Cavolinia sp. 2</i>
<i>Cavolinia sp. indet.</i>	5	..
<i>Cavolinia sp. indet., apical shell parts</i>	mp	mp	mp	mp	..	13p
<i>Diacavolinia pristina</i>	1, 3f	1, 10f	..	9, 10f

AndaClif1	AndaClif3	AndaDeVos	Roxas	Tiep1	Tiep2	Tiep3	Tiep4	Tiep5
..	..	3
..	4	..	1j	..	2	3	4	5
..	1	1	2j	1	..
..	9	1	3	..	2
..	2	..	2
12j	3j	8	1, 4j	..	4	..	3j	..
2	1, 2j	..	7j
5j	5j	..	1j	4j	1j	3, 10j
..	1j	3, 3j	.. 6j
25j	..	1	1	3j	2j
1, 7f	10f	13	7f	5f	14f
23	17	..	5	5	19	7	7	8
3j	8j	..	1j	5j	7j	6j
mj	13j	4	2j	..	2	2, 18j	6j	31j
..
..
6	3	..	8	4	3	5
6	8	1	7	1	9	2	7	..
..
mj	m	m	30, 3f	8	m	m	45	m
15j	24j	20	8	10	12	19	8	40
40j	20j	10	20	19	4, mf	25	9	m
1	25	48	2	m
4	1
6p	1p	..	2	10	6	6
21	8	..	35	..	8	35	15	40
..	1f	20f	1f	..	6f
1j	3j, 8f	1j, 2f	6j, 17f	7f	..	3j, 8f
mj	m	m	m	m	m	50	25	28
..	9f	8f	1f	2	2	1p
..
1p	9f	5f	1p	1f	2f
38,4f	..	5j	23j	1j	5f	20j	4j	29j
1p	23f,6p	14f,8p	1p	10	1,1f	3p	2f	2p
..	..	1,9f	2f	..	11,13f
..	2,13f	2,16f	6f	..	5f	2f
1,1f	8f	5,5f	7f
..	2f	2f	2f	..	9,mf	5f	1,1f	2f
2f	7f	1,4f
4f	1f	..	4f	..	9,14f	..	1	1,2f
..	..	1f
..
..	1
mf	mf	mf	12f	2	..	12f	..	mf
30p	25p	mp	15p	..	mp	9p	9p	14p
..	2f

Table 26. Cont.

	Anda1	Anda2	Anda3	Anda4	Anda5	Anda6
<i>Diacria italica</i> f. <i>fissicostata</i>	4,mf,3p	9,mf,5p	7,16f,2p	4,5f	..	4f
<i>Diacria microstriata</i>	3,4f
<i>Diacria paeninsula</i>	1,17f,1p	3,32f,29	17f,2p
<i>Diacria philippinensis</i>	27,mf,3p	28,mf,16p	25,mf,10p	15,mf,4p	..	6,mf
<i>Diacria trispinosa</i> f. <i>bisulcata</i>	16,mf,1p	17,mf,4p	10,mf,3p	8,mf,5p	7	5,17f
<i>Sphaerocina convolvula</i>
Cymbuliidae sp.
<i>Peraclis reticulata</i>	9,1f	15,1f	16	17	..	1
Gymnosomata sp.						
	Anda1	Anda2	Anda3	Anda4	Anda5	Anda6

from ocean bottom samples). This is especially true for a number of Heteropoda, namely for the Atlantidae, a group notorious for its identification problems, even for Recent material. The present material demonstrates what could be expected; even species that are to date exclusively known from extant faunas have a fossil history. The lack of information on fossil Atlantidae up to now no doubt is caused by a combination of factors, among which the fragility of the specimens and identification problems may have contributed considerably.

Age of the Pangasinan assemblages and palaeoenvironment – The known vertical ranges of the species in the Pangasinan faunas are given in Table 27. The assemblages are specified per locality in Table 26.

From Tables 26/27 the following conclusions can be drawn:

1. Typically Zanclean (or older) species, such as *Clio braidensis* (Bellardi, 1873), *Cavolinia mexicana* (Collins, 1934) or *C. grandis* (Bellardi, 1873), are absent.
2. The species *Protatlanta rotundata* is known to occur already in the Miocene and ranges until and inclusive of the Piacenzian.
3. *Cavolinia shibatai* occurs during Zanclean and Piacenzian.
4. *Cavolinia landaui*, *C. ventricosa* and *Diacria italica* f. *fissicostata* are exclusively known from Piacenzian age.
5. *Atlanta plana*, *Clio cuspidata* and *Cavolinia tridentata* are only known from the Piacenzian and/or younger.
6. Considering points 1 to 5 a Piacenzian age of the Pangasinan assemblages must be concluded. This is in good agreement with results on planktonic Foraminifera by Dr Willem Jan Zachariasse (Faculty of Geosciences, Utrecht University, the Netherlands) (in litt., 2005). In sample Anda6 he found the following species: *Sphaeroidinella dehiscentes* (Parker & Jones, 1865), *Globigerinoides fistulosus* (Schubert, 1910), *Gnoides ruber* (d'Orbigny, 1839), *Gnoides conglobatus* (Brady, 1879), *Globorotalia menardii* (Parker, Jones & Brady, 1865), *Gtalia tumida* (Brady, 1877), *Gtalia crassaformis* (Galloway & Wissler, 1927), *Gtalia multicamerata* Cushman & Jarvis 1930 (with 7, sometimes 8 chambers in the ultimate whorl), and *Pulleniatina primalis* Banner & Blow, 1967.

Using the paper of Bolli & Saunders (1985) leads to an age of late Early to early Middle Pliocene, because of the overlap of *Globorotalia multicamerata* and *Globigeri-*

AndaClif1	AndaClif3	AndaDeVos	Roxas	Tiep1	Tiep2	Tiep3	Tiep4	Tiep5
4f	2f	1,6f,1p	6f
..	..	1,1f
10p	1f	7f,2p	1f,15p	5f,2p
25f	14f,1p	7,mf	10f,1p	1	7,mf	1,12f	2f	2,10f
2,3f	8f	2,mf	17f,2p	2	7,mf	3f	..	4f,4p
..	..	1,1f
3
2j
AndaClif1	AndaClif3	AndaDeVos	Roxas	Tiep1	Tiep2	Tiep3	Tiep4	Tiep5

noides fistulosus, agreeing with Blow zones N19-N20. According to Berggren *et al.* (1995), the following numeric ages would apply: LAD *Globorotalia multcamerata* 3.09 Ma and FAD *fistulosus* 3.33 Ma. On the new geologic time scale (Gradstein *et al.*, 2004) these ages agree with early Piacenzian.

7. A number of species (predominantly Heteropoda) hitherto only known from Quaternary and/or Recent assemblages occurred already during the Pliocene, *viz.* *Atlanta cf. echinogyra*(?), *A. fusca*, *A. lesueuri*, *A. oligogyra*, *A. peroni*, *A. tokiokai*, *Protatlanta souleyeti*, *Carinaria cf. lamarcki*(?), *Pterosoma cf. plana*(?), *Janthina (Janthina) prologata* and *Peraclis reticulata*.
8. Bathypelagic species, such as *Thielea helicoides* (Jeffreys, 1877), *Clio andreae* (Boas, 1886), *Peraclis bispinosa* Pelseneer, 1888, and/or *P. triacantha* (Fischer, 1882) were not found. As far as known all species have an epi- to upper mesopelagic distribution. Additional observations (rather fine-grained sedimentary rock, abundance of planktonic Foraminifera and benthic molluscs indicative for 'deeper' water) lead to an estimate of the sea depth of probably some 200-300 m.

Comparison with Japanese holoplanktonic assemblages – Fossil holoplanktonic Mollusca from the western Pacific realm are only known from Japan and southern Australia. Some data on Late Miocene holoplanktonics are furthermore known from the Fiji Islands (Ladd, 1934; Janssen, 1999b). Oligo-Miocene assemblages from South Australia were recorded by Janssen (1990). The only western Pacific area with information on Pliocene holoplanktonic molluscs is Japan. From the Indonesian archipelago hardly any faunas have been described to date and it may be expected that specific research in that large area will reveal their existence, as demonstrated, for instance, by the assemblage from the Late Miocene asphaltic deposits of Buton, Sulawesi (Janssen, 1999b).

From Japan quite a number of Miocene to Quaternary assemblages were recorded in many publications and it seems very useful to make comparisons with the Japanese occurrences. As the present Pangasinan material has no resemblance whatsoever with Miocene faunas a restriction is made here for Japanese papers on Late Cainozoic (Pliocene and younger) assemblages.

Noda (1972), in one of the first Japanese papers entirely devoted to holoplanktonic molluscs, described a small assemblage of just eight species from several localities in

Okinawa. The age of this material was indicated as being Miocene and Pliocene, but later (Ujihara, 1996) the age was restricted to Blow zones N 18-20 (Zanclean). It seems, however, that the age even is somewhat younger, considering the common occurrence of '*Cavolinia telemus* Linnaeus' (= *C. tridentata*), to date only known to occur above the Zanclean/Piacenzian boundary.

Shibata (1979) studied Late Pliocene/Early Pleistocene material from many localities in the Shizuoka Prefecture, Japan. He found three heteropod and seven pteropod species, all of which (as far as identified) representing extant taxa. Material illustrated therein (pl. 19, figs. 25-28), however, identified *Cavolinia longirostris longirostris* (Lesueur) from 'loc. 16' = Tonbe, Nango Alternation Member (N 21 (Piacenzian), according to Ujihara, 1996); this belongs to one of the new species, *C. shibatai*, described in the present paper.

Shibata & Ishigaki (1981, fig. 5) found three Atlantidae (two of which were unidentified) in Cainozoic deposits of the Chubu Province, Japan. The oldest unidentified occurrence is in Blow zone N9 (Langhian/Serravallian), another in N 19-22 (Zanclean or younger). *Atlanta lesueurii*, finally, was only found in N 22 (Late Pliocene-Pleistocene). For the pteropods they list a clearly Miocene (Blow zone N 8-9) assemblage, with species such as *Clio bellardii* Audenino, 1897, *C. pedemontana* Mayer, 1868, and *Vaginella depressa* Daudin, 1800. From N 17 upwards they mention only extant species, with the exception of '*Cavolinia digitata*' (= *Diacria italica*?) from N 21 (Piacenzian).

Shibata & Ujihara (1983) studied Middle and Late Pleistocene assemblages from Japan, and recorded seven Atlantidae species, just two of which (*Atlanta peroni* and *Protatlanta souleyeti*) are also present in the Pangasinan material. Furthermore, they found 22 pteropod taxa, all belonging to still extant species.

Shibata *et al.* (1986) recognised a number of distinctly Miocene species recorded from Blow zones 10-13 in the Yamanashi Prefecture, Japan. For the interval N 19-22 they recorded nine species, all pteropods. Three of these are extinct species. *Clio balantium* f. *kakegawaensis* Shibata might be identical with *C. hataii* (see systematic part in the present paper), occurring during the Pliocene and Early Pleistocene. The specimen indicated as *Clio guidottii* Simonelli (pl. 7, fig. 10) indeed resembles that species and its occurrence in zone N 19 (Zanclean) agrees with the type locality of that species. But the reference (p. 43, tab. 1) of *Cavolinia bisulcata* Kittl, 1886 (= *Diacrolinia aurita* (Bellardi, 1873)) in zone N 19 must be erroneous, as that species is restricted to the Middle Miocene (Langhian).

This latter species (as *Cavolinia audeninoi* Vinassa de Regny, 1898), though, is also recorded for zones N 17-19 by Shibata (1986, p. 124, fig. 3). As it co-occurs in zone N 17 with *Diacria sangiorgii* Scarsella, 1934, a species restricted to Tortonian-Messinian, it presumably concerns the species *Diacrolinia elioi* Janssen, 1995 (synonym *Cavolinia itoigawai* Ujihara, 1996), which in the Mediterranean (Janssen, 1995) does not occur younger than Tortonian. Its co-occurrence in Japan with species such as *C. mexicana* (Collins, 1934) and *C. rattonei* Simonelli, 1896 (= *C. grandis* Bellardi, 1873) seems to point to a longer existence (Zanclean) of that species in the western Pacific.

Ujihara *et al.* (1990, p. 311, table 2) recorded 13 taxa from the N 19-20 interval (Zanclean) in the Japanese Sagara Group, four species of which are still extant. *Clio hataii* *kakegawaensis* might be identical with *C. cf. hataii*, as described above from locality Anda3. *Cuvierina cf. tubulata* Collins might be identical with either *C. ludbrookii* (Caprotti, 1962) or *C. jagti* Janssen, 1995, depending on the absence or presence of micro-orna-

ment, respectively. Considering the age, *C. ludbrooki* is the more probable possibility. *Cuvierina* sp. 1 (Ujihara *et al.*, 1990, pl. 1, fig. 8) is a very slender species and most probably undescribed. *Cavolinia* cf. *angusticostata* (Blanckenhorn, 1901) is identical with *C. grandis* (synonym *C. rattonei*), a species restricted to Zanclean. The illustrations of *C. cf. floridana* (Collins), *C. cf. gypсорum* (Bellardi) and *C. mexicana* (Collins) represent specimens that are too poorly preserved to be certain of their identification. *Cavolinia* cf. *vendryesiana* (Guppy), reidentified as *C. vendryesiana hyugaensis* by Ujihara (1996), is also present in the Pangasinan material. Forms of *C. vendryesiana* are known to occur from the Late Miocene (Tortonian-Messinian; Janssen, 1999b) to the Middle Pliocene (Piacenzian).

The most interesting Japanese paper for a comparison with the Pangasinan faunas is Ujihara (1996), in which pteropods from Pliocene localities in the Miyazaki Prefecture, numbered 1 to 44 in stratigraphical order, are recorded. The age of these, on the basis of planktonic Foraminifera, ranges between Blow zones N 18-20. In table 1 (p. 772-773), Ujihara specified the species per locality. A total of 24 taxa is mentioned, seven of which (29 %) belong to extant species. Several of the species found by Ujihara occur all over the section, but others have a restricted distribution.

The lower part of the sequence described by Ujihara (1996) has clear Late Miocene affinities by the presence of *Cavolinia itoigawai* (= *Diacrolinia elioi*) and forms related to *Cavolinia gypсорum*; they have a Tortonian, respectively Tortonian-Messinian distribution in the Mediterranean. A possible boundary between Messinian and Zanclean is difficult to indicate in this section, as there is an overlap of index species, with either Messinian species continuing into the Zanclean or species hitherto only known from the Zanclean starting already during the Late Miocene.

Other species from the lower part, however, indicate the Zanclean. *Clio shibatai* Ujihara, 1996, obviously is a local form of the Mediterranean *C. braidensis*, of Zanclean age. *Cavolinia rattonei* (= *C. grandis*) also points to a Zanclean age and it developed into the species *C. tridentata* around the Zanclean/Piacenzian boundary, which in the Japanese section should be situated somewhere around Ujihara's samples 39- 40, that is, the boundary between the Sadowara and Takanabe members. From the eleven species mentioned from localities 41-44 only *Clio kakegawaensis* Shibata, 1984 (maybe identical or closely related to *C. hataii*) and *Hyalocylis striata* (Rang, 1828) are absent from the Pangasinan samples. *Hyalocylis striata*, however, is easily mistaken for the new species *H. marginata*, if incompletely preserved material is available. In summary, the Pangasinan assemblages agree very well with localities 41-44 from the Ujihara (1996) section (= the Takanabe Member), but yielded far more species.

Acknowledgements

For guidance, company and assistance during the fieldwork the author is most grateful to Drs Willem Renema (NNM), †Paul Y. Sondaar and John de Vos (NNM). Mrs Edith Janssen-Kruit (Xewkija, Malta) assisted wonderfully during the fieldwork, bravely resisting high tides, tropical temperatures and aggressive insect attacks. Mr Frank P. Wesselingh (NNM) recognised the abundance of holoplanktonic molluscs in the first samples, brought them to the authors attention, helped in organising and financing the 2001 fieldwork, gave opinions on the benthic molluscan assemblages and

critically read the manuscript. Mr Charles P. Barnard (NNM) took care of sample processing. Mrs A. Bavelaar-Dekker (NNM library) helped in providing literature. The author is grateful to Drs Angel Bautista and Gina de Vera (National Museum of the Philippines, at Manila and Bolinao, respectively), as well as to their colleagues, for transportation facilities, their generous hospitality and help, and for permits to export the collected material.

Dr Rüdiger Bieler (The Field Museum of Natural History, Chicago, U.S.A.) gave his opinion on architectonic protoconchs. Dr Edmund Gittenberger (NNM) helped interpreting ICZN rulings. Dr Glauco Grecchi (Milano, Italy) supplied information on Italian *Diacria*-occurrences. Dr Ronald Janssen (SMF) allowed (sometimes long term) loans of Recent mollusc material for comparison. Mr Pierre Lozouet (MNHN) was kind enough to make the photographs of Figure 7 and gave information on lectotypes in his care. Professor Elio Robba (Università degli Studi di Milano, Sezione Geologia e Paleontologia, Milano, Italy) allowed me (already in 1992) to study pteropod collections in his care. Professor Roger R. Seapy (California State University, Fullerton, California, USA) gave his much appreciated opinion on Heteropoda identifications and critically read (earlier parts of) the manuscript. Dr Willem Jan Zachariasse (Faculty of Geosciences, Utrecht University, The Netherlands) studied one of the samples for planktonic Foraminifera and gave his opinion on its age.

Dr Cees van den Berg, Messrs Frank P. Wesselingh and Jeroen Goud (all NNM) instructed the author on how to produce acceptable SEM-images and/or on the composition of the plates. Dr John W.M. Jagt (Venlo, The Netherlands) improved the English language. Professors Klaus Bandel (Paläontologisches Institut und Museum, Universität Hamburg, Hamburg, Germany) and Roger Seapy kindly reviewed the present manuscript and improved it with numerous suggestions. The 2001 field work for this project was made possible by financial support of the Alida M. Buitendijk Fonds and the Stichting Jan Joost ter Pelkwijk-Fonds (Leiden, The Netherlands).

References

- Abildgaard, P.C. 1791. Nyere Efterretning om det Skaldyr fra Middelhavet, som Forskål har beskrevet under Navn af *Anomia tridentata*. *Skrivter Naturhistorie-Selskabet, Kiøbenhavn*, **1**: 171-175.
- Almogi-Labin, A. 1982. Stratigraphic and paleoceanographic significance of Late Quaternary pteropods from deep-sea cores in the Gulf of Aqaba (Elat) and northernmost Red Sea. *Marine Micropaleontology*, **7**: 53-72.
- Almogi-Labin, A. 1984. Population dynamics of planktic Foraminifera and Pteropoda, Gulf of Aqaba, Red Sea. *Proceedings Koninklijke Nederlandse Akademie van Wetenschappen*, **B87**: 481-511.
- Almogi-Labin, A. & Reiss, Z. 1977. Quaternary pteropods from Israel, 1. Holocene and Pleistocene pteropods from the Mediterranean continental shelf and slope of Israel, 2. Pteropods from Recent sediments in the Gulf of Elat. *Revista Española de Micropaleontología*, **9**: 5-48.
- Aubry, M.P. 1993. Calcareous nannofossil stratigraphy of the Neogene formations of eastern Jamaica. In: Wright, R.M. & Robinson, E. (eds), *Biostratigraphy of Jamaica. Geological Society of America Memoirs*, **182**: 131-178.
- Audenino, L. 1897. Pteropodi miocenici del Monte dei Cappucini in Torino. *Bullettino della Società Malacologica Italiana*, **20**: 97-114. [Also cited as 1895 or 1899.]
- Avnimelech, M. 1945. Revision of fossil Pteropoda from southern Anatolia, Syria and Palestine. *Journal of Paleontology*, **19**: 637-647.
- Bandel, K. & Hemleben, C. 1987. Jurassic heteropods and their modern counterparts (planktonic Gastro-

- podata, Mollusca). *Neues Jahrbuch für Geologie und Paläontologie, Abhandlungen*, **174**: 1-22.
- Bandel, K. & Hemleben, C. 1995. Observations on the ontogeny of thecosomatous pteropods (holoplanktic Gastropoda) in the southern Red Sea and Bermuda. *Marine Biology*, **124**: 225-243.
- Bandel, K., Riedel, F. & Weikert, H. 1997. Planktonic gastropod larvae from the Red Sea: a synopsis. *Ophelia*, **47**: 151-202.
- Banner, F.T. & Blow, W.H. 1967. The origin, evolution, and taxonomy of the foraminiferal genus *Pulleniatina* Cushman, 1927. *Micropaleontology*, **13**: 142-143.
- Batten, R.L. & Dumont, M.P. 1976. Shell ultrastructure of the Atlantidae (Heteropoda, Mesogastropoda) *Oxygyrus* and *Protatlanta*, with comments on *Atlanta inclinata*. *Bulletin of the American Museum of Natural History*, **157**: 265-310.
- Bé, A.W.H. & Gilmer, R.W. 1977. A zoogeographic and taxonomic review of euthecosomatous Pteropoda. In: Ramsay, A.T.S. (ed.), *Oceanic Micropaleontology*, **1**: 733-807. Academic Press, London.
- Bellardi, L. 1873. I molluschi dei terreni terziari del Piemonte e della Liguria, 1. Cephalopoda, Pteropoda, Heteropoda, Gastropoda (Muricidae et Tritonidae). *Memorie delle Reale Accademia delle Scienze di Torino (series 2)*, **27**: 1-264
- Bellini, R. 1905. Les ptéropodes des terrains tertiaires en quaternaires d'Italie. *Annales de la Société royale zoologique et malacologique de Belgique*, **40**: 23-45.
- Benson, W.H. 1835. Account of *Oxygyrus*; a new genus of pelagian shells allied to the genus *Atlanta* of Lesueur, with a note on some other pelagian shells lately taken on board the ship Malcolm. *Journal of the Asiatic Society of Bengal*, **4**: 173-176 [Not seen.]
- Berggren, W.A. 1993. Neogene planktonic foraminiferal biostratigraphy of eastern Jamaica. In: Wright, R.M. & Robinson, E. (eds), *Biostratigraphy of Jamaica. Geological Society of America Memoirs*, **182**: 179-217.
- Berggren, W.A., Hilgen, F.J., Langereis, C.G., Kent, D.V., Obradovich, J.D., Raffi, I., Raymo, M.E. & Shackleton, N.J. 1995. Late Neogene chronology: new perspectives in high-resolution stratigraphy. *Geological Society of America Bulletin*, **107**: 1272-1287.
- Bernasconi, M.P. & Robba, E. 1982. The thecosomatous pteropods: a contribution towards the Cenozoic Tethyan paleobiogeography. *Bollettino della Società Paleontologica Italiana*, **21**: 211-222.
- Bianco, S. Lo. 1888. Notizie biologiche riguardanti specialmente il periodo di maturità sessuale degli animali del Golfo di Napoli. *Mittheilungen aus der Zoologischen Station zu Neapel*, **8**: 385-440.
- Biekart, J.W. 1989. Euthecosomatous pteropods as paleohydrological and paleoecological indicators in a Tyrrhenian deep-sea core. *Palaeogeography, Palaeoclimatology, Palaeoecology*, **71**: 205-224.
- Blainville, H.M.D. de. 1818. Conchyliologie. *Dictionnaire des Sciences Naturelles*, **10**: 168-225.
- Blainville, [H.M.D.] de. 1821. Hyale, *Hyaloea* (Malacoz.). *Dictionnaire des Sciences naturelles*, **22**: 65-83.
- [Blainville, H.M.D.] de. 1822. Janthine, *Janthina*. *Dictionnaire des Sciences naturelles*, **24**: 148-155.
- Blainville, [H.M.D.] de. 1824. Mollusques. *Dictionnaire des Sciences naturelles*, **32**: 1-392.
- Blanc-Vernet, L., Chamley, H. & Froget, C. 1969. Analyse paléoclimatique d'une carotte de Méditerranée nord-occidentale. Comparaison entre les résultats de trois études: foraminifères, ptéropodes, fraction sédimentaire issue du continent. *Palaeogeography, Palaeoclimatology, Palaeoecology*, **6**: 215-235.
- Blanckenhorn, M. 1889. Pteropodenreste aus der oberen Kreide nord-syriens und aus dem hessischen Oligocän. *Zeitschrift der geologischen Gesellschaft*, **61**: 593-602.
- Blanckenhorn, M. 1901. Neues zur Geologie und Palaeontologie Aegyptens, 4. Das Pliocän- und Quartärzeitalter in Aegypten ausschliesslich des Rothen Meergebietes. *Zeitschrift der Deutschen geologischen Gesellschaft*, **53**: 307-502
- Bleeker, J. & Spoel, S. van der. 1988. *Diacria piccola* and *Diacria maculata*: two new pteropod mollusc species from the Atlantic and Pacific oceans. *Proceedings of the Biological Society of Washington*, **101**: 60-66.
- Boas, J.E.V. 1886. Spolia atlantica. Bidrag til pteropodernes. Morfologi og Systematik samt til Kundskaben om deres geografiske Udbredelse. *Videnskabernes Selskabs Skrifter*, **6** (naturvidenskabelig og mathematisk Afdeling), **4**: 1-231.
- Bolli, H.M. & Saunders, J.B., 1985. Oligocene to Holocene low latitude planktic foraminifera. In: Bolli, H.M., Saunders, J.B. & Perch-Nielsen, K. (eds), *Plankton Stratigraphy*: 228-301. Cambridge University Press, Cambridge.
- Bonnevie, K. 1913 (reprinted 1933). Pteropoda from the Michael Sars North-Atlantic deep-sea expedi-

- tion. *Report on the Scientific Results of the 'Michael Sars' North Atlantic Deep-Sea Expedition*, 3: 1-69.
- Bontes, B. & Spoel, S. van der. 1998. Variation in the *Diacria trispinosa* group, new interpretation of colour patterns and description of *D. rubecula* n. sp. (Pteropoda). *Bulletin Zoologisch Museum, Universiteit van Amsterdam*, 16 (11): 77-84.
- Bosc, L.A.G. 1802 (= an x). *Histoire naturelle des coquilles, contenant leur description, les moeurs des animaux qui les habitent et leurs usagers*, 2. Deterville, Paris: 330 pp.
- Bosc, [L.A.G.]. 1817. Limacine. *Nouveau Dictionnaire d'Histoire naturelle*, 18: 42.
- Brady, H.B. 1877. Supplementary note on the foraminifera of the Chalk (?) of the New Britain Group. *Geological Magazine*, 4: 534-546.
- Brady, H.B. 1879. Notes on some of the reticularian rhizopoda of the "Challenger" expedition, 1. On new or little-known arenaceous types. *Quarterly Journal of Microscopic Sciences* (new series), 19: 20-63.
- Buccheri, G. 1978. Pteropoda Euthecosomata ed Heteropoda (Mollusca, Gastropoda) in sedimenti batiali pleistocenici della East Yucatan Scarp (Mar dei Caraibi). *Bollettino della Società Paleontologica Italiana*, 17: 118-141.
- Buccheri, G. 1984. Pteropods as climatic indicators in Quaternary sequences: a Lower-Middle Pleistocene sequence outcropping in Cava Puleo (Ficarazzi, Palermo, Sicilia). *Palaeogeography, Palaeoclimatology, Palaeoecology*, 45: 75-86.
- Buccheri, G. 1985. Osservazioni paleoclimatiche al limite Pleistocene inferiore-Pleistocene medio della foce del Belice (Sicilia sud-occidentale) mediante l'uso degli pteropodi. *Bollettino della Società Geologica Italiana*, 104: 115-122.
- Buccheri, G. & Bertoldo, M. 1992. Le associazioni a pteropodi del Pleistocene mediterraneo, 2. Analisi paleoclimatica della carote nn. 1, 2 e 3 del Pozzo DSDP 132 (Leg 13). *Bollettino della Società Geologica Italiana*, 111: 493-511.
- Buccheri, G., Catalano, R. & Heezen, B. 1980. Pleistocene pteropod limestones dredged from the East Yucatan Scarp. *Palaeogeography, Palaeoclimatology, Palaeoecology*, 30: 97-105.
- Buccheri, G., Russo, B. & Bertoldo, M. 1994. Stratigrafia e paleoclimatologia della carota GN82-C41 (Mar Tirreno): foraminiferi e pteropodi. *Bollettino della Società Geologica Italiana*, 113: 127-155.
- Buccheri, G. & Stefano, E. di. 1984. Contributo allo studio del Golfo di Pozzuoli. Pteropodi e nanoplancton calcareo contenuti in tre carote: considerazioni ambientali e biostratigrafiche. *Memorie della Società Geologica Italiana*, 27: 181-193.
- Buccheri, G. & Torelli, L. 1981. Stratigraphy and paleoclimatic evaluations of the cores BS77-15 and BS77-33 (Sardinia basin, western Tyrrhenian Sea) by means of pteropod assemblages. *Ateneo Parmense, Acta Naturalia*, 17: 73-94.
- Burmeister, H. 1837. *Handbuch der Naturgeschichte*, 2. Zoologie: i-xii + 369-858. Enslin, Berlin.
- Cantraine, F. 1841. Malacologie méditerranéenne et litorale, ou description des mollusques qui vivent dans la Méditerranée ou sur le continent de l'Italie, ainsi que des coquilles qui se trouvent dans les terrains tertiaires italiens, avec des observations sur leur anatomie, leurs moeurs, leur analogie et leur gisement. Ouvrage servant de faune malacologique italienne et de complément à la Conchiologia fossile subapennina de Brocchi. *Mémoires de l'Académie royale de Bruxelles*, 13: 173 pp.
- Caprotti, E. 1962. Altri scafopodi piacentini di Castell'Arquato. *Atti della Società Italiana di Scienze Naturali di Milano*, 101: 93-101.
- Chen, C. & Bé, A.W.H. 1964. Seasonal distribution of euthecosomatous pteropods in the surface waters of five stations in the western North Atlantic. *Bulletin of Marine Science of the Gulf and Caribbean*, 14: 185-220.
- Children, J.G. 1823. Lamarck's genera of shells. *Quarterly Journal of Science, Literature, and the Arts*, 15: 216-258.
- Colantoni, P., Padovani, A. & Tampieri, R. 1970. Ricerche geologiche preliminari nel Mar Tirreno. Crociera CST 68 del Laboratorio di Geologia Marina del CNR-Bologna, 11. Molluschi. *Giornale di Geologia*, 37: 163-188.
- Collins, R.L. 1934. A monograph of the American Tertiary pteropod mollusks. *Johns Hopkins University Studies in Geology*, 11: 137-234
- Cossmann, M. 1888. Catalogue illustré des coquilles fossiles de l'Éocène des environs de Paris, faisant

- suite aux travaux paléontologiques de G.-P. Deshayes, 4. *Annales de la Société royale malacologique de Belgique*, 24: 3-381.
- Cox, L.R. 1960. Thoughts on the classification of the Gastropoda. *Proceedings of the Malacological Society of London*, 33: 239-261.
- Crosse, H. 1896. Note sur le genre *Pterosoma* de Lesson. *Journal de Conchyliologie*, 44: 207-212.
- Curry, D. 1982. Ptéropodes éocènes de la tuilerie de Gan (Pyrénées-Atlantiques) et de quelques autres localités du SW de la France. *Cahiers de Micropaléontologie*, 4 (for 1981): 35-44.
- Cushman, J.A. & Jarvis, P.W. 1930. Miocene Foraminifera from Buff Bay, Jamaica. *Journal of Paleontology*, 4: 353-368.
- Cuvier, G.[L.C.F.D.], 1797. *Tableau élémentaire de l'histoire naturelle des animaux*. Baudouin, Paris: 710 pp.
- Dall, W.H. 1889. A preliminary catalogue of the shell-bearing marine mollusks and brachiopods of the south-eastern coast of the United States, with illustrations of many of the species. *Bulletin of the United States National Museum*, 37: 3-221.
- Dall, W.H. 1893. Contributions to the Tertiary fauna of Florida, with especial reference to the Miocene silex-beds of Tampa and the Pliocene beds of the Caloosahatchie River, 2. Streptodonts and other gastropods, concluded. *Transactions of the Wagner Free Institute of Science of Philadelphia*, 3 (for 1892): 201-473.
- Dall, W.H. 1903. Contributions to the Tertiary fauna of Florida, with especial reference to the Miocene silex-beds of Tampa and the Pliocene beds of the Caloosahatchie River, including in many cases a complete revision of the generic groups treated of and their American Tertiary species, 6. Concluding the work. *Transactions of the Wagner Free Institute of Science of Philadelphia*, 3: 1219-1654.
- Dance, S.P. 1986. *A History of Shell Collecting*. Backhuys, Leiden: xv + 265 pp.
- Danforth, C.H., with introduction by Kingsley, J.S. 1907. A new pteropod from New England. *Proceedings of the Boston Society of Natural History*, 32: 1-19.
- Daudin, [F.M.]. 1800 (an 9 de la République). Nouveau genre de ver à tube calcaire, voisin des serpules et des dentales. *Bulletin des Sciences par la Société Philomatique* (series 2), 43: 145.
- Dieni, I. 1990. *Brunonia annulata* (Yokoyama, 1890) (Carinariidae, Mesogastropoda) nel Cretaceo inferiore della Sardegna. *Bollettino della Società Paleontologica Italiana*, 29: 43-51.
- Ehrmann, P. 1933. Mollusca. In: Brohmer, P., Ehrmann P. & Ulmer G. (eds), *Die Tierwelt mittel-europas*, 2: 1-264. Quelle & Meyer, Leipzig.
- Eschscholtz, F. 1829. *Zoologischer Atlas, enthaltend Abbildungen und Beschreibungen neuer Thierarten, während des Flottcapitains von Kotzebue zweiter Reise um die Welt, auf der Russisch-Kaiserlichen Kriegsschiff Predpriaetië in den Jahren 1823-1826 beobachtet*, 3. G. Reimer, Berlin: 18 pp.
- Faber, M.J. 2004. Marine gastropods from the ABC Islands and other localities, 5. A note on the distribution of *Oxygyrus keraudrenii* (Lesueur, 1817) (Gastropoda, Atlantidae). *Miscellanea Malacologica*, 1: 72.
- Ferrero Mortara, E., Montefameglio, L., Pavia G. & R. Tampieri. 1983. *Cataloghi VI. Catalogo dei tipi e degli esemplari figurati della collezione Bellardi e Sacco*, 1. Museo regionale di Scienze Naturali, Torino: 327 pp.
- Fischer, P. 1882. Diagnoses d'espèces nouvelles de mollusques recueillis dans la cours des expéditions scientifiques de l'avisole le Travailleur (1880 et 1881). *Journal de Conchyliologie*, 30: 49-53.
- Fol, H. 1875. Études sur le développement des mollusques, premier mémoire. Sur le développement des ptéropodes. *Archives de Zoologie Expérimentale et Générale, Paris*, 4: 214 pp.
- Forbes, E., 1844. Report on the Mollusca and Radiata of the Aegean Sea, and on their distribution, considered as bearing on geology. In: *Report of the Thirteenth Meeting of the British Association for the Advancement of Science, held at Cork in August 1843*: 131-193.
- Frontier, S. 1963. Présence de *Creseis chierchiai* (Boas) dans l'Océan Indien. *Cahiers ORSTOM, Océanographie*, 2: 229-232.
- Frontier, S. 1965. Le problème des *Creseis*. *Cahiers ORSTOM, Océanographie*, 3: 11-17.
- Frontier, S. 1966. Notes morphologiques sur les *Atlanta* récoltées dans le plancton de Nosy-Bé (Madagascar). *Cahiers ORSTOM, Océanographie*, 4: 131-135.
- Gabb, W.M., 1873. On the topography and geology of Santo Domingo. *Transactions of the American Philosophical Society* (new series), 15: 49-259.
- Galloway, J.J. & Wissler, S.G. 1927. Pleistocene Foraminifera from the Lomita Quarry, Palos Verdes Hills,

- California. *Journal of Paleontology*, **1**: 35-87.
- Geronimo, I. di. 1974. Molluschi pelagici in livelli di marne mioceniche presso Vetto (R. Emilia). *Conchiglie*, **10**: 181-192.
- Gittenberger, E. & Janssen, A.W. (eds). 1998. *De Nederlandse zoetwatermollusken. Recente en fossiele weekdieren uit zoet- en brakwater. Nederlandse Fauna 2*. Nationaal Natuurhistorisch Museum Naturalis, KNNV Uitgeverij & EIS-Nederland, Leiden: 288 pp.
- Golikov, A.N. & Starobogatov, Ya.I. 1975. Systematics of prosobranch gastropods. *Malacologia*, **15**: 185-232.
- Gougerot, L. & Braillon, J. 1965. Découverte d'une nouvelle espèce d'*Atlanta* (hétéropode) dans le Bartonien de Barisseuse (Oise). *Bulletin de la Société Géologique de France* (série 7), **7**: 302.
- Gradstein, F.M., Ogg, J.G. & Smith, A. 2004. *A Geologic Time Scale*. Cambridge University Press, New York: 610 pp.
- Gray, J.E. 1840. Shells of molluscos animals. In: *Synopsis of the contents of the British Museum*: 106-156. G. Woodfall, London.
- Gray, J.E. 1847. A list of the genera of recent Mollusca, their synonyma and types. *Proceedings of the Zoological Society of London*, **15**: 129-219.
- Gray, J.E. 1850. *Catalogue of the Mollusca in the collection of the British Museum, 2. Pteropoda*. British Museum and E. Newman, London: iv + 45 pp.
- Gray, J.E. 1853. On the division of ctenobrancheous gasteropodous Mollusca into larger groups and families. *Annals and Magazine of Natural History* (series 2), **11**: 124-132.
- Grecchi, G. 1975. Ritrovamento di *Cavolinia uncinata* (Rang, 1829) negli affioramenti di Castell'Arquato. *Conchiglie*, **11**: 93-96.
- Grecchi, G. 1978. Segnalazione di *Diacria* cfr. *digitata* (Guppy), nel Pliocene piemontese-emiliano. *Conchiglie*, **14**: 111-116.
- Grecchi, G. 1982. Pteropodi pliocenici dell'Italia settentrionale. *Rivista Italiana di Paleontologia*, **87**: 703-738.
- Grecchi, G. 1984. Molluschi planctonici e bentonici in sedimenti sapropelitici del Quaternario della dorsale Mediterranea. *Bollettino Malacologico*, **20**: 1-34.
- Grecchi, G. 1987. Revisione tassonomica degli esemplari fossili e subfossili di *Clio polita* rinvenuti in Mediterraneo e in Mar Rosso. *Bollettino Malacologico*, **23**: 297-303.
- Grecchi, G. & Bertolotti, M. 1988. Interpretazione paleoclimatica della carota CG18-BAN82 basata sull'analisi di Thecosomata Euthecosomata del Quaternario del Mediterraneo orientale. *Bollettino del Museo Regionale di Scienze Naturali, Torino*, **6**: 73-132.
- Guppy, R.J.L., 1882. On the Recent and Tertiary species of *Leda* and *Nucula* found in the Westindies: with notices of Westindian shells. *Proceedings of the Scientific Association of Trinidad* (series 2), **4**: 168-180. [Reprinted in Harris, 1921.]
- Harris, G.D. 1921. A reprint of the more inaccessible paleontological writings of Robert John Lechmore Guppy. *Bulletins of American Paleontology*, **8**: 1-198.
- Herman, Y., 1971. Vertical and horizontal distribution of pteropods in Quaternary sequences. In: Funnell, B.M. & Riedel, W.R. (eds), *Micropaleontology of Oceans*: 463-486. Cambridge University Press, Cambridge.
- Herman, Y. 1971. Quaternary climate changes in the eastern Mediterranean as recorded by pteropods and planctonic Foraminifera. In: Farinacci, A. (ed.), *Second International Plankton Conference, Proceedings*: 611-622. Tecno-Scienza, Roma.
- Herman, Y. 1981. Paleoclimatic and paleohydrologic record of Mediterranean deep-sea cores based on pteropods, planktonic and benthonic foraminifers. *Revista Española de Micropaleontología*, **13**: 171-200.
- Herman, Y. & Rosenberg, P.E. 1971. Pteropods as sea level indicators. In: Ters, M. (ed.), *Études sur le Quaternaire dans le monde*, **1**: 187-190. VIII Congrès INQUA, Paris 1969.
- International Commission on Zoological Nomenclature. 1999. *International Code of Zoological Nomenclature*. Fourth edition: xxix + 306 pp. The International Trust for Zoological Nomenclature, London.
- Ivanova, E.V. 1985. Late Quaternary biostratigraphy and paleotemperatures of the Red Sea and the Gulf

- of Aden based on planktonic Foraminifera and pteropods. *Marine Micropaleontology*, **9**: 335-364.
- Janssen, A.W. 1984. *Mollusken uit het Mioceen van Winterswijk-Miste. Een inventarisatie, met beschrijvingen en afbeeldingen van alle aangetroffen soorten*. K.N.N.V., N.G.V. & R.G.M., Amsterdam: 451 pp.
- Janssen, A.W. 1990. Pteropoda (Gastropoda, Euthecosomata) from the Australian Cainozoic. *Scripta Geologica*, **91**: 1-76.
- Janssen, A.W. 1995 Systematic revision of holoplanktonic Mollusca in the collections of the 'Dipartimento di Scienze della Terra' at Torino, Italy. *Museo regionale di Scienze naturali, Torino, Monografie*, **17**: 1-233
- Janssen, A.W. 1998. Holoplanktonic Mollusca (Gastropoda: Heteropoda and Thecosomata) from the Pliocene Bowden Beds, Jamaica. *Contributions to Tertiary and Quaternary Geology*, **35**: 95-111.
- Janssen, A.W. 1999a. Neogene paleontology in the northern Dominican Republic, 20. Holoplanktonic mollusks (Gastropoda: Heteropoda and Thecosomata). *Bulletins of American Paleontology*, **358**: 5-40.
- Janssen, A.W. 1999b. Euthecosomatous gastropods (Mollusca: Heterobranchia) from Buton (SE Sulawesi, Indonesia), with notes on species from Viti Levu, Fiji; systematics, biostratigraphy. *Geologie & Mijnbouw*, **78**: 179-189.
- Janssen, A.W. 2000a. *Report on two samples of holoplanktonic Mollusca from the Pliocene of Cabarruyan Island (Philippines)*. Nationaal Natuurhistorisch Museum, Department of Palaeontology, Leiden, Unpublished Internal Report, **156**: 1-8.
- Janssen, A.W. 2000b. Notes on the systematics, morphology and biostratigraphy of fossil holoplanktonic Mollusca, 7-9. 7. *Clio lucai* spec. nov. from the Plio/Pleistocene of northern Italy, with notes on evolutionary lineages of the genus *Clio*; 8. *Cavolinia grandis* (Bellardi, 1873) from the Early Pliocene of New Zealand, a further example of long-distance correlation by means of pteropods; 9. Apertural reinforcements in *Limacina atypica* (Laws, 1944) from the Miocene of New Zealand. *Basteria*, **64**: 35-50.
- Janssen, A.W. 2003. Notes on the systematics, morphology and biostratigraphy of fossil holoplanktonic Mollusca, 13. Considerations on a subdivision of Thecosomata, with the emphasis on genus group classification of Limacinidae. *Cainozoic Research*, **2**: 163-170.
- Janssen, A.W. 2004. Holoplanktonic molluscan assemblages from the Pliocene of Estepona (Spain, Málaga). *Palaeontos*, **5**: 103-131.
- Janssen, A.W. 2005. Development of Cuvierinidae (Mollusca, Euthecosomata, Cavoliniidae) during the Cainozoic: a non-cladistic approach with a re-interpretation of Recent taxa. *Basteria*, **69**: 25-72.
- Janssen, A.W. 2006. Notes on the systematics, morphology and biostratigraphy of fossil holoplanktonic Mollusca, 16. Some additional notes and amendments on Cuvierinidae and on classification of Thecosomata (Mollusca, Euthecosomata). *Basteria*, **70**: 67-70.
- Janssen, A.W. 2007. Holoplanktonic Mollusca (Gastropoda) from the Gulf of Aqaba, Red Sea and Gulf of Aden (Late Holocene-Recent). *The Veliger*, **49**: 140-195.
- Janssen, A.W. & de Vogel, E.F. 1965. *Zoetwatermollusken van Nederland*. Nederlandse Jeugdbond voor Natuurstudie, Amsterdam: 160 pp.
- Jeffreys, J.G. 1869. *British conchology, or an account of the Mollusca which now inhabit the British Isles and the surrounding seas*, 5. *Marine shells and naked Mollusca to the end of the Gastropoda, the Pteropoda, and Cephalopoda; with a supplement and other matter, concluding the work*. Van Voorst, London: 258 pp.
- Jeffreys, J.G. 1877. New and peculiar Mollusca of the Eulimidae and other families of Gastropoda, as well as of the Pteropoda, procured in the 'Valorous' expedition. *Annals and Magazine of Natural History* (series 4), **19**: 317-339.
- Johnson, C.W. 1934. List of marine Mollusca of the Atlantic coast from Labrador to Texas. *Proceedings of the Boston Society of Natural History*, **40**: 1-204.
- Jung, P. 1971. Fossil mollusks from Carriacou, West Indies. *Bulletins of American Paleontology*, **61**: 147-262.
- Jung, P. 1973. Pleistocene pteropods - Leg 15, site 147, Deep Sea Drilling Project. *Initial Reports Deep Sea Drilling Project*, **15**: 753-767.
- Kase, T. 1988. Reinterpretation of *Brunonia annulata* (Yokoyama) as an Early Cretaceous carinariid mesogastropod (Mollusca). *Journal of Paleontology*, **62**: 766-771.
- Kittl, E. 1886. Über die miozänen Pteropoden von Oesterreich-Ungarn, mit Berücksichtigung verwandter

- Vorkommnisse der Nachbarländer. *Annalen des Naturhistorischen Hofmuseums*, **1**: 47-74.
- Krach, W. 1981. Slimaki skrzydlonogi (Pteropoda) w Miocenie Polski i ich znaczenie stratygraficzne (The pteropods in the Miocene of Poland and their stratigraphic significance). *Prace Geologiczne*, **121**: 116-140. [In Polish with English summary.]
- Kunz, A. 1996. *Schalenmorphologische Merkmale der Ontogenesestadien ausgewählter Pteropoden (Gastropoda: Heterostropha)*. Unpublished Diplom-Arbeit, Universität Hamburg (Geologie-Paläontologie): vi + 196 pp.
- Ladd, H.S. 1934. Geology of Viti Levu, Fiji. *Bernice P. Bishop Museum Bulletin*, **119**: iii + 263 pp.
- Lalli, C.M. & Conover, R.J. 1973. Reproduction and development of *Paedocione doliiformis*, and a comparison with *Clione limacina* (Opisthobranchia, Gymnosomata). *Marine Biology*, **19**: 13-22.
- Lalli, C.M. & Conover, R.J. 1976. Microstructure of the veliger shells of gymnosomatous pteropods (Gastropoda: Opisthobranchia). *Veliger*, **18**: 237-240.
- Lalli, C.M. & Gilmer, R.W. 1989. *Pelagic Snails. The Biology of Holoplanktonic Gastropod Mollusks*. Stanford University Press, Stanford, California: viii + 259 pp.
- Lamarck, J.B.P.A. de]. 1801 (an 9). *Système des animaux sans vertèbres, ou tableau général des classes, des ordres et des genres de ces animaux; présentant leurs caractères essentiels et leur distribution, d'après la considération de leurs rapports naturels et de leur organisation, et suivant l'arrangement établi dans les galeries du Muséum d'Hist. Naturelle, parmi leurs dépouilles conservées; précédé du discours d'ouverture du Cours de Zoologie, donné dans le Muséum National d'Histoire Naturelle l'an 8 de la République*. Lamarck & Deterville, Paris: viii + 432 pp.
- Lamarck, J.B.P.A. de. 1812. *Extrait du cours de zoologie du Muséum d'Histoire naturelle sur les animaux sans vertèbres (mollusques, hétéropodes)*. D'Hautel el Gabon, Paris: 127 pp.
- Laursen, D. 1953. The genus *Ianthina*, a monograph. *Dana Report*, **38**: 1-40.
- Lesson, R.P. 1827. Description d'un nouveau genre de mollusques nucléobranches, nommé *Pterosoma*. *Mémoires de la Société d'Histoire Naturelle de Paris*, **3**: 414-417.
- Lesueur, [J.A.]. 1813. Mémoire sur quelques espèces d'animaux mollusques et radiaires recueillis dans la Méditerranée, près de Nice. *Nouveau Bulletin des Sciences, par la Société Philomatique*, **3** (69): 281-285.
- Lesueur, [J.A.]. 1817. Mémoire sur deux nouveaux genres de mollusques, Atlante et Atlas. *Journal de Physique, de Chimie, d'Histoire Naturelle et des Arts*, **85**: 390-393.
- Leyen, A. van & Spoel, S. van der. 1982. A new taxonomic and zoogeographic interpretation of the *Diacria quadridentata* group (Mollusca, Pteropoda). *Bulletin Zoologisch Museum, Universiteit van Amsterdam*, **8**: 101-117.
- Linden, J. van der. 2003. Atlantidae: wereldwijd voorkomen, maar weinig bekend. *Spirula, Correspondentieblad van de Nederlandse Malacologische Vereniging*, **335**: 129-132.
- Linné, C. von. 1758 (editio decima, reformata). *Systema naturae per regna tria naturae, secundum classes, ordines, genera, species, cum characteribus, differentiis, synonymis, locis*, 1. Salvii, Holmiae: 824 pp.
- Linné, C. von. 1767 (editio duodecima reformata). *Systema naturae*, 1 (2). L. Salvii, Holmiae: 533-1327.
- Mayer, C. 1868. Description de coquilles fossiles des terrains tertiaires supérieurs (suite). *Journal de Conchyliologie* (series 3), **8** (16): 102-112.
- McGowan, J.A. 1960. *The Systematics, Distribution, and Abundance of the Euthecosomata of the North Pacific*. Unpublished Ph.D. thesis, University of California, San Diego: 212 pp.
- Meisenheimer, J. 1905. Pteropoda. *Wissenschaftliche Ergebnisse der deutschen Tiefsee-Expedition auf dem Dampfer 'Valdivia' 1898-1899*, **9**: vi + 314 pp.
- Menzies, R.J. 1958. Shell-bearing pteropod gastropods from Mediterranean plankton (Cavoliniidae). *Pubblicazioni della Stazione zoologica di Napoli*, **30**: 381-401.
- Mörch, O.A.L. 1850. *Catalogus Conchyliorum quae reliquit C.P. Kierulf, Md. Dr., nunc Publica Auctione X Decembris MDCCCL Hafniae Dividenda*. Typis Trieri, Hafniae: 33 pp.
- Morlotti, E. & Torelli, L. 1980. Planktonic Foraminifera and Pteropoda distribution in surface sediments of the Sardinia Basin. *Volume dedicato a Sergio Venzo, Istituto Geologico, Parma*: 117-129.
- Niebuhr, C., 1775. *Descriptiones Animalium Avium, Amphibiorum, Piscium, Insectorum, Vermium; quae in Itinere orientali observavit Petrus Forskål, prof. Haun. Adjuncta est Materia Medica Kahirina atque Tabula Maris Rubri Geographica*. Möller, Haunia: 164 pp.
- Noda, H. 1972. Some fossil Pteropoda from Miyazaki and Okinawa prefectures, southwest Japan. *Trans-*

- actions and Proceedings of the Palaeontological Society of Japan* (new series), **88**: 472-484.
- Nordsieck, F. 1972. *Die europäischen Meeresschnecken (Opisthobranchia mit Pyramidellidae; Rissoacea)*. Fischer Verlag, Stuttgart: xiii + 327 pp.
- Ocampo, R.S. de 1983. *Plio-Pleistocene geology of Bolinao, Pangasinan & vicinities*. National Museum of the Philippines, Manila: 26 pp.
- Oken, [L. von], 1815. *Lehrbuch der Naturgeschichte*, 3. Zoologie, 1. *Fleischlose Thiere*. C.H. Reclam/Oken, Leipzig/Jena: xxviii + 842 + xviii pp.
- Okutani, T., 1955. On a new species of *Carinaria*, *C. japonica*. *Venus*, **18**: 251-258.
- Orbigny, A. d'. 1836-1846. *Voyage dans l'Amérique méridionale (le Brésil, la république orientale de l'Uruguay, la république Argentine, la Patagonie, la république du Chili, la république de Bolivie, la république du Pérou), exécuté pendant les années 1826, 1827, 1828, 1829, 1830, 1831, 1832 et 1833*, 5(3). *Mollusques*. Bertrand, Paris: 49-184 (1836); atlas (1846).
- Pacaud, J.-M. 2004. Révision des mollusques du Danien (Paléocène inférieur) du Bassin de Paris, 1. Gastropoda: Patellogastropoda et Vetigastropoda (pro parte). *Geodiversitas*, **26**: 577-629.
- Parker, W.K. & Jones, T.R., 1865. On some Foraminifera from the North Atlantic and Arctic Oceans, including Davis Straits and Baffin's Bay. *Philosophical Transactions of the Royal Society, London*, **155**: 325-441.
- Parker, W.K., Jones, T. R. & Brady, H.B. 1865 On the nomenclature of the Foraminifera, 12. *Annals and Magazine of Natural History* (series 3), **16**: 15-41.
- Pavia, G. & Robba, E. 1979. La località messiniana di Borelli (Collina di Torino) e la sua fauna a pteropodi. *Rivista Italiana di Paleontologia*, **85**: 549-572.
- Pchelintsev, V.F. & Korobkov, I.A. 1960. Osnovy paleologii. Spravochnik dlya paleontologov i geologov S.S.S.R. Molljuskij-Bryukhonogij (Podotryad Pteropoda). *Gosudarstvennoe Nauchno-Tekhnicheskoe. Izdatel'stvo. Literaturnie po Geologii i Okhrane Nedr, Moskva*: 251-252.
- Pelseneer, P. 1888. Report on the Pteropoda collected by H.M.S. *Challenger* during the years 1873-1876, 2. The Thecosomata. *Reports on the Scientific Results of the voyage of H.M.S. Challenger during the years 1873-1876*, **23**: 1-132.
- Péron, [F.] & Lesueur, [J.A.]. 1810. Histoire de la famille des mollusques ptéropodes; caractères de dix genres qui doivent la composer. *Annales du Muséum d'Histoire naturelle, Paris*, **15**: 57-68.
- Perrilliat, M. del Carmen. 1974. Monografía de los moluscos del Mioceno Medio de Santa Rosa, Veracruz, México, 3. Gastéropodos: Pyramidellidae a Siphonariidae. *Paleontologia Mexicana*, **37**: 1-46.
- Pfeffer, G. 1880. Die Pteropoden des Hamburger Museums. *Abhandlungen des Naturwissenschaftlichen Vereins in Hamburg*, **7**: 69-99.
- Phipps, C.J., 1774. *A Voyage towards the North Pole undertaken by his Majesty's Command 1773*. W. Bowyer & J. Nichols, London: 275 pp.
- Pilsbry, H.A. 1922. Revision of W.M. Gabb's Tertiary Mollusca of Santa Domingo. *Proceedings of the Academy of Natural Sciences of Philadelphia*, **73**: 305-435.
- Ponder, W.F. & D.R. Lindberg. 1995. Gastropod phylogeny, challenges for the 90's. In: Taylor, J.D. (ed.), *Origin and evolutionary radiation of the Mollusca*: 135-154. Oxford University Press, Oxford.
- Ponder, W.F. & Lindberg, D.R.. 1997. Towards a phylogeny of gastropod molluscs: an analysis using morphological characters. *Zoological Journal of the Linnean Society*, **119**: 83-265.
- Quoy, [J.R.C.] & Gaimard, [J.P.]. 1827. Observations zoologiques faites à bord de l'Astrolabe, en Mai 1826, dans le détroit de Gibraltar (suite et fin). Description des genres biphore, carinaire, hyale, flèche, cléodore, anatifé et briarée. *Annales des Sciences Naturelles*, **10**: 225-239, atlas.
- Rafinesque, C.S. 1814. *Précis des découvertes et travaux somiologiques de Mr. C.S. Rafinesque-Schmalz entre 1800 et 1814*. Palerme: 76 pp.
- Rampal, J. 1975. *Les thécosomes (mollusques pélagiques)*. *Systématique et évolution - écologie et biogéographie méditerranéennes*. Unpublished thesis, Université de Provence, Aix-Marseille: 485 pp.
- Rampal, J. 1985. Systématique du genre *Creseis* (Mollusques, Thécosomes). *Commission Internationale pour l'Exploration de la Mer Méditerranée, Monaco. Rapports et Procès-Verbaux des Réunions*, **29**: 259-263.
- Rampal, J. 1996. *Clio oblonga* n. sp. (Mollusque, Gastéropode, Euthécosome, Cavoliniidae, Clionae) fossile de thanatocoénoses quaternaires de la Méditerranée. *Géologie Méditerranéenne*, **23**: 175-185.
- Rampal, J. 2002. Biodiversité et biogéographie chez les Cavoliniidae (Mollusca, Gastropoda, Opistho-

- branchia, Euthecosomata). Régions faunistiques marines. *Zoosystema*, **24**: 209-258.
- Rang, [P.C.A.L.] 1827. Description de deux genres nouveaux (*Cuvieria* et *Euribia*) appartenant à la classe des ptéropodes. *Annales des Sciences Naturelles*, **12**: 320-329.
- Rang, [P.C.A.L.] 1828. Notice sur quelques mollusques nouveaux appartenant au genre cléodore, et établissement et monographie du sous-genre créseis. *Annales des Sciences Naturelles*, **13**: 302-319.
- Rang, S. [= P.C.A.L.] 1829. *Manuel de l'histoire naturelle des mollusques et de leurs coquilles, ayant pour base de classification celle de M. le Baron Cuvier*. Roret, Paris: vi + 390 pp.
- Reuss, A.E., 1867. Die fossile Fauna der Steinsalzablagerung von Wieliczka in Galizien. *Sitzungsberichte der mathematisch-naturwissenschaftlichen Classe der kaiserlichen Akademie der Wissenschaften, Wien*, **55**: 17-182.
- Richter, G. 1968. Heteropoden und Heteropodenlarven im Oberflächenplankton des Golfes von Neapel. *Pubblicazioni della Stazione zoologica di Napoli*, **36**: 347-400.
- Richter, G. 1972. Zur Kenntnis der Gattung *Atlanta* (Heteropoda: Atlantidae). *Archiv für Molluskenkunde*, **102**: 85-91.
- Richter, G. 1973. Zur Stammesgeschichte pelagischer Gastropoden. *Natur und Museum*, **103**: 265-275.
- Richter, G., 1974. Die Heteropoden der 'Meteor' Expedition in den Indischen Ozean 1964/65. 'Meteor' *Forschungsergebnisse* (serie D), **17**: 55-78.
- Richter, G. 1976a. Zur Frage der Verwandtschaftsbeziehungen von Limaciniidae und Cavoliniidae. *Archiv für Molluskenkunde*, **107**: 136-144.
- Richter, G. 1976b. *Creseis chierchiai* Boas, eigene Art oder Jugendstadium von *Hyalocyclus striata* (Rang)? *Archiv für Molluskenkunde*, **107**: 145-148.
- Richter, G. 1979. Die thecosomen Pteropoden der "Meteor"-Expedition in den Indischen Ozean 1964/65. 'Meteor' *Forschungsergebnisse* (series D), **29**: 1-29.
- Richter, G. 1986. Zur Kenntnis der Gattung *Atlanta*, 2. *Atlanta lesueurii* Souleyet und *Atlanta oligogyra* Tesch (Prosobranchia: Heteropoda). *Archiv für Molluskenkunde*, **117**: 19-31.
- Richter, G. 1987. Zur Kenntnis der Gattung *Atlanta*, 3. *Atlanta inflata*, *A. helicinooides*, *A. echinogyra* und *A. plana* (Prosobranchia: Heteropoda). *Archiv für Molluskenkunde*, **117**: 177-201.
- Richter, G. 1990. Zur Kenntnis der Gattung *Atlanta*, 4. Die *Atlanta inclinata*-Gruppe (Prosobranchia: Heteropoda). *Archiv für Molluskenkunde*, **119**: 259-275.
- Richter, G. 1993. Zur Kenntnis der Gattung *Atlanta*, 5. Die *Atlanta peroni*-Gruppe und *Atlanta gaudichaudi* (Prosobranchia: Heteropoda). *Archiv für Molluskenkunde*, **122**: 189-205.
- Richter, G. & Seapy, R.R. 1999. Heteropoda. In: D. Boltovskoy (ed.). *South Atlantic zooplankton*, 1. Backhuys, Leiden: 621-647.
- Richter, R. 1948. *Einführung in die zoologische Nomenklatur durch Erläuterung der Internationalen Regeln*. 2nd edition. Waldemar Kramer, Frankfurt: 252 pp.
- Risso, A. 1818. Memoire sur quelques gastéropodes nouveaux, nudibranches et tectibranches observés dans la mer de Nice, 1. *Journal de Physique, de Chimie, d'Histoire naturelle et des Arts, Paris*, **87**: 368-377.
- Röding, P.F. 1798. *Museum Boltenianum sive catalogus cimeliorum e tribus regnis naturae quae olim collegerat Joa. Fried Bolten*. Hamburg: 299 pp.
- Rottmann, M.L. 1980. Net tow and surface sediment distributions of pteropods in the South China Sea region: comparison and oceanographic implications. *Marine Micropaleontology*, **5**: 71-110.
- Rudman, W.B. 1999 (June 6). Larval shell. Sea Slug Forum. Australian Museum, Sydney. Available from: <http://www.seaslugforum.net/factsheet.cfm?base=larvshel>.
- Rudman, W.B. 2000 (May 25). Larval development and metamorphosis - *Aplysia oculifera*. Sea Slug Forum. Australian Museum, Sydney. Available from <http://www.seaslugforum.net/factsheet.cfm?base=aplyocdev>.
- Sakthivel, M. 1974. A new species of *Creseis* (Gastropoda, Mollusca) from the Laccadive Sea. *Current Science. Science in the Making*, **43**: 619-620.
- Scarsella, F. 1934. Di una nuova specie di pteropodo del Miocene appenninico. *Bollettino della Società Geologica Italiana*, **53**: 177-181.
- Schubert, R.J. 1910. Ueber Foraminiferen und einen Fischotolithen aus dem fossilen Globigerinen-

- schlamm von Neu-Guinea. *Abhandlungen des Geologischen Reichsanstalt, Wien*, **20**: 318-328.
- Seapy, R.R. 1990. The pelagic family Atlantidae (Gastropoda: Heteropoda) from Hawaiian waters: a faunistic survey. *Malacologia*, **32**: 107-130.
- Seapy, R.R., Lalli, C.M. & Wells F.E. 2003. Heteropoda from Western Australian waters. In: Wells, F.E., Walker D.E. & Jones D.S. (eds), *The marine flora and fauna of Dampier, Western Australia*: 513-546. Western Australian Museum, Perth.
- Seapy, R.R. & Richter, G. 1993. *Atlanta californiensis*, a new species of atlantid heteropod (Mollusca: Gastropoda) from the California Current. *Veliger*, **36**: 389-398.
- Seapy, R.R. & Skoglund, C. 2001. First records of atlantid heteropod mollusks from the Golfo de California. *The Festivus*, **33**: 33-44.
- Seapy, R.R. & Thiriou-Quiévreux, C. 1994. Veliger larvae of Carinariidae (Mollusca: Heteropoda) from Hawaiian waters. *Veliger*, **37**: 336-343.
- Seguenza, G. 1867. Paleontologia malacologia dei terreni terziarii del distretto di Messina (Pteropodi e Eteropodi). *Memorie della Società Italiana di Scienze Naturali*, **2**: 1-22.
- Seguenza, G. 1880. Le formazioni terziarie nella provincia di Reggio (Calabria). *Atti della reale Accademia dei Lincei*, (3), *Memorie della Classe di Scienze fisiche, matematiche e naturali*, **6**: 3-445.
- Shibata, H. 1979. Pelagic Mollusca from the Kakegawa Group and the Tamari Formation, Shizuoka Prefecture, Japan. *Bulletin of the Mizunami Fossil Museum*, **6**: 111-124. [In Japanese with English summary.]
- Shibata, H. 1980. Pteropods from the Early Miocene (Kurami and Saigo Groups) of the Kakegawa District and the Early to Middle Miocene (Yatsuo Formation) of the Yatsuo District, central Japan. *Bulletin of the Mizunami Fossil Museum*, **7**: 59-68. [In Japanese with English summary.]
- Shibata, H. 1983. Miocene pteropods from central Honshu, Japan. *Research Bulletin, College of General Education, Nagoya University*, **B27**: 65-86.
- Shibata, H. 1984. Pteropods and heteropods from the Upper Cenozoic of Kakegawa, Shizuoka Prefecture, Japan. *Bulletin of the Mizunami Fossil Museum*, **11**: 73-91.
- Shibata, H. 1986. Development of the Late Cenozoic pteropod fauna in central Japan. *Palaeontological Society of Japan, Special Papers*, **29**: 119-126.
- Shibata, H. & Ishigaki, T. 1981. Heteropodous and pteropodous biostratigraphy of Cenozoic strata of Chubu Province, Japan. *Bulletin of the Mizunami Fossil Museum*, **8**: 55-70. [In Japanese with English summary.]
- Shibata, H., Ishigaki, T. & Ujihara, A. 1986. Pteropods from the Late Neogene Nishiyatsushiro and Shizukawa Groups of Shimobe, Yamanashi Prefecture, Japan. *Bulletin of the Mizunami Fossil Museum*, **13**: 39-55.
- Shibata, H. & Ujihara, A. 1983. Middle and Late Pleistocene heteropods and pteropods from Chiba, Noto Peninsula and Kikaijima, Japan. *Bulletin of the Mizunami Fossil Museum*, **10**: 151-169.
- Simonelli, V. 1896. Appunti sopra la fauna e l'età dei terreni di Vigoleno. *Bollettino della Società Geologica Italiana*, **15**: 325-340.
- Smith, E.A. 1888. Report on the marine Mollusca collected by H.M.S. Challenger during the years 1873-1876. *Challenger Reports*, **72** (23): 1-51.
- Sorgenfrei, T. 1958. Molluscan assemblages from the marine Middle Miocene of south Jutland and their environments, 1-2. *Danmarks Geologiske Undersøgelse* (series 2), **79**: 1-355 (1); 366-503 (2).
- Souleyet, [F.L.A.] 1852a. In: Eydoux, [F.] & Souleyet, [F.L.A.], *Voyage autour du monde exécuté pendant les années 1836 et 1837 sur la corvette 'La Bonite', commandée par M. Vaillant, capitaine de vaisseau, publié par ordre du Gouvernement sous les auspices du département de la marine. Zoologie*, **2**. Mollusques; Pteropodes: 37-392, atlas (undated): pls 4-15, 15bis, 16-23, 23bis, 24, 24bis. A. Bertrand, Paris.
- Souleyet, [F.L.A.], 1852b. In: Rang, P.C.A.L. & Souleyet, [F.L.A.], *Histoire naturelle des mollusques ptéropodes. Monographie comprenant la description de toutes les espèces*: 86 pp. Baillièrre, Paris.
- Spengel, J.W. 1881. Die Geruchsorgane und das Nervensystem der Mollusken. *Zeitschrift für wissenschaftliche Zoologie*, **35** (for 1880): 333-383.
- Spoel, S. van der. 1962. Aberrant forms of the genus *Clio* Linnaeus, 1767, with a review of the genus *Proclio* Hubendick, 1951 (Gastropoda, Pteropoda). *Beaufortia*, **9**: 173-200.
- Spoel, S. van der. 1967. *Euthecosomata, a group with remarkable developmental stages* (Gastropoda, Pteropoda).

- J. Noorduijn, Gorinchem: 375 pp.
- Spoel, S. van der. 1968. A new form of *Diacria quadridentata* (Blainville, 1821) and shell growth in this species (Gastropoda, Pteropoda). *Videnskabelige Meddelelser fra Dansk Naturhistorisk Forening*, **131**: 217-224
- Spoel, S. van der. 1969. The shell of *Clio pyramidata* L. 1767 forma *lanceolata* (Lesueur, 1813) and forma *convexa* (Boas, 1886) (Gastropoda, Pteropoda). *Videnskabelige Meddelelser fra Dansk Naturhistorisk Forening*, **133**: 95-114.
- Spoel, S. van der. 1970. Morphometric data on Cavoliniidae with notes on a new form of *Cuvierina columnella* (Rang, 1827) (Gastropoda, Pteropoda). *Basteria*, **34**: 103-151.
- Spoel, S. van der. 1971. New forms of *Diacria quadridentata* (de Blainville, 1821), *Cavolinia longirostris* (de Blainville, 1821) and *Cavolinia uncinata* (Rang, 1829) from the Red Sea and the East Pacific Ocean (Mollusca, Pteropoda). *Beaufortia*, **19**: 1-20.
- Spoel, S. van der. 1972. Note on the identification and speciation of Heteropoda (Gastropoda). *Zoologische Mededelingen*, **47**: 545-560.
- Spoel, S. van der. 1973. *Clio pyramidata* Linnaeus, 1767 forma *convexa* (Boas, 1886) (Mollusca, Pteropoda). *Bulletin Zoologisch Museum Universiteit van Amsterdam*, **3**: 15-20.
- Spoel, S. van der. 1974. Geographical variation in *Cavolinia tridentata* (Mollusca, Pteropoda). *Bijdragen tot de Dierkunde*, **44**: 100-112.
- Spoel, S. van der. 1975. Preliminary note on variation of protoconchae of *Clio pyramidata* (Linnaeus, 1767) (Mollusca, Pteropoda). *Bulletin Zoologisch Museum Universiteit van Amsterdam*, **4** (21): 187-190.
- Spoel, S. van der. 1976a. Finer sculptures in euthecosomatous shells, and their value for taxonomy (Mollusca, Pteropoda). *Beaufortia*, **24**: 105-131.
- Spoel, S. van der. 1976b. *Pseudothecosomata, Gymnosomata and Heteropoda* (Gastropoda). Bohn, Scheltema & Holkema, Utrecht: 484 pp.
- Spoel, S. van der. 1987. *Diacavolinia* nov. gen. separated from *Cavolinia* (Pteropoda, Gastropoda). *Bulletin Zoologisch Museum Universiteit van Amsterdam*, **11**: 77-79.
- Spoel, S. van der, Bleeker, J. & Kobayasi, H. 1993. From *Cavolinia longirostris* to twenty-four *Diacavolinia* taxa, with a phylogenetic discussion (Mollusca, Gastropoda). *Bijdragen tot de Dierkunde*, **62**: 127-166.
- Spoel, S. van der & Dadon, J.R. 1999. Pteropoda. In: Boltovskoy, D. (ed.), *South Atlantic Zooplankton*: 649-706. Backhuys, Leiden.
- Spoel, S. van der & Diester-Haass, L. 1976. First records of fossil gymnosomatous protoconchae (Pteropoda, Gastropoda). *Bulletin Zoologisch Museum Universiteit van Amsterdam*, **5**: 85-88.
- Spoel, S. van der & Newman, L. 1990. Juveniles of the pteropod *Hyalocylis striata* (Gastropoda, Pteropoda). *Basteria*, **54**: 203-210.
- Spoel, S. van der & Troost, D.G. 1972. *Atlanta tokiokai*, a new heteropod (Gastropoda). *Basteria*, **36**: 1-6.
- Stainforth, R.M. 1948. Applied micropaleontology in coastal Ecuador. *Journal of Paleontology*, **22**: 113-151.
- Tate, R. 1887. The pteropods of the older Tertiary of Australia. *Transactions and Proceedings of the Royal Society of South Australia*, **9**: 194-196.
- Tesch, J.J. 1904. The Thecosomata and Gymnosomata of the Siboga Expedition. *Uitkomsten op Zoologisch, Botanisch, Oceanographisch en Geologisch Gebied verzameld in Nederlandsch Oost-Indië 1899-1900 aan boord H.M. Siboga onder commando van Luitenant ter Zee 1e kl. G.F. Tydeman*, **52**: 1-92.
- Tesch, J.J. 1906. Die Heteropoden der Siboga-Expedition. *Uitkomsten op Zoologisch, Botanisch, Oceanographisch en Geologisch Gebied verzameld in Nederlandsch Oost-Indië 1899-1900 aan boord H.M. Siboga onder commando van Luitenant ter Zee 1e kl. G.F. Tydeman*, **51**: 1-112.
- Tesch, J.J. 1908. The Pteropoda of the Leyden museum. *Notes from the Leyden Museum*, **29**: 181-203.
- Tesch, J.J. 1909. Systematic monograph of the Atlantidae (Heteropoda) with enumeration of the species in the Leyden museum. *Notes from the Leyden Museum*, **30**: 1-30.
- Tesch, J.J. 1913. Mollusca, Pteropoda. In: Schulze, F.E. (ed.), *Das Tierreich. Eine Zusammenstellung und Kennzeichnung der rezenten Tierformen*, **36**: xvi + 154 pp. Friedberger & Sohn, Berlin.
- Thiriot-Quévieux, C. 1973. Heteropoda. *Oceanography and Marine Biology. An Annual Review*, **11**: 237-261.
- Tiberi, N. 1878. Mollusques marins d'Italie. Céphalopodes, ptéropodes, hétéropodes vivant de la Médi-

- terraneé et fossiles du terrain tertiaire d'Italie. *Mémoires de la Société Malacologique de Belgique*, **13**: 52-84.
- Tiberi, N. 1880. Cefalopodi, pteropodi, eteropodi viventi nel Mediterraneo e fossili nel terreno terziario italiano con aggiunte e correzioni. *Bullettino della Società Malacologica Italiana*, **6**: 5-49.
- Tokioka, T. 1951. Droplets from the plankton net, 10. Record of *Creseis chierchiai* (Boas) from the Palao Islands. *Publications of the Seto Marine Biological Laboratory*, **1**: 184.
- Tokioka, T. 1955. On some plankton animals collected by the Syunkotu-Maru in May-June 1954, 2. Shells of Atlantidae (Heteropoda). *Publications of the Seto Marine Biological Laboratory*, **4**: 227-236.
- Torelli, L. & Buccheri, G. 1981. Late Quaternary stratigraphy of the Sardinia Basin sediments. In: Wezel, F.C. (ed.), *Sedimentary Basins of Mediterranean Margins*: 173-186. Tecnoprint, Bologna.
- Torelli, L. & Buccheri, G. 1983. Le associazioni a pteropodi del Pleistocene mediterraneo, 1. Analisi paleoclimatica della carota n. 1 del pozzo DSDP 125 (leg 13). *Geologica Romana*, **22**: 157-175.
- Ujihara, A. 1996. Pteropods (Mollusca, Gastropoda) from the Pliocene Miyazaki Group, Miyazaki Prefecture, Japan. *Journal of Paleontology*, **70**: 771-788.
- Ujihara, A., Shibata, H. & Saito, T. 1990. Pteropods from the Sagara Group (Mio-Pliocene), Shizuoka Prefecture, Japan. *Venus*, **49**: 306-329.
- Vaughan, T.W. & Woodring, W.P. 1921. Tertiary and Quaternary stratigraphic paleontology. In: Vaughan, T.W., Cooke, W., Condit, D.D., Ross, C.P., Woodring, W.P. & Calkins, F.C. (eds), *A geological reconnaissance of the Dominican Republic. Memoirs of the Geological Survey of the Dominican Republic*, **1**: 268 pp.
- Vayssière, A. 1915. Mollusques euptéropodes (ptéropodes thécosomes) provenant des campagnes des yachts Hironnelle et Princesse-Alice (1885-1913). *Résultats des Campagnes Scientifiques accomplies sur son yacht par Albert Ier, prince souverain de Monaco*, **47**: 226 pp.
- Vera, A. de & Seapy, R.R. 2006. *Atlanta selvagensis*, a new species of heteropod mollusc from the north-eastern Atlantic Ocean (Gastropoda: Carinarioidae). *Vieraea*, **34**: 45-54.
- Vinassa de Regny, P.E. 1898. Sopra un nuovo pteropode miocenico del Bolognese. *Rivista Italiana di Paleontologia*, **4**: 83-86. [Reprinted Amsterdam, Swetz & Zeitlinger, 1967.]
- Watson, R.B. 1898. On the marine Mollusca of Madeira; with descriptions of thirty five new species, and an index-list of all the known sea-dwelling species of that island. *Journal of the Linnean Society, London, Zoology*, **26**: 233-329.
- Wenz, W. 1941. *Handbuch der Paläozoologie. Gastropoda, 1. Allgemeiner Teil und Prosobranchia*, **5**: 961-1200. Bornträger, Berlin.
- Woodring, W.P. 1928. Miocene mollusks from Bowden Jamaica, 2. Gastropods and discussion of results. *Contributions to the Geology and Palaeontology of the West Indies*, **385**: vii + 564 pp.
- Woodring, W.P. 1970. Geology and paleontology of Canal Zone and adjoining parts of Panama. Description of Tertiary mollusks (gastropods: Eulimidae, Marginellidae to Helminthoglossidae). *Geological Survey Professional Papers*, **306D**: 299-452.
- Woodring, W.P., Brown, J.S. & Burbank, W.S. 1924. *Geology of the Republic of Haiti*. Geological Survey, Republic of Haiti, Port-au-Prince: 631 pp.
- Yamakawa, G. & Ishikawa, M. 1912. Some pteropods from the Neogene of Semata, 1-2. *Journal of the Geological Society of Tokyo*, **19**: 1-8.
- Yokoyama, M. 1890. Versteinerungen aus der japanischen Kreide. *Palaeontographica*, **36**: 159-202.

Note added in proof (see p. 91) – Recently collected pteropod material from Santa Maria Island, the Azores, includes many topotypical specimens of *Cavolinia marginata* (Bronn), which surprisingly was found to be a senior synonym of *C. vendryesiana* (Guppy) (Janssen and co-workers, research in progress).

Plate 1

Protatlanta rotundata (Gabb, 1873)

Fig. 1. Anda6, RGM 517 522. a, apical. b, umbilical. c, apertural view.

Oxygyrus keraudreni (Lesueur, 1817).

Fig. 2. Holotype of *Sphaeratys globulinus* Nordsieck, 1972. Recent, Ibiza, 20 m (SMF, F. Nordsieck collection). Apertural view.

Fig. 3. Anda4, RGM 517 510. a, apical. b, apertural view.

Carinaria cf. *lamarcki* auct., Péron & Lesueur, 1810?

Fig. 4. Anda2, RGM 517 541. Lateral view.

Janthina (*Janthina*) *prolongata* de Blainville, 1822

Fig. 5. Anda1, RGM 517 582. a, apertural. b, lateral view.

Fig. 6. Anda2, RGM 517 583. Juvenile specimen with last protoconch whorl retained. a, lateral. b, apertural view.

Heliconoides sondaari sp. nov.

Fig. 7. Holotype. Anda3, RGM 517 586. a, apical. b, lateral. c, apertural view.

Limacina bulimoides (d'Orbigny, 1836)

Fig. 8. Anda1, RGM 517 598. Apertural view.

Fig. 9. Anda1, RGM 517 599. Lateral view.

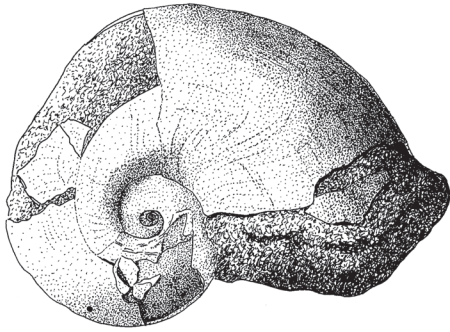

1a (x 6)

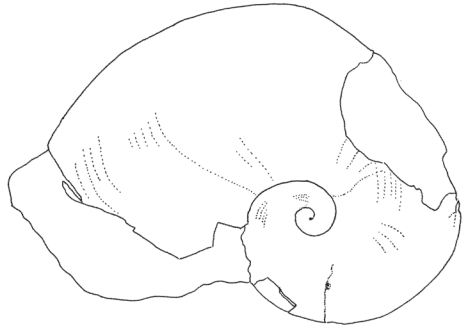

1b (x 6)



2 (x 25)

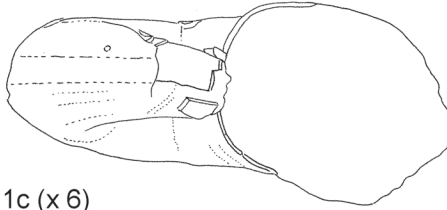

1c (x 6)



4 (x 3)

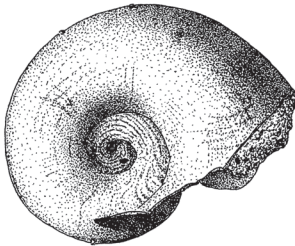

3a (x 12 1/2)

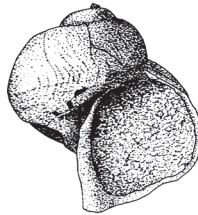

5a (x 3)

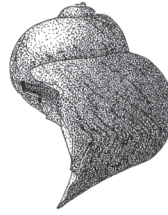

5b (x 3)



6a (x 25)

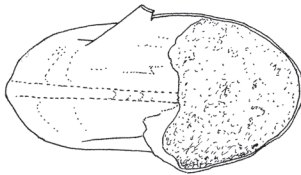

3b (xz 12 1/2)



7a (x 25)

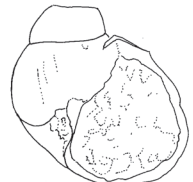

6b (x 25)

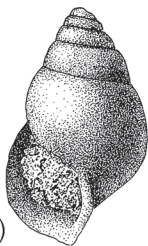

8 (x 25)

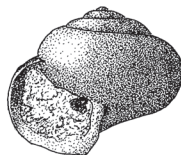

7c (x 25)

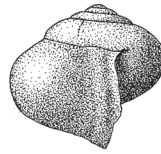

7b (x 25)



9 (x 25)

Plate 2

Heliconoides inflata (d'Orbigny, 1836)

Fig. 1. Anda3, RGM 517 572. Apical view.

Fig. 2. Anda2, RGM 517 569. Lateral view.

Fig. 3. Anda2, RGM 517 570. Juvenile. a, apical. b, apertural. c, oblique apical. d, umbilical view.

Striolimacina andaensis sp. nov.

Fig. 4. Holotype. Anda4, RGM 517 615. a, apical. b, apertural. c, oblique apical view.

Fig. 5. Paratype. Anda4, RGM 517 616. a, apical. b, apertural. c, oblique apical. d, umbilical view.

Limacinidae? sp.

Fig. 6. Anda1, RGM 517 623. a, apical. b, apertural. c, umbilical view.

Creseis chierchiaie (Boas, 1886) forma *constricta* Chen & Bé, 1964

Fig. 7. Anda4, RGM 517 633. a, apertural. b, frontal. c, lateral view.

Fig. 8. Anda4, RGM 517 634. a, apertural. b, frontal. c, lateral view.

Creseis clava (Rang, 1828)

Fig. 9. Anda2, RGM 517 643. a, frontal view. b, protoconch.

Fig. 10. Anda2, RGM 517 644. a, frontal view. b, protoconch.



1 (x 25)

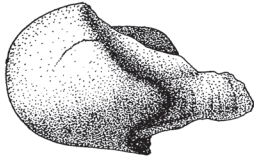

2 (x 25)

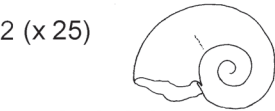

6a (x 25)



6b (x 25)



6c (x 25)

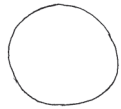

7a (x 25)

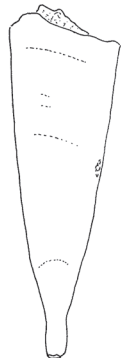

7b (x 25)

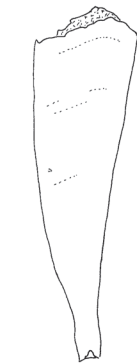

7c (x 25)



3a (x 25)



3b (x 25)



3c (x 25)



3d (x 25)

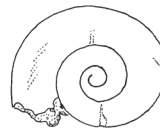

4a (x 25)



4b (x 25)



4c (x 25)

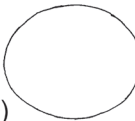

8a (x 25)

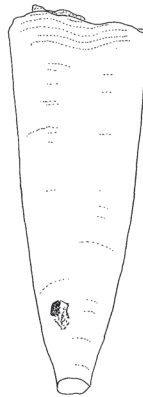

8b (x 25)



9b (x 25)

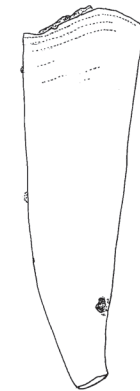

8c (x 25)



10a (x 12 1/2)



10b (x 25)



5a (x 25)



5b (x 25)

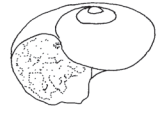

5c (x 25)



5d (x 25)

9a (x 12 1/2)

Plate 3

Styliola subula (Quoy & Gaimard, 1827)

Fig. 1. AndaClif3, RGM 429 321. Specimen with double furrow.

Fig. 2. Anda1, RGM 517 674. Specimen with several furrows near apertural margin, after shell repair.

Fig. 3. Anda1, RGM 517 675. Specimen with three furrows.

Fig. 4. Anda4, RGM 517 683a, b. Specimen with displacement of furrow over 180° after shell repair.

Hyalocylis marginata sp. nov.

Fig. 5. Paratype. Anda6, RGM 517 655. Ventral view.

Fig. 6. Holotype. Anda6, RGM 517 654. Left lateral view.

Cuvierina (Urceolarica) urceolaris (Mörch, 1850)

Fig. 7. Anda1, RGM 517 699. a, apertural. b, ventral. c, left lateral view.

Fig. 8. Anda6, RGM 517 712. a, apertural. b, ventral. c, left lateral view.

Fig. 9. Anda4, RGM 517 708. Specimen retaining larval shell, ventral view.

Clio (Bellardiclio) cuspidata (Bosc, 1802)

Fig. 10. Anda2, RGM 517 722. Ventral view.

Fig. 11. Anda2, RGM 517 721. Dorsal view.

Clio (Balantium) cf. hataii (Noda, 1972)

Fig. 12. Anda3, RGM 517 718. Ventral view.

Clio (Clio) convexa convexa (Boas, 1886)

Fig. 13. Anda1, RGM 517 736. a, dorsal. b, right lateral. c, ventral view. d, protoconch, ventral view. e, protoconch lateral view.

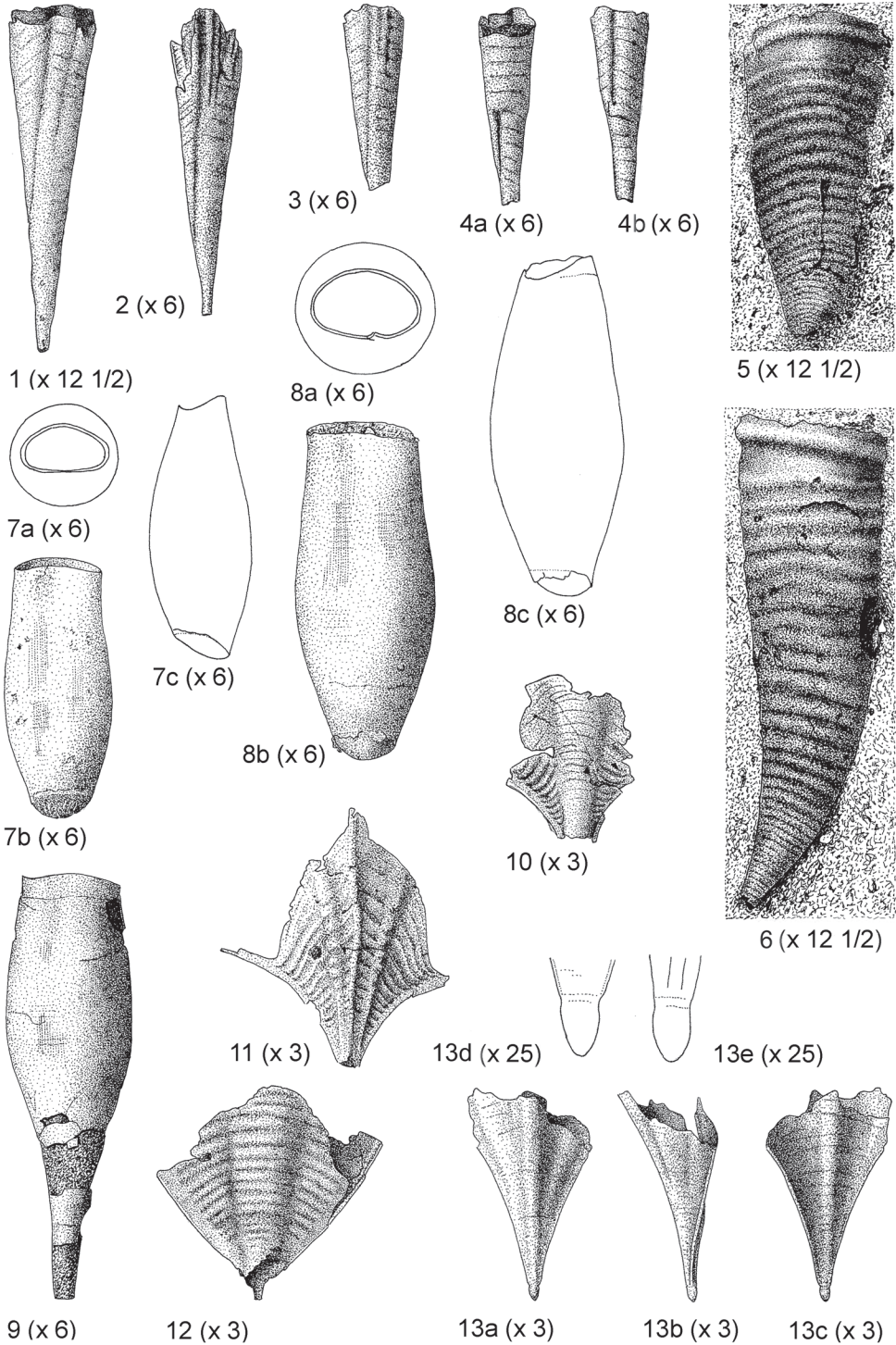

Plate 4

Clio (Clio) convexa convexa (Boas, 1886)

Fig. 1. Off southeast Salayer, Sulawesi, Indonesia, 6° 22' S 120° 26' E. Snellius expedition Station 4.155, Recent. RGM 517 381. Right lateral view.

Fig. 3. Anda1, RGM 517 736. Right lateral view.

Clio (Clio) convexa cyphosa Rampal, 2002

Fig. 2. Southern Red Sea, Recent, leg./don. K. Bandel. RGM 517 382. Right lateral view.

Clio (Clio) pyramidata Linné, 1767 forma *lanceolata* (Lesueur, 1813)

Fig. 4. Anda4, RGM 517 758. a, apertural. b, dorsal. c, right lateral. d, ventral view.

Cavolinia baniensis sp. nov.

Fig. 5. Holotype. Tiep2, RGM 517 773. a, dorsal. b, left lateral. c, ventral view.

Cavolinia globulosa (Gray, 1850)

Fig. 6. Off southeast Salayer, Sulawesi, Indonesia, 6° 22' S 120° 26' E. Snellius expedition Station 4.155, Recent. RGM 517 421. a, dorsal. b, left lateral. c, ventral view.

Cavolinia landaui Janssen, 2004

Fig. 7. Anda1, RGM 517 777. a, dorsal. b, right lateral. c, ventral view.

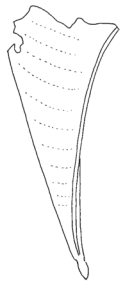

1 (x 6)

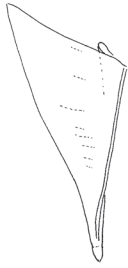

2 (x 6)

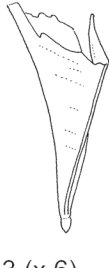

3 (x 6)

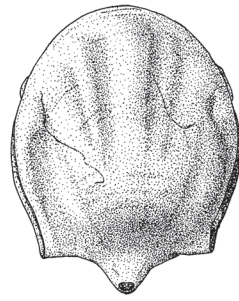

5a (x 6)

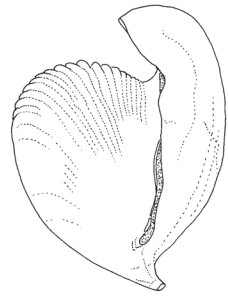

5b (x 6)



4a (x 6)



4c (x 6)

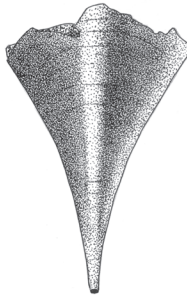

4d (x 6)

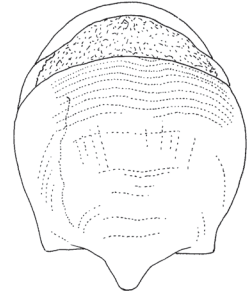

5c (x 6)

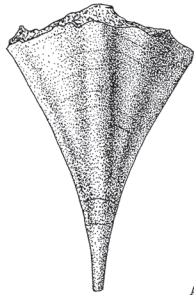

4b (x 6)

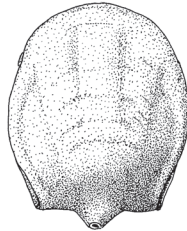

6a (x 6)



6b (x 6)

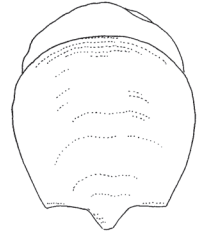

6c (x 6)

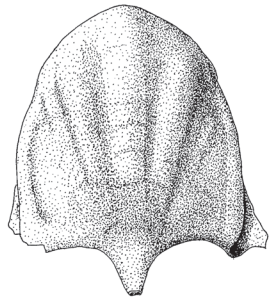

7a (x 6)

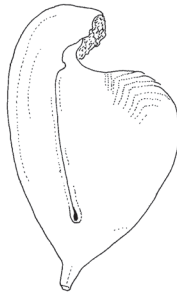

7b (x 6)

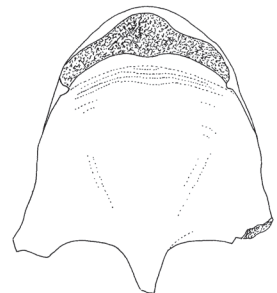

7c (x 6)

Plate 5

Cavolinia landaui Janssen, 2004

Fig. 1. Anda4, RGM 517 783. Dorsal view.

Cavolinia perparvula sp. nov.

Fig. 2. Holotype. Anda4, RGM 517 794. a, dorsal. b, left lateral. c, ventral view.

Fig. 3. Paratype. Anda4, RGM 517 795. a, dorsal. b, left lateral. c, ventral view.

Cavolinia shibatai sp. nov.

Fig. 4. Paratype. Tiep2, RGM 517 814. Specimen retaining long lateral spine, dorsal view.

Fig. 5. Holotype. Tiep2, RGM 517 813. a, dorsal. b, right lateral. c, ventral view.

Fig. 6. Paratype. Anda2, RGM 517 819. Specimen retaining both lateral spines, dorsal view.

Cavolinia tridentata (Niebuhr, 1775)

Fig. 7. Anda1, RGM 517 820. a, dorsal. b, left lateral. c, ventral view.

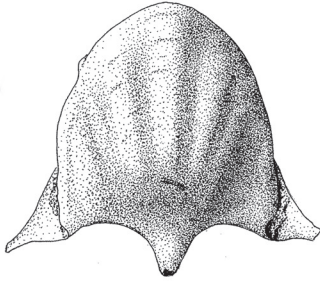

1 (x 6)

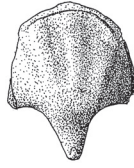

2a (x 12 1/2)



2b (x 12 1/2)



2c (x 12 1/2)

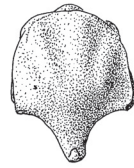

3a (x 12 1/2)



3b (x 12 1/2)

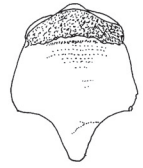

3c (x 12 1/2)

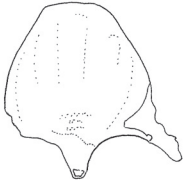

4 (x 6)

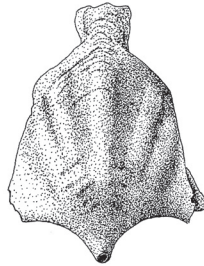

5a (x 6)

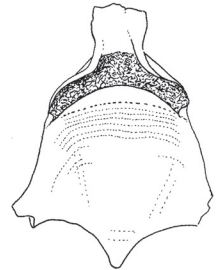

5b (x 6)

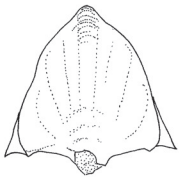

6 (x 6)



5c (x 6)

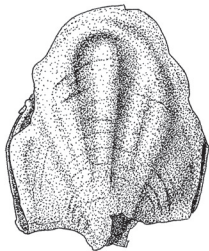

7a (x 3)



7b (x 3)

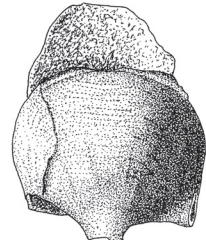

7c (x 3)

Plate 6

Cavolinia vendryesiana (Guppy, 1873) forma *hyugaensis* Ujihara, 1996

Fig. 1. Anda2, RGM 517 838. a, dorsal. b, right lateral. c, ventral view.

Cavolinia ventricosa (Guppy, 1882)

Fig. 2. AndaDeVos, RGM 517 848. a, dorsal. b, right lateral view.

Cavolinia sp. 1

Fig. 3. Anda6, RGM 517 849. Dorsal view.

Cavolinia sp. 2

Fig. 4. Tiep1, RGM 517 851. a, dorsal. b, right lateral. c, ventral view.

Diacavolinia pristina sp. nov.

Fig. 5. Holotype. Anda4, RGM 517 873. a, dorsal. b, left lateral. c, ventral view.

Fig. 6. Paratype. Anda1, RGM 517 870. a, dorsal. b, right lateral. c, ventral view.

Diacria italica Grecchi, 1982

Fig. 7. Holotype. Volpedo, Ca' Barbieri (Italy, Alessandria), Pliocene, Piacenzian. Coll. Università degli Studi di Milano, Sezione Geologia e Paleontologia, Milano, Italy (illustrated in Grecchi, 1982, pl. 54, fig. 1). a, apertural. b, dorsal. c, ventral. d, left lateral view.

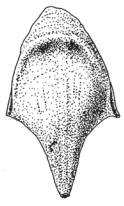

1a (x 6)

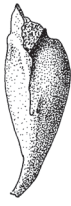

1b (x 6)

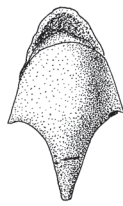

1c (x 6)



3 (x 6)

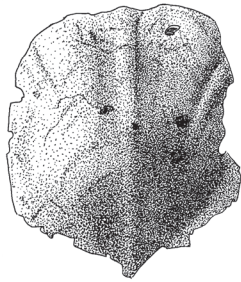

2a (x 12 1/2)



2b (x 12 1/2)



4a (x 6)



4c (x 6)



4b (x 6)

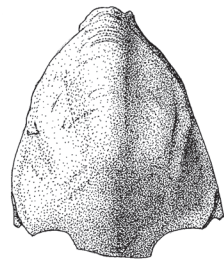

5a (x 12 1/2)

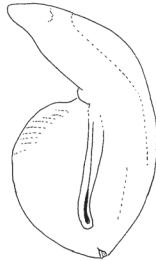

5b (x 12 1/2)

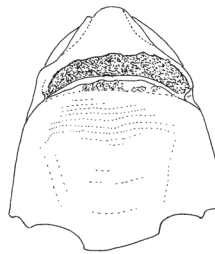

5c (x 12 1/2)

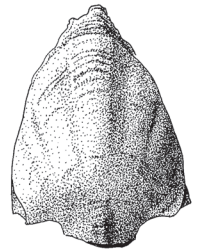

6a (x 12 1/2)

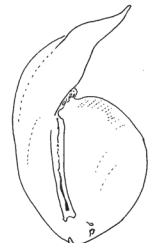

6b (x 12 1/2)



7a (x 6)



7c (x 6)

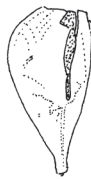

7d (x 6)

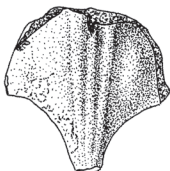

7b (x 6)

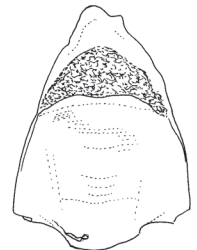

6c (x 12 1/2)

Plate 7

Diacria italica Grecchi, 1982 forma *fissicostata* n. f.

Fig. 1. Holotype. Anda1, RGM 517 875. Dorsal view.

Fig. 2. Paratype. Anda4, RGM 517 886. a, dorsal. b, left lateral. c, ventral view.

Diacria philippinensis sp. nov.

Fig. 3. Holotype. Anda1, RGM 517 904. a, dorsal. b, left lateral. c, ventral view.

Diacria trispinosa (de Blainville, 1822) f. *bisulcata* Gabb, 1873

Fig. 4. Anda1, RGM 517 933. a, dorsal. b, left lateral. c, ventral view.

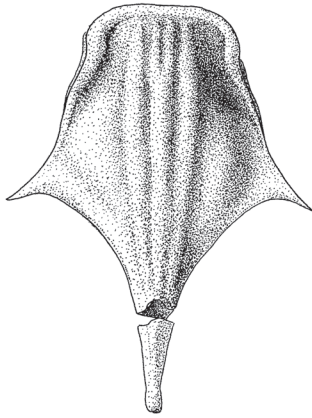

1 (x 12 1/2)

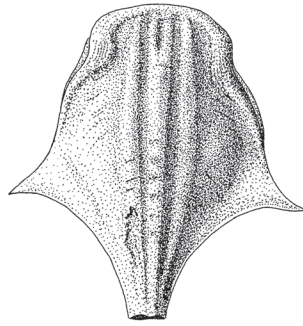

2a (x 12 1/2)

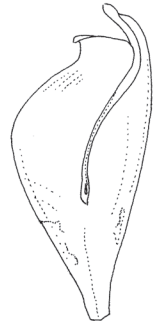

2b (x 12 1/2)

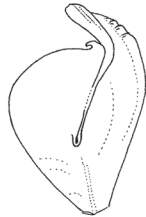

3b (x 12 1/2)

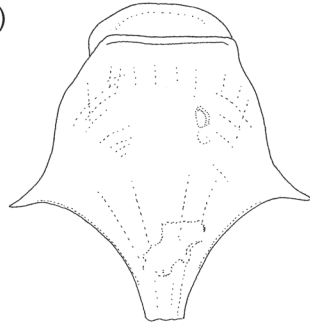

2c (x 12 1/2)

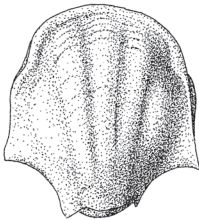

3a (x 12 1/2)

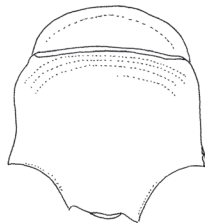

3c (x 12 1/2)

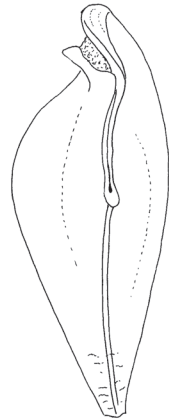

4b (x 12 1/2)

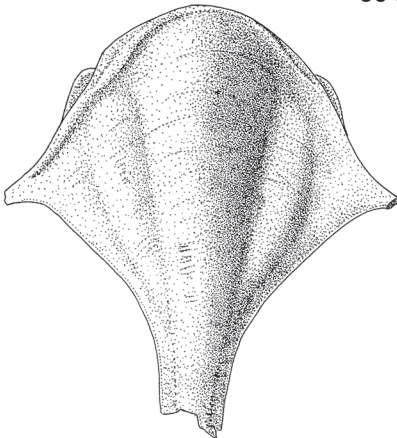

4a (x 12 1/2)

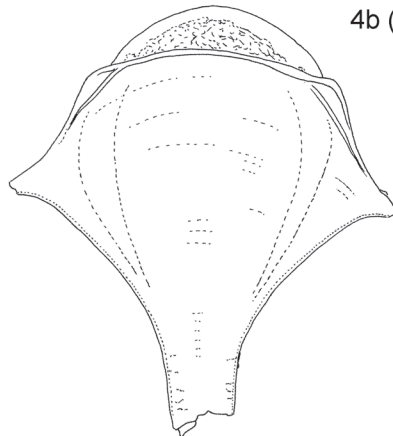

4c (x 12 1/2)

Plate 8

Diacria microstriata sp. nov.

Fig. 1. Holotype. AndaDeVos, RGM 517 891. a, dorsal. b, right lateral. c, ventral view.

Diacria paeninsula sp. nov.

Fig. 2. Holotype. Anda2, RGM 517 896. a, dorsal. b, left lateral. c, ventral view.

Fig. 3. Paratype (protoconch). Tjep4, RGM 517 961. a, frontal. b, lateral view.

Fig. 4. Paratype (protoconch). Anda3, RGM 517 899. a, frontal. b, lateral view.

Diacria trispinosa (de Blainville, 1822) f. *bisulcata* Gabb, 1873

Fig. 5. Anda1, RGM 517 935. Protoconch. a, frontal. b, lateral view.

Diacria philippinensis sp. nov.

Fig. 6. Paratype. Anda1, RGM 517 930. Protoconch. a, frontal. b, lateral view.

Diacria italica Grecchi, 1982 f. *fissicostata* f. nov.

Fig. 7. Paratype. Anda1, RGM 517 879. Protoconch. a, frontal. b, lateral view.

Sphaerocina convolvula sp. nov.

Fig. 8. Holotype. AndaDeVos, RGM 517 963. a, right lateral. b, apertural view.

Peraclis reticulata (d'Orbigny, 1836)

Fig. 9. Anda1, RGM 517 966. a, apical. b, apertural view.

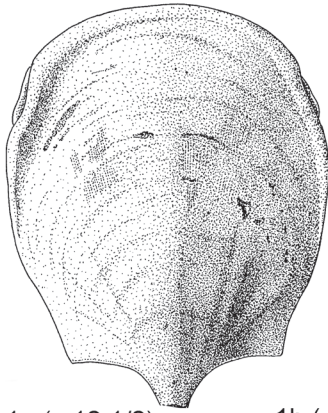

1a (x 12 1/2)

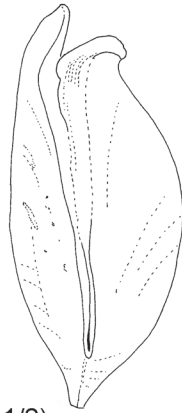

1b (x 12 1/2)

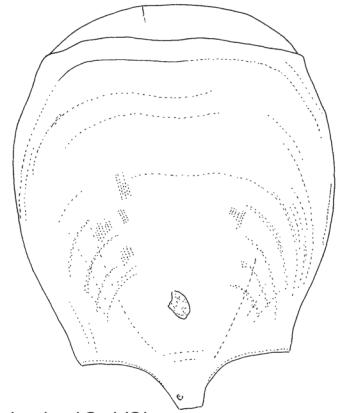

1c (x 12 1/2)

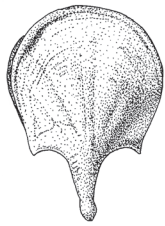

2a (x 12 1/2)

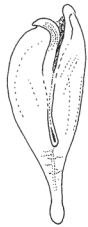

2b (x 12 1/2)

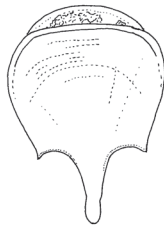

2c (x 12 1/2)

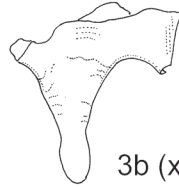

3a (x 25)

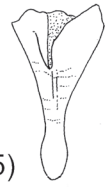

3b (x 25)

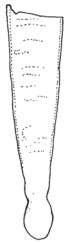

5a (x 25)



5b (x 25)

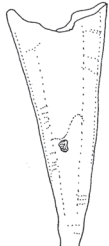

6a (x 25)



6b (x 25)

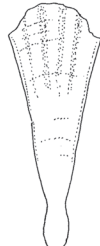

7a (x 25)



7b (x 25)



4a (x 25)



4b (x 25)

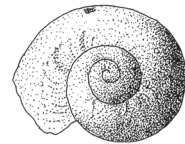

9a (x 25)

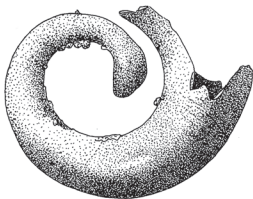

8a (x 25)

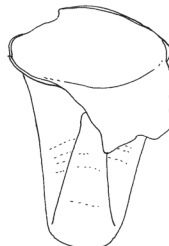

8b (x 25)

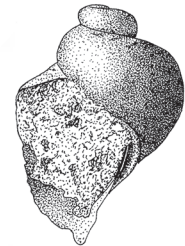

9b (x 25)

Plate 9

Atlanta cf. echinogyra Richter, 1972

Fig. 1. AndaDeVos, RGM 539 760. a, apical view. b, apical view, detail. c, protoconch, oblique apical view.

Atlanta fusca Souleyet, 1852b

Fig. 2. Anda2, RGM 539 761. a, apical view. b, protoconch, apical view. c, nucleus and first whorl, apical view. d, protoconch, oblique apical view.

Fig. 3. Anda2, RGM 539 763. Protoconch, apertural view.

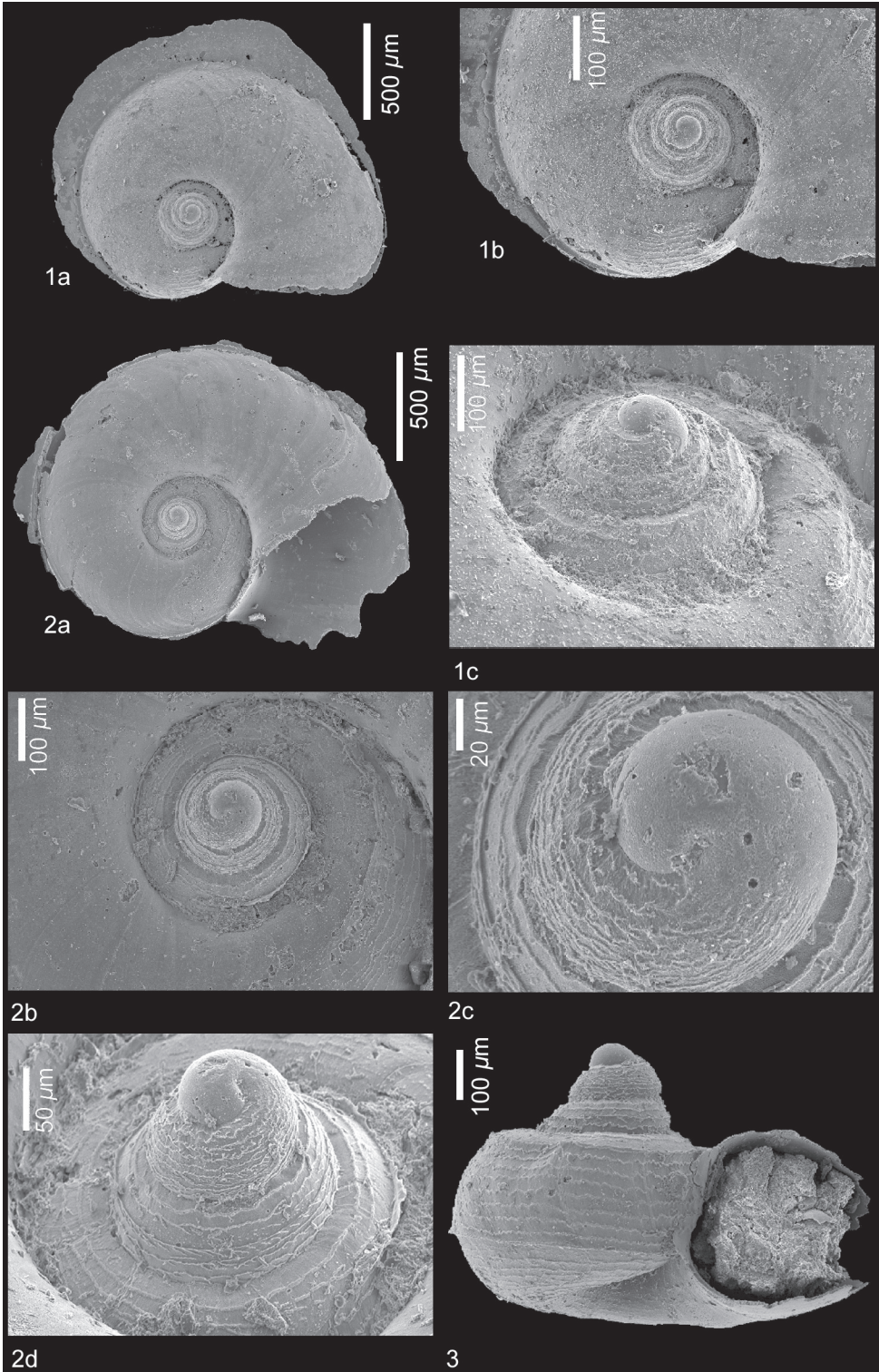

Plate 10

Atlanta fusca Souleyet, 1852b

Fig. 1. Anda2, RGM 539 762. a, protoconch, lateral view. b, nucleus and first whorl, lateral view.

Atlanta lesueuri Souleyet, 1852b

Fig. 2. Roxas, RGM 539 764. a, apical view. b, protoconch, apical view.

Fig. 3. Anda2, RGM 539 845. a, apical view. b, oblique apical view.

Atlanta lingayanensis sp. nov.

Fig. 4. Holotype. AndaClif3, RGM 539 846. a, apical view. b, protoconch, apical view.

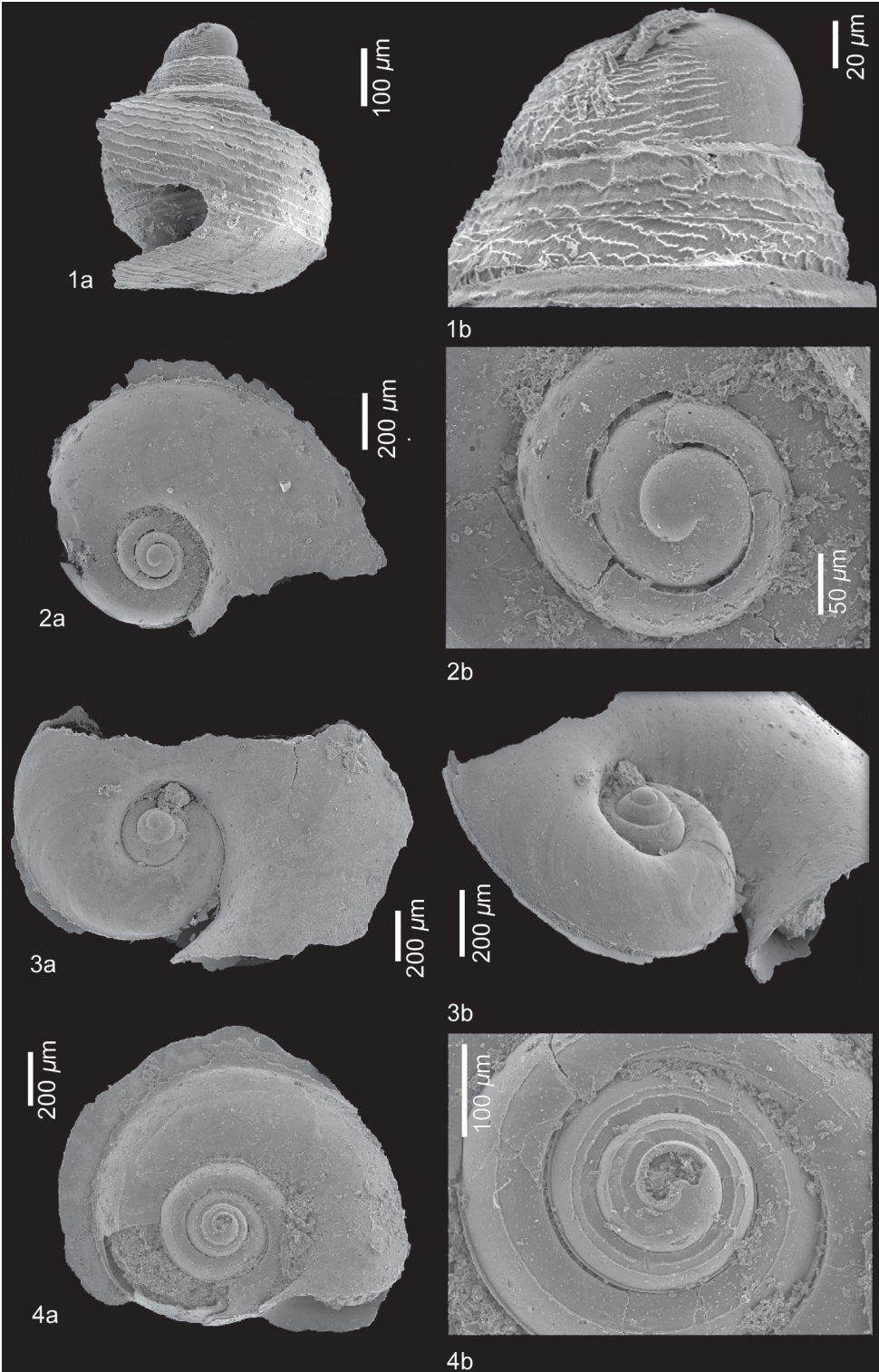

Plate 11

Atlanta lingayanensis sp. nov.

Fig. 1. Paratype. AndaClif3, RGM 539 765. Protoconch, apertural view.

Atlanta oligogyra Tesch, 1906

Fig. 2. Anda1, RGM 539 847. a, apical view. b, protoconch, apical view. c, protoconch, oblique apical view.

Fig. 3. Tiep5, RGM 539 848. a, apical view. b, protoconch, oblique apical view.

Atlanta peroni Lesueur, 1817

Fig. 4. Anda2, RGM 539 766. a, apical view. b, protoconch, oblique apical view.

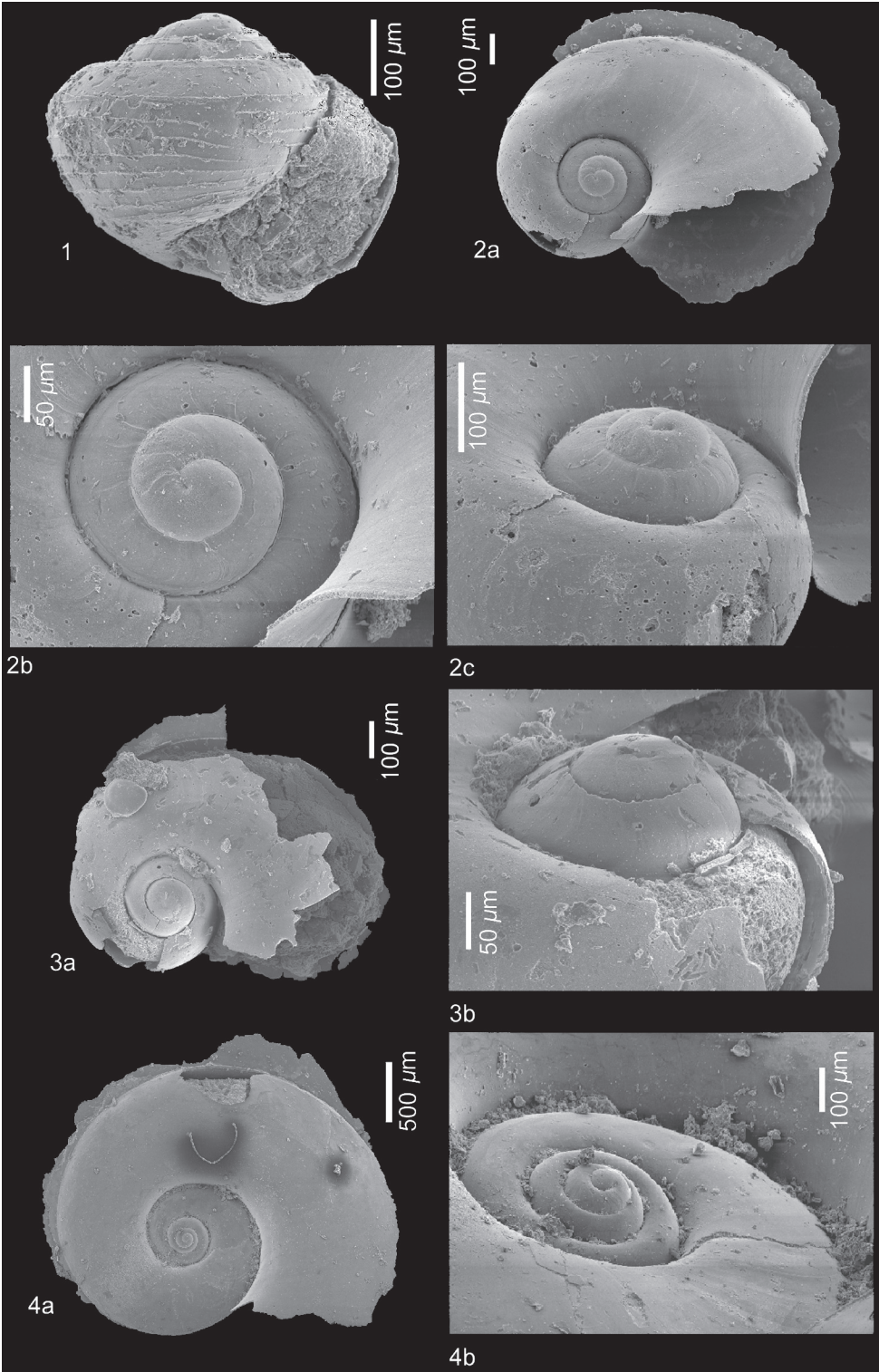

Plate 12*Atlanta peroni* Lesueur, 1817

Fig. 1. Anda2, RGM 539 766. Protoconch, apical view.

Fig. 2. Anda2, RGM 539 767. Protoconch, apertural view.

Fig. 3. Anda2, RGM 539 768. Protoconch, apical view.

Atlanta plana Richter, 1972

Fig. 4. Anda2, RGM 539 769. a, apical view. b, apical view, detail. c, protoconch, apical view. d, oblique apical view.

Fig. 5. Tiep5, RGM 539 770. Protoconch. apertural view.

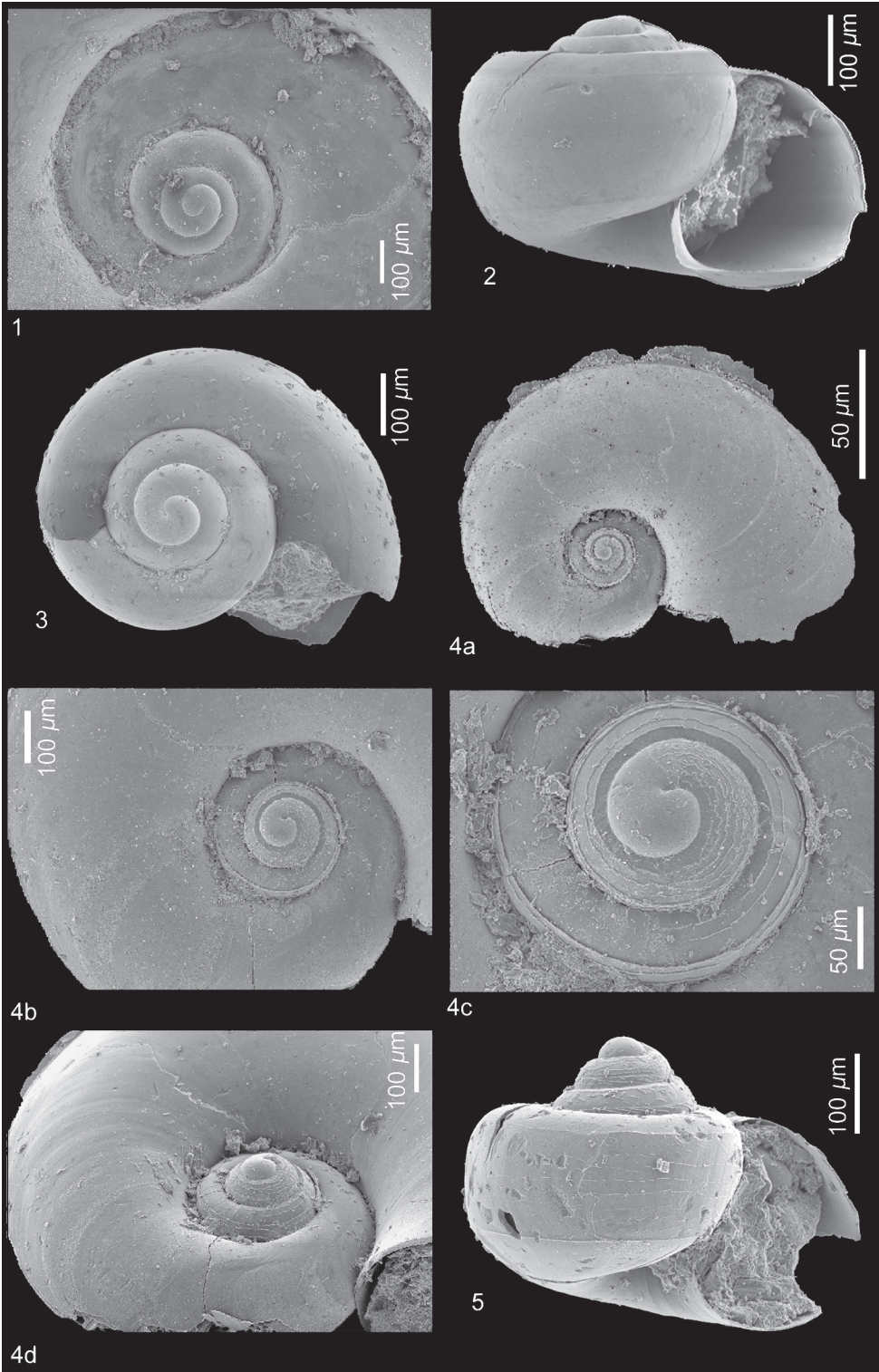

Plate 13*Atlanta plana* Richter, 1972

Fig. 1. Tiep5, RGM 539 771. a, apical view. b, protoconch, apical view.

Atlanta richteri sp. nov.

Fig. 2. Paratype. Anda3, RGM 539 772. a, protoconch, apical view. b, protoconch, apical view, detail.

Fig. 3. Paratype. Anda3, RGM 539 773. Protoconch, apertural view.

Fig. 4. Paratype. Anda4, RGM 539 774. a, apical view. b, protoconch, apical view. c, protoconch, oblique apical view.

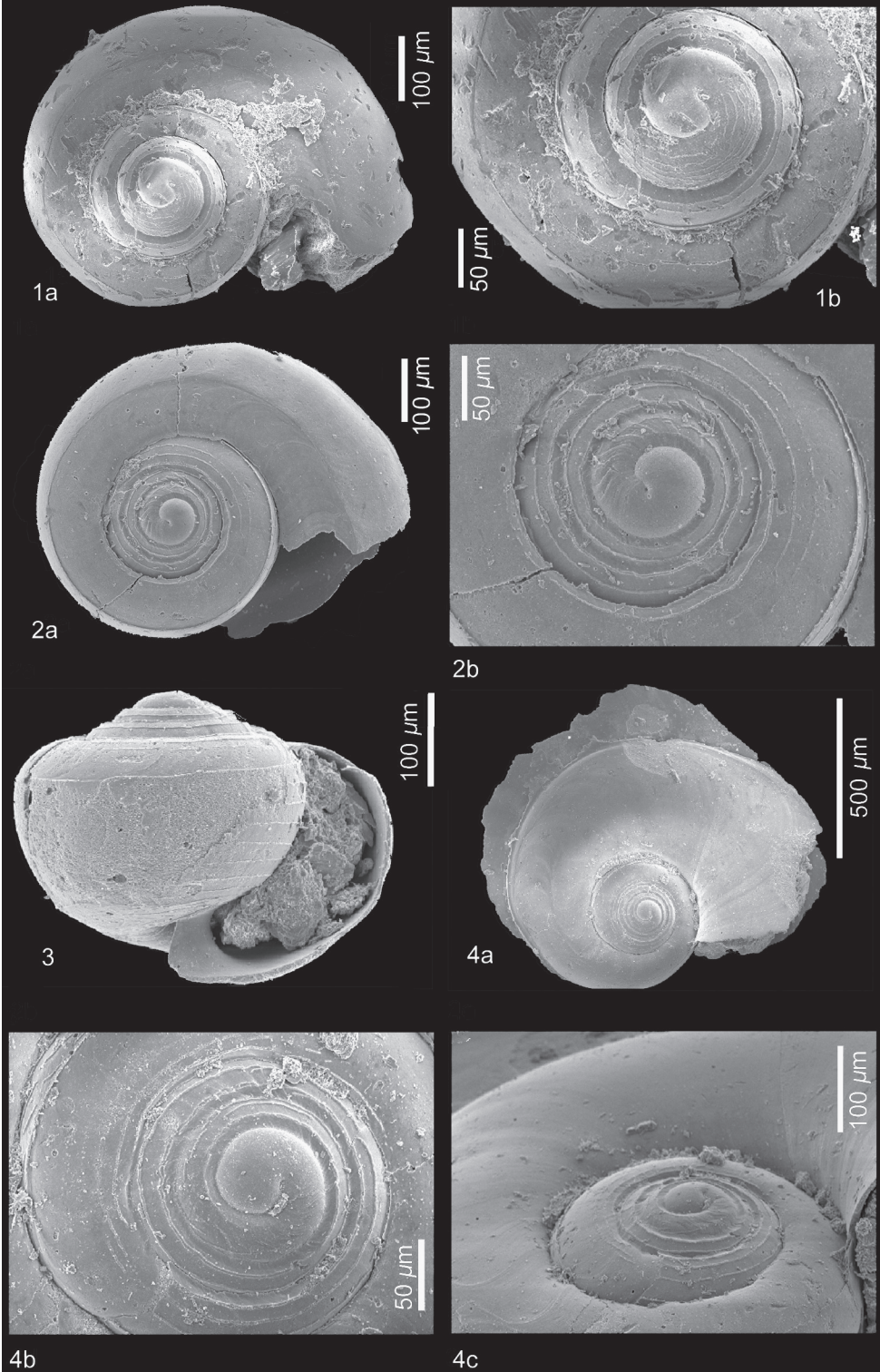

Plate 14

Atlanta richteri sp. nov.

Fig. 1. Paratype. Anda4, RGM 539 775. Umbilical view.

Fig. 2. Holotype. Anda2, RGM 517 474. a, apical view. b, protoconch, apical view. c, nucleus of protoconch, apical view.

Atlanta seapyi sp. nov.

Fig. 3. Holotype. Anda1, RGM 517 482. a, apical view. b, protoconch, apical view. c, protoconch, oblique apical view. d, detail of protoconch suture.

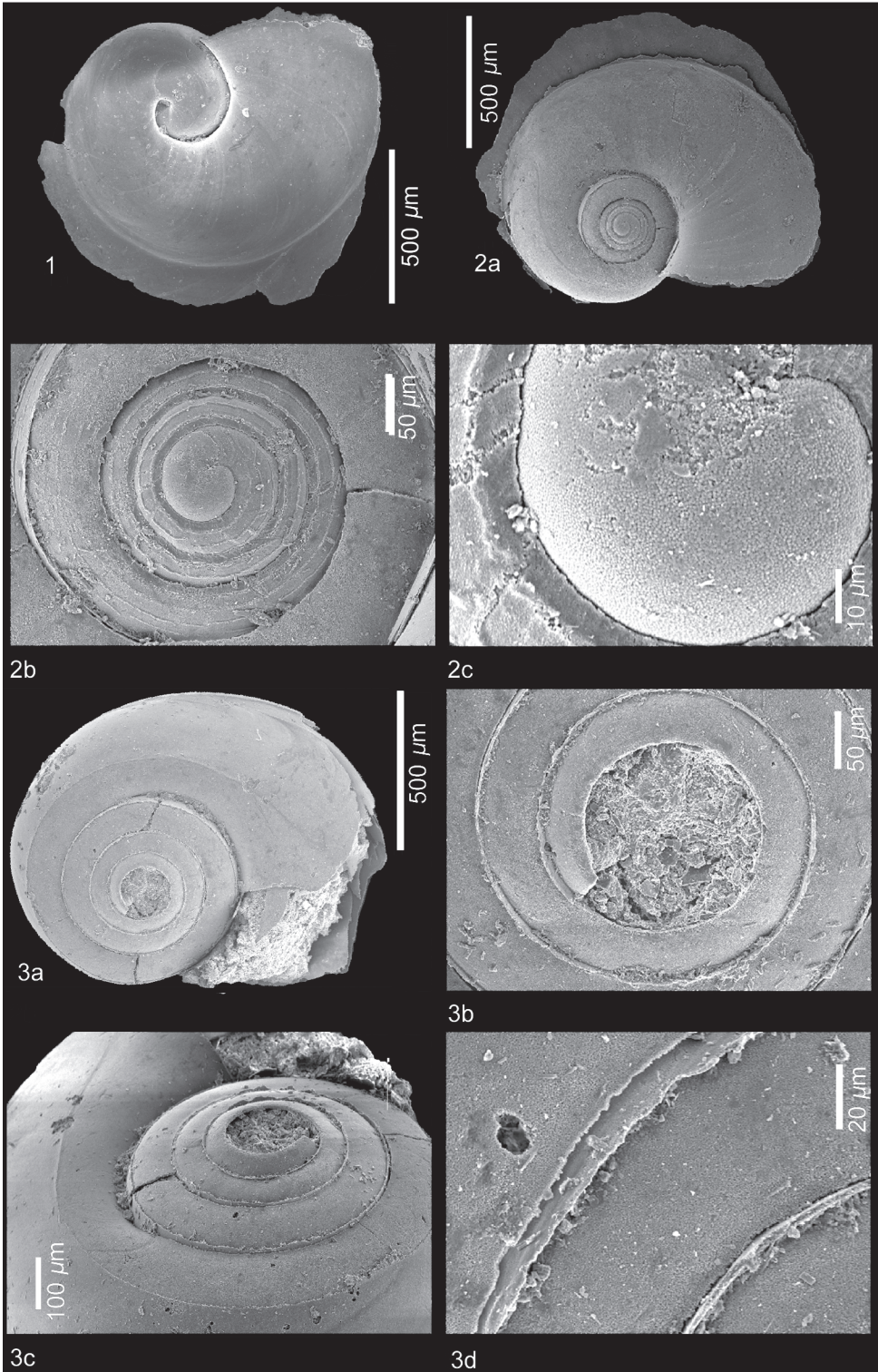

Plate 15

Atlanta seapyi sp. nov.

Fig. 1. Paratype. Tiep3, RGM 539 778. Protoconch, apertural view (first whorl out of place).

Fig. 2. Paratype. AndaClif3, RGM 539 779. a, protoconch, apertural view. b, detail of Figure 2a.

Fig. 3. Paratype. Tiep5, RGM 539 780. Protoconch, oblique lateral view.

Atlanta tokiokai van der Spoel & Troost, 1972

Fig. 4. Anda3, RGM 539 781. a, apical view. b, protoconch, oblique apical view. c, micro-ornament on last protoconch whorl.

Fig. 5. Anda3, RGM 539 849. Protoconch, apertural view.

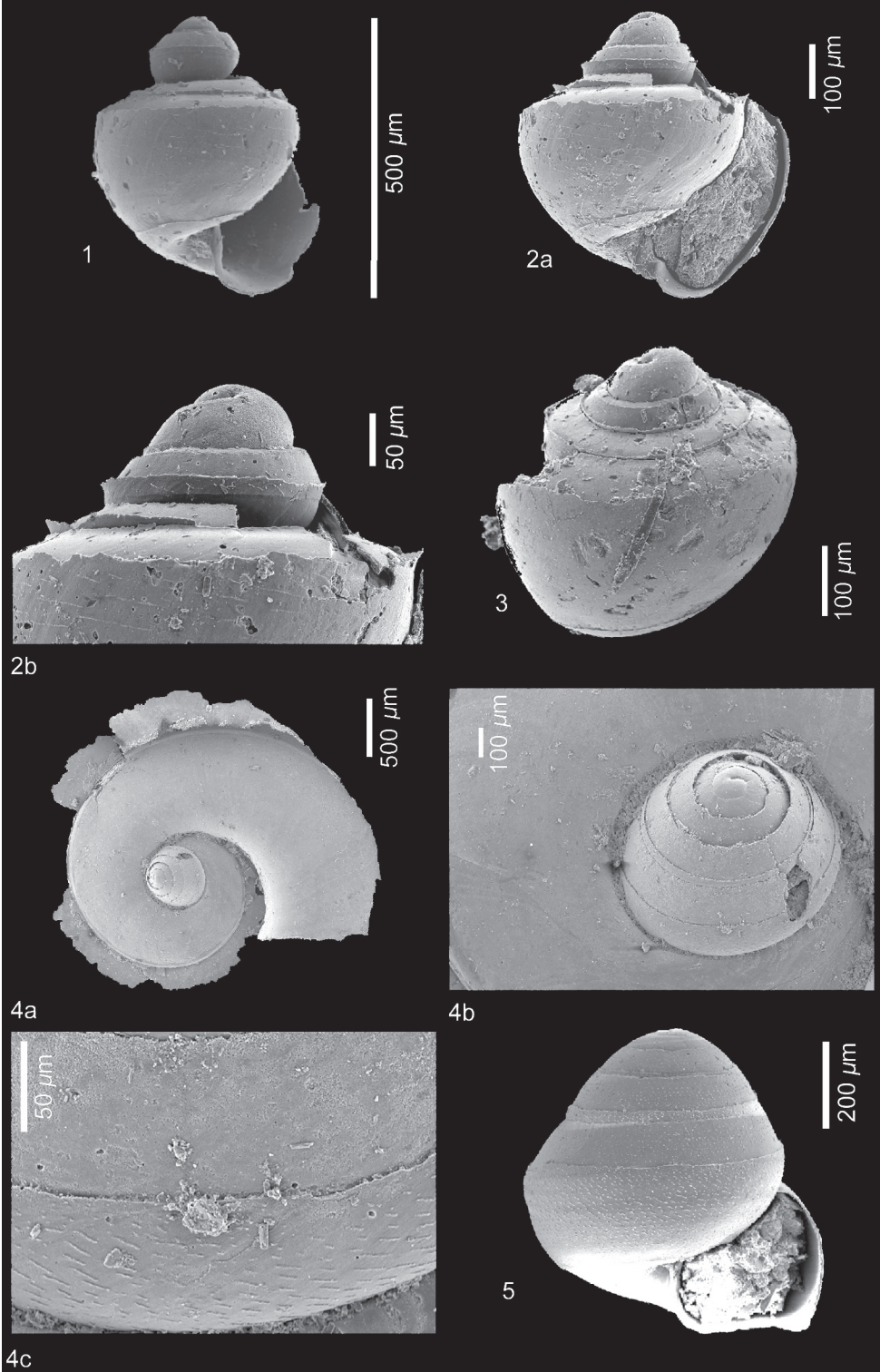

Plate 16

Atlanta tokiokai van der Spoel & Troost, 1972

Fig. 1. Anda3, RGM 539 849. a-c, micro-ornament of protoconch whorls.

Oxygyrus keraudreni (Lesueur, 1817)

Fig. 2. Anda1, RGM 539 782. a, apical view. b, early whorls, apical view.

Fig. 3. Anda1, RGM 539 783. a, juvenile specimen, apertural view. b, micro-ornament of early whorl.

Fig. 4. Anda1, RGM 539 784. Juvenile specimen, apertural view.

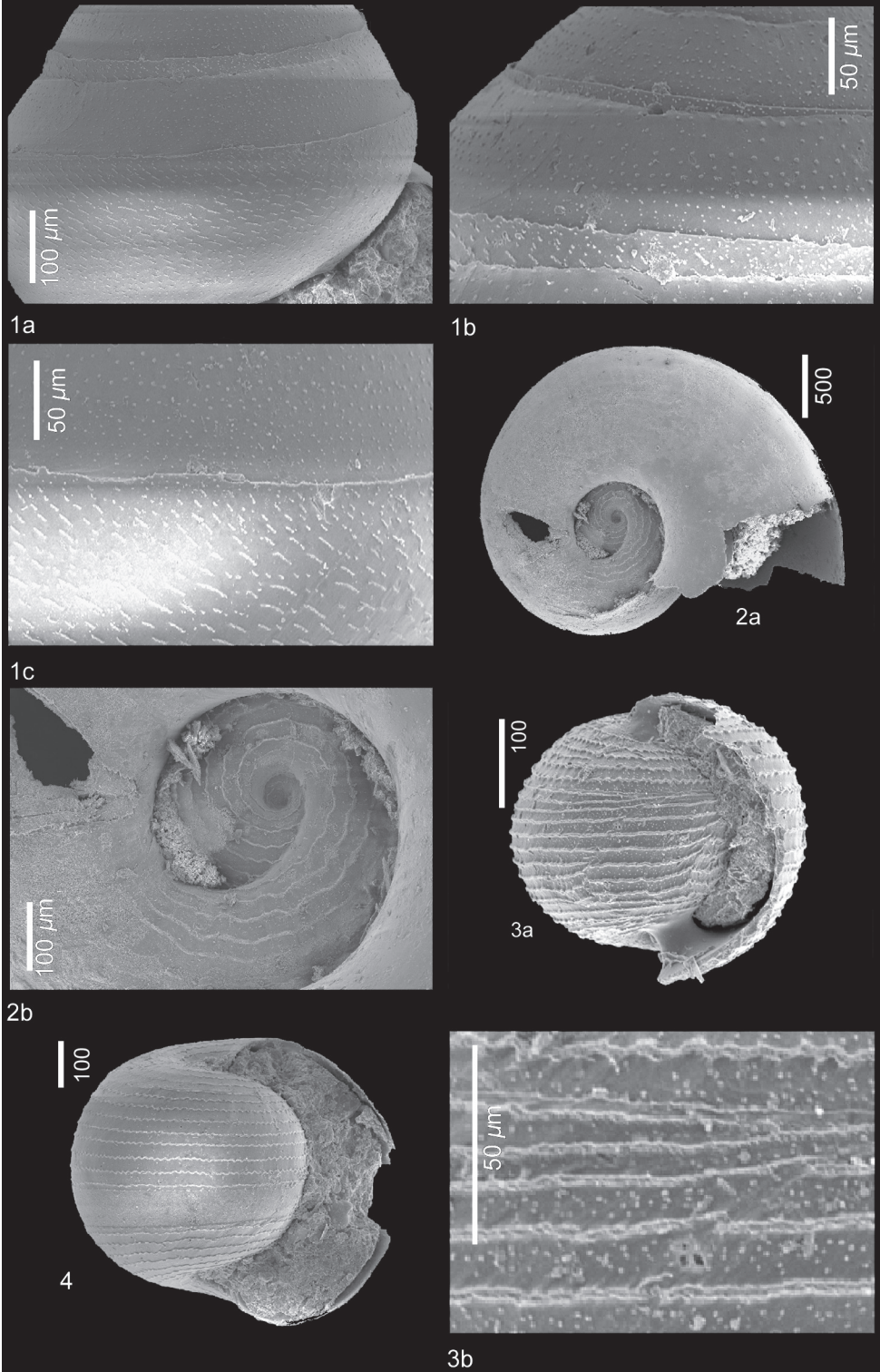

Plate 17

Protatlanta rotundata (Gabb, 1873)

Fig. 1. Anda3, RGM 539 785. a, apical view. b, protoconch, apical view. c, nucleus of protoconch and early whorls, apical view. d, protoconch, oblique apical view.

Fig. 2. Anda3, RGM 539 786. a, protoconch, apical view. b, detail of nucleus and early whorls.

Fig. 3. Anda3, RGM 539 787. Protoconch, apertural view.

Protatlanta souleyeti (Smith, 1888)

Fig. 4. Anda4, RGM 539 790. Protoconch, apertural view.

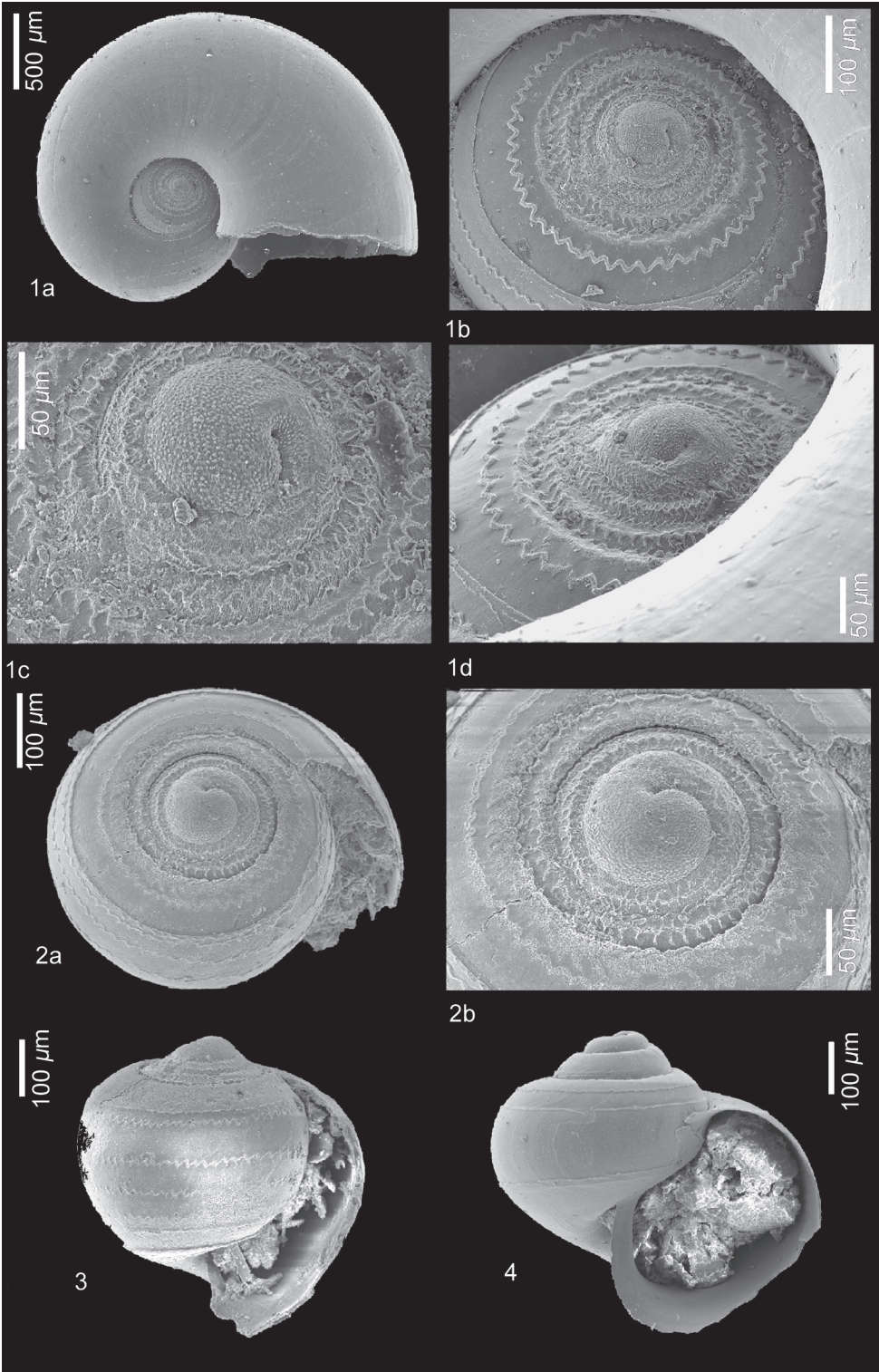

Plate 18

Protatlanta souleyeti (Smith, 1888)

Fig. 1. Anda4, RGM 539 788. a, apical view. b, protoconch, apical view. c, protoconch, oblique apical view.

Fig. 2. Anda3, RGM 539 789. Form without protoconch ornament. a, apical view. b, protoconch, apical view. c, protoconch, oblique apical view.

Pterosoma cf. planum Lesson, 1827

Fig. 3. Anda2, RGM 539 791. a, protoconch, apical view. b, detail of protoconch, apical view.

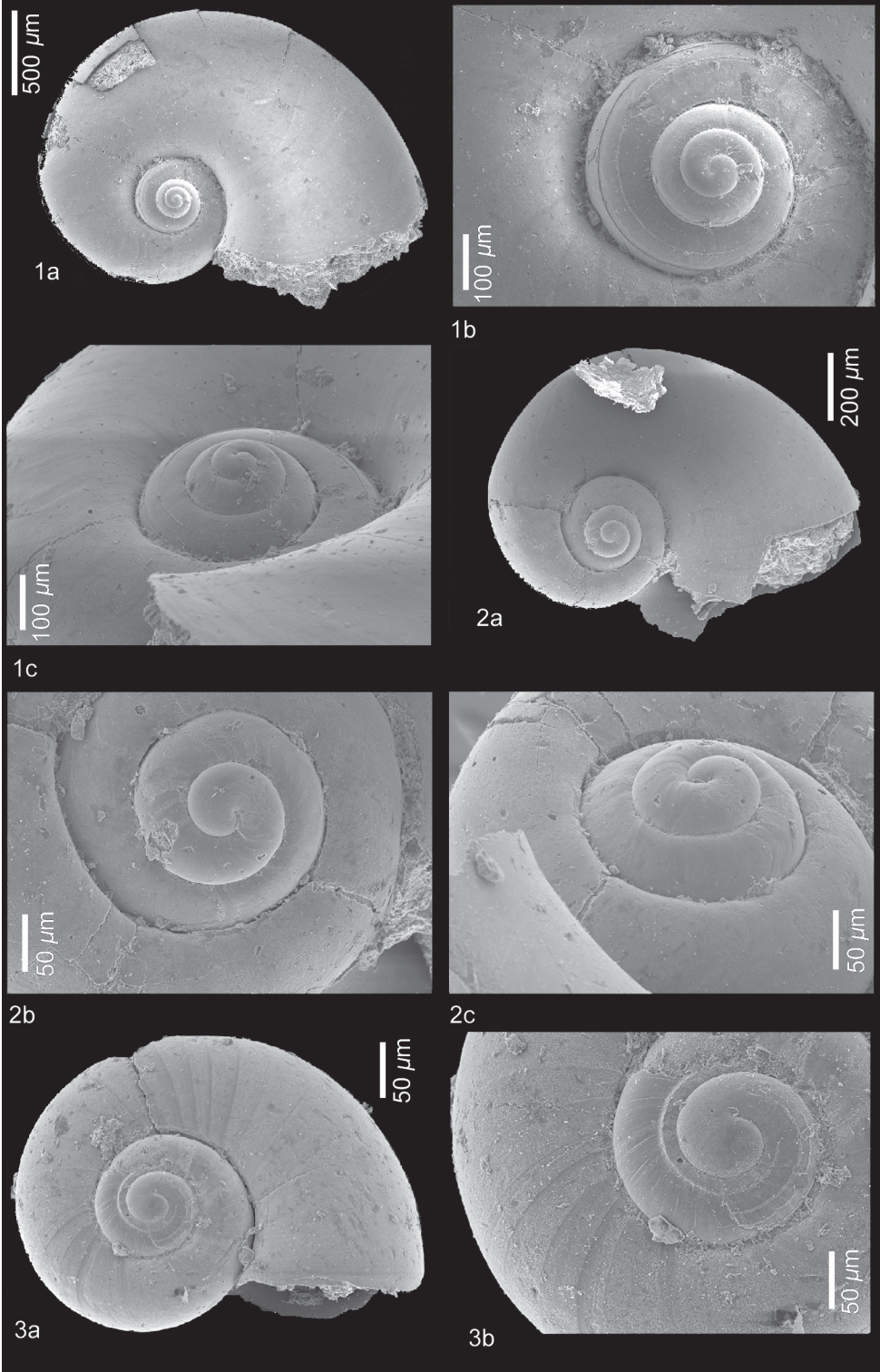

Plate 19

Pterosoma cf. planum Lesson, 1827

Fig. 1. Anda2, RGM 539 791. Detail of nucleus and first whorl.

Fig. 2. Anda2, RGM 539 792. Protoconch, apertural view.

Fig. 3. Anda2, RGM 539 793. a, protoconch, umbilical view. b, protoconch, oblique umbilical view.

Fig. 4. Anda4, RGM 539 797. a, protoconch, apical view. b, protoconch, detail of nucleus and early whorl.

Fig. 5. Anda4, RGM 539 798. a, protoconch, apical view. b, protoconch, detail of nucleus and early whorl.

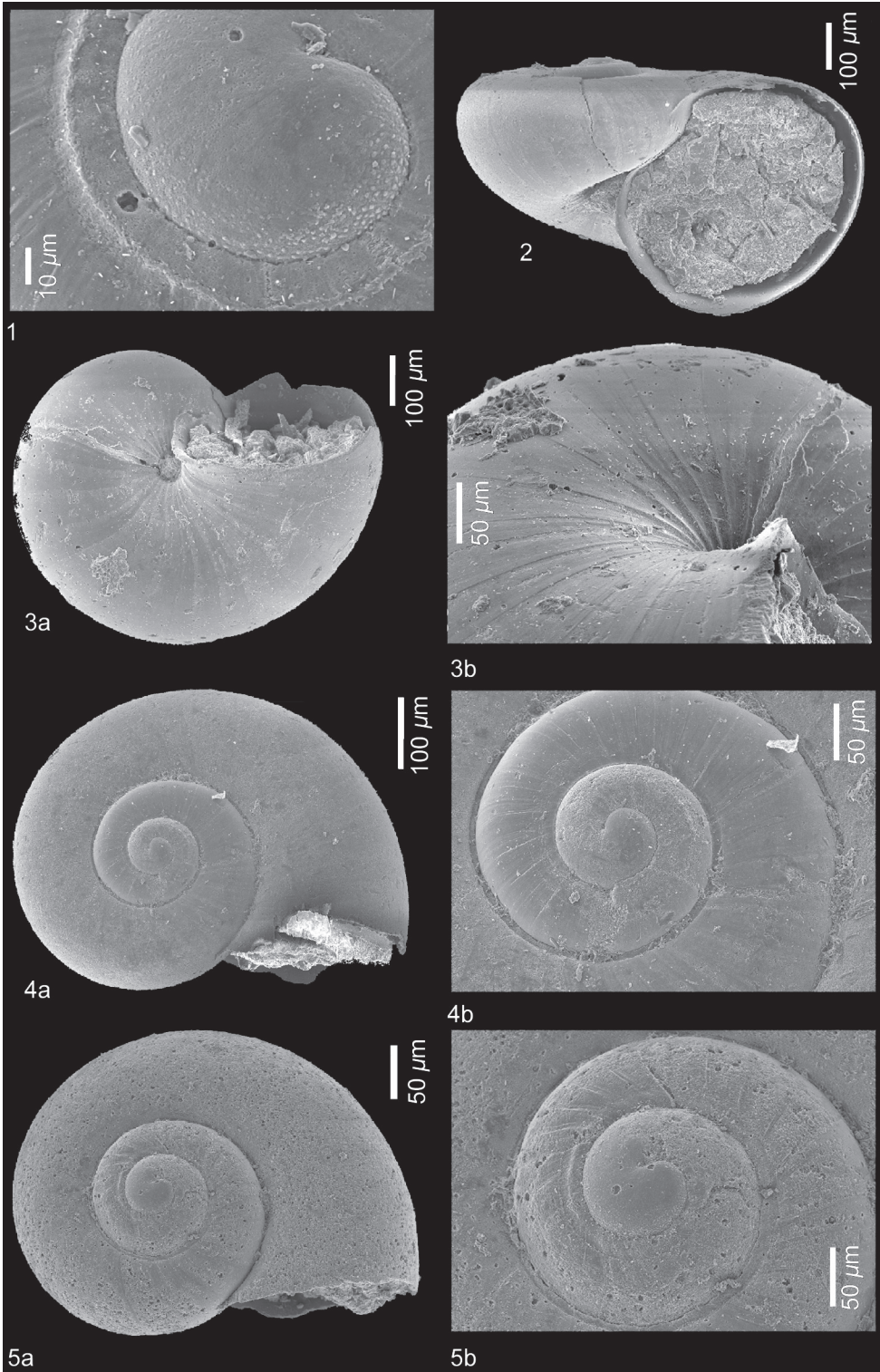

Plate 20

Pterosoma cf. planum Lesson, 1827

Fig. 1. Anda4, RGM 539 798. Protoconch, detail of nucleus and early whorl, apical view.

Fig. 2. Anda3, RGM 539 799. a, protoconch, apical view. b, detail of nucleus and early whorl, apical view.

Carinaria sp.

Fig. 3. Anda2, RGM 539 794. a, protoconch, apical view. b, detail of nucleus and early whorl, apical view. c, nucleus and first whorl, oblique apical view.

Fig. 4. Anda2, RGM 539 795. Protoconch, apertural view.

Fig. 5. Anda2, RGM 539 796. Protoconch, umbilical view.

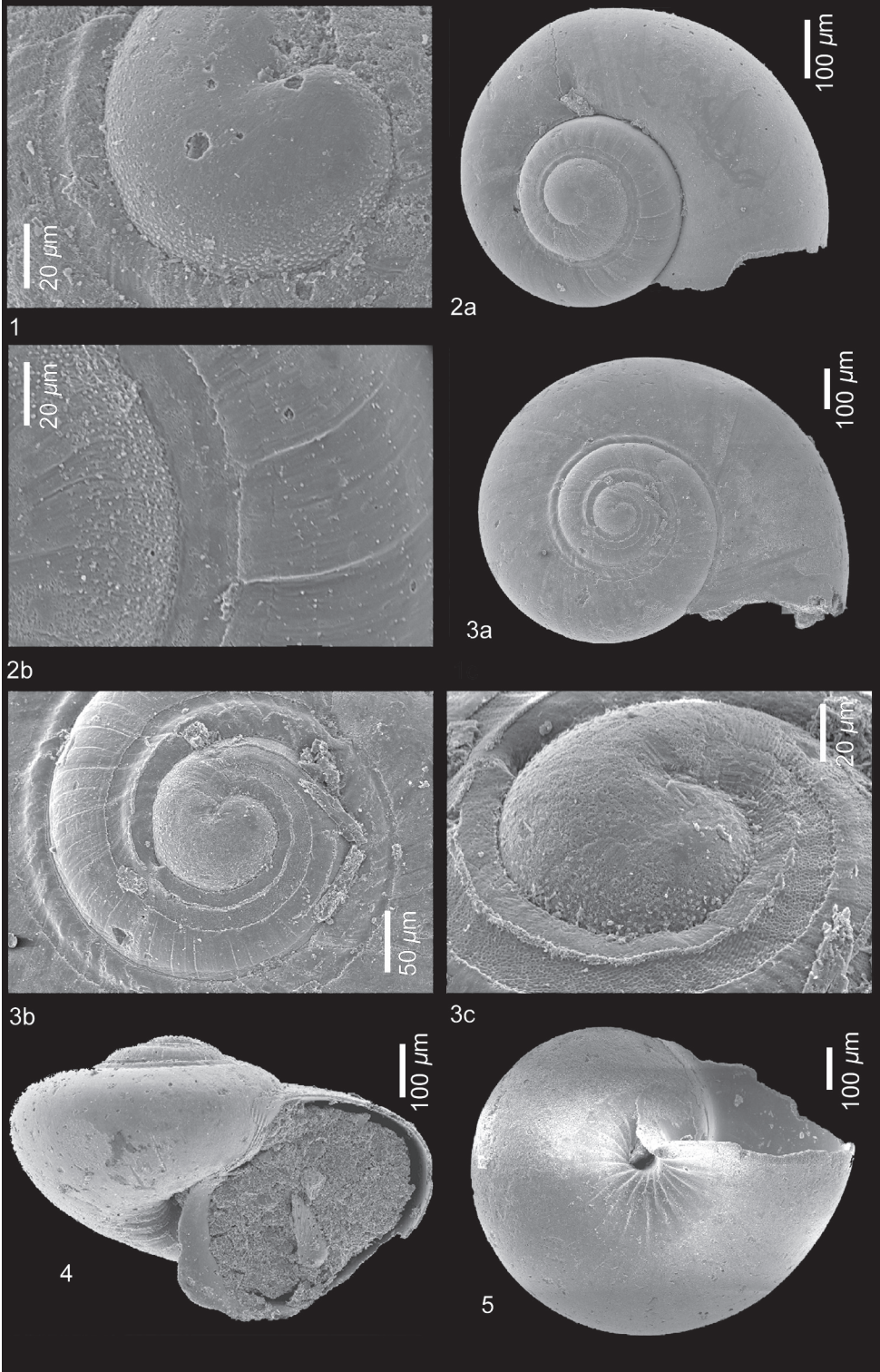

Plate 21

Heliconoides inflata (d'Orbigny, 1836)

Fig. 1. Anda2, RGM 539 800. Apical view.

Fig. 2. Anda1, RGM 539 801. a, left lateral view. b, detail of micro-ornament on apertural rostrum.

Fig. 3. Anda1, RGM 539 802. Juvenile specimen, apertural view (note thickened apertural margin at place of rostrum).

Heliconoides sondaari sp. nov.

Fig. 4. Paratype. Anda3, RGM 539 803. Left lateral view.

Fig. 5. Paratype. Anda3, RGM 539 804. Apertural view.

Fig. 6. Paratype. Anda3, RGM 539 805. Apical view.

Fig. 7. Paratype. Anda4, RGM 539 806. Apertural view.

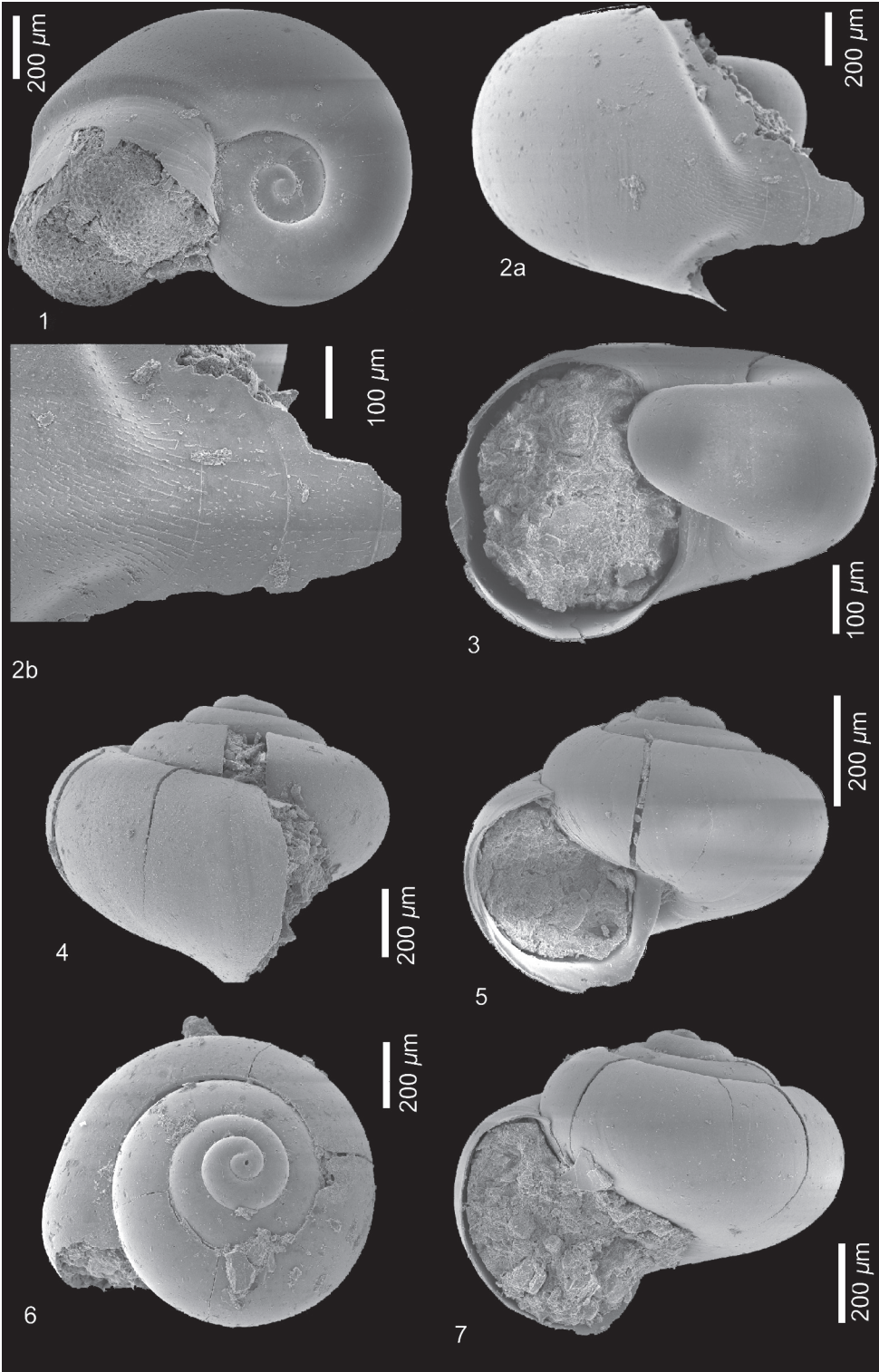

Plate 22

Heliconoides sondaari sp. nov.

Fig. 1. Paratype. Anda4, RGM 539 807. Left lateral view.

Limacina bulimoides (d'Orbigny, 1836)

Fig. 2. Anda4, RGM 539 808. a, apertural view. b, protoconch and early whorls, showing micro-ornament.

Fig. 3. Anda4, RGM 539 809. a, juvenile specimen, apertural view. b, micro-ornament on body whorl close to aperture.

Striolimacina andaensis sp. nov.

Fig. 4. Paratype. Anda4, RGM 539 812. a, apical view. b, micro-ornament close to apertural margin.

Striolimacina andaensis sp. nov.

Fig. 5. Paratype. Anda4, RGM 539 813. a, left lateral view. b, micro-ornament close to apertural margin.

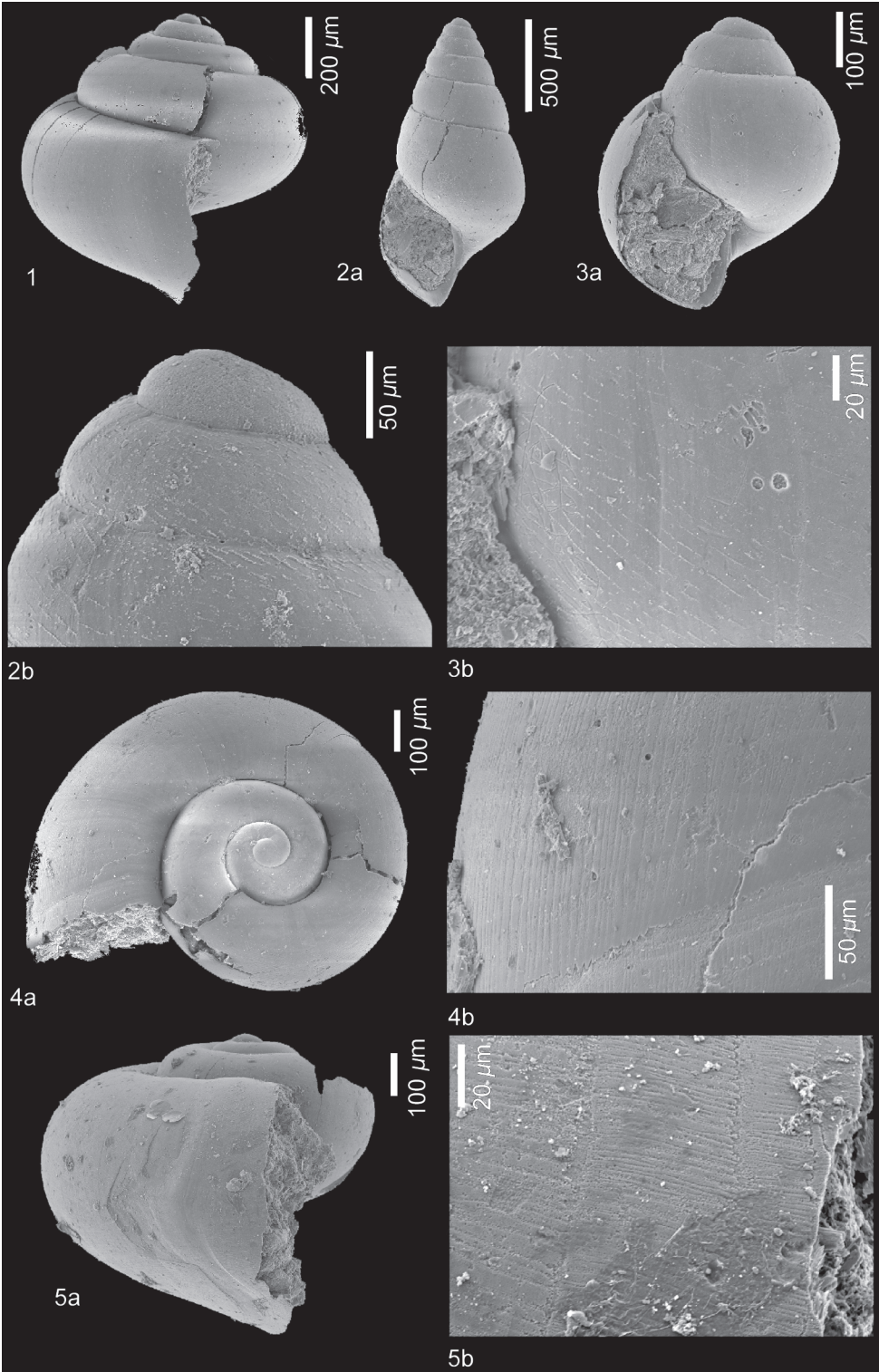

Plate 23

Architectonicidae sp.

Figs. 1, 2. Anda1, RGM 539 810-811. Protoconchs, apertural views.

Creseis chierchiae (Boas, 1886) forma *constricta* Chen & Bé, 1964

Fig. 3. Anda1, RGM 539 814. Juvenile specimen retaining protoconch, frontal view.

Fig. 4. Anda4, RGM 539 815. Adult specimen, protoconch broken.

Fig. 5. Anda2, RGM 539 816. Protoconch.

Fig. 6. Anda2, RGM 539 817. Protoconch.

Creseis clava (Rang, 1828)

Fig. 7. Anda3, RGM 539 818. a, adult specimen. b, protoconch.

Fig. 8. Anda3, RGM 539 819. Adult specimen.

Hyalocylis marginata sp. nov.

Fig. 9. Paratype. Tiep2, RGM 539 826. Adult specimen with reduced ornament on younger shell parts, left lateral view.

Hyalocylis ? *marginata* sp. nov.

Fig. 10. Anda4, RGM 539 821. Juvenile specimen (no paratype), oblique dorsal/right lateral view.

Fig. 11. Anda4, RGM 539 820. Juvenile specimen (no paratype), left lateral view.

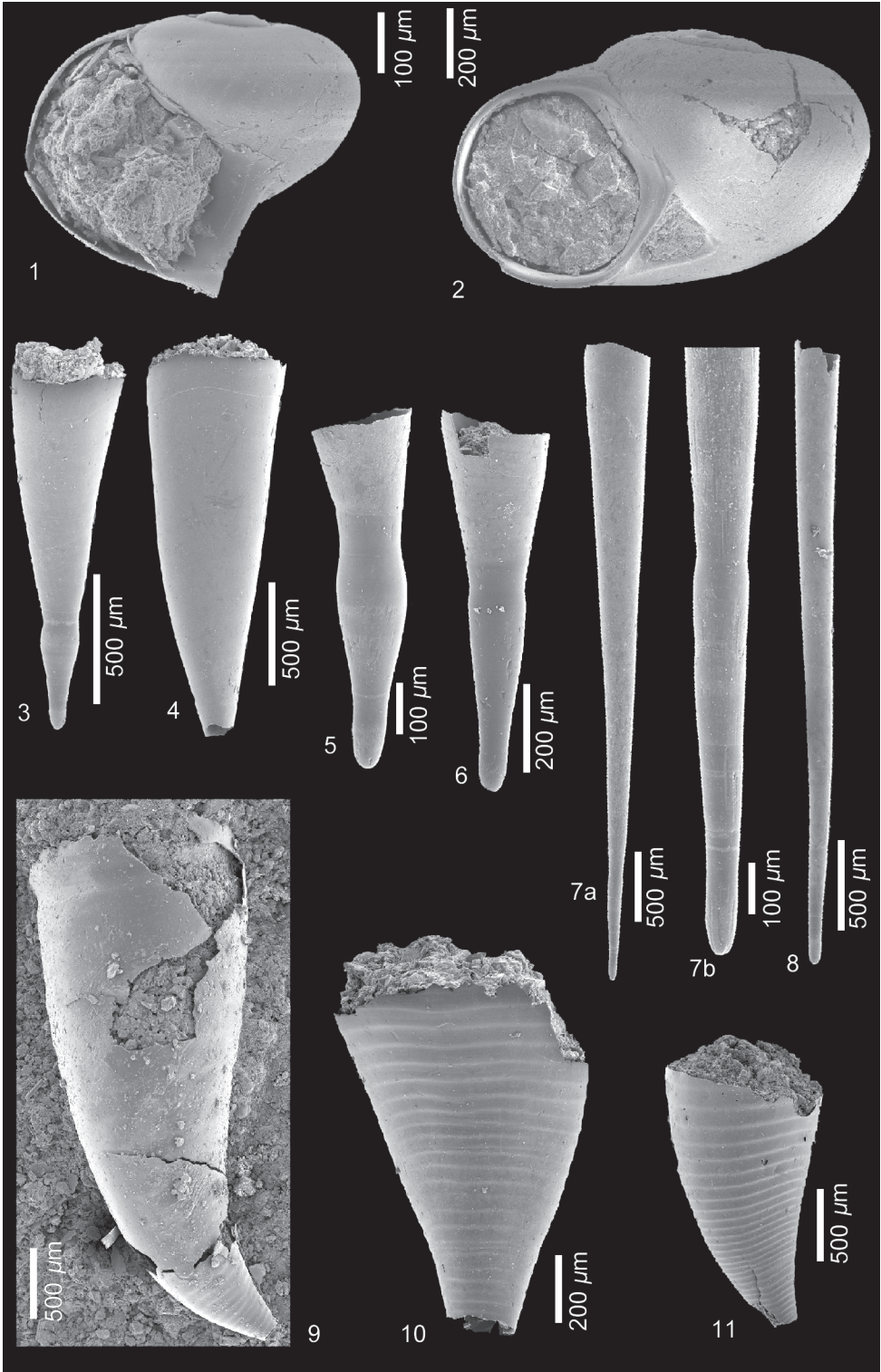

Plate 24

Cuvierina (Urceolarica) urceolaris (Mörch, 1850).

Fig. 1. Anda4, RGM 539 822. Protoconch.

Styliola subula (Quoy & Gaimard, 1827)

Fig. 2. Anda3, RGM 539 827. Specimen with additional furrow at apertural margin, dorsal view.

Fig. 3. Anda3, RGM 539 828. Dorsal view.

Clio (Bellardiclio) cuspidata (Bosc, 1802)

Fig. 4. Anda2, RGM 539 823. Protoconch and early teleoconch, dorsal view.

Fig. 5. Anda1, RGM 539 825. Protoconch and early teleoconch, right lateral view.

Clio (Clio) convexa convexa Boas, 1886

Fig. 6. Anda2, RGM 539 829. Protoconch and early teleoconch, lateral view.

Fig. 7. Anda2, RGM 539 830. Protoconch and early teleoconch, dorsal or ventral view.

Clio (Balantium) cf. hataii (Noda, 1972)?

Fig. 8. AndaDeVos, RGM 539 824. Protoconch and early teleoconch, right lateral view.

Clio (Clio) pyramidata Linné, 1767 forma *lanceolata* (Lesueur, 1813)

Fig. 9. Anda4, RGM 539 831. a, protoconch and early teleoconch, ventral view. b, protoconch, ventral view.

Fig. 10. Anda4, RGM 539 832. Juvenile specimen, left lateral view.

Diacria italica Grecchi, 1982 forma *fissicostata* f. nov.

Fig. 11. Paratype. Anda2, RGM 539 833. Protoconch and early teleoconch, dorsal view.

Fig. 12. Paratype. Anda2, RGM 539 834. Protoconch and early teleoconch, lateral view.

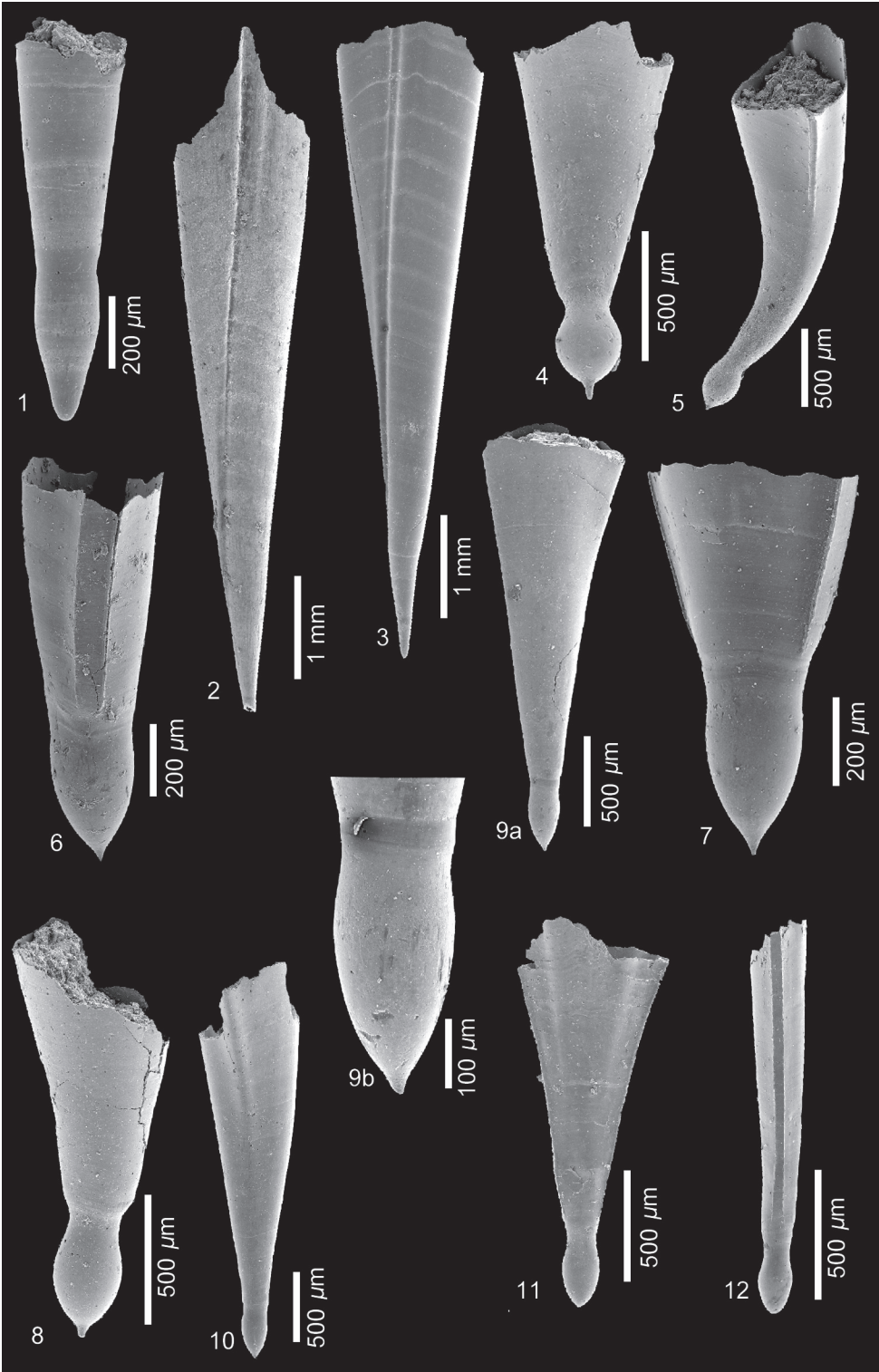

Plate 25

Diacria philippinensis sp. nov.

Fig. 1. Paratype. Anda1, RGM 539 835. a, dorsal view. b, detail of dorsal apertural lip.

Diacria trispinosa (de Blainville, 1821) forma *bisulcata* Gabb, 1873

Fig. 2. Anda2, RGM 539 836. a, protoconch, lateral view. b, protoconch-1 and early part of protoconch-2, lateral view.

Fig. 3. Anda2, RGM 539 837. Protoconch, dorsal or ventral view.

Diacria sp.

Figs. 4-6. AndaClif1, RGM 539 838-840. 4a, 5a, lateral view. 6a, ventral or dorsal view, 4b, 5b, 6b, protoconch-1 enlarged.

Sphaerocina convolvula sp. nov.

Fig. 7. Paratype. AndaDeVos, RGM 539 841. a, left lateral view. b, protoconch enlarged.

Cymbuliidae sp.

Fig. 8. Anda3, RGM 539 842. Protoconch, apical view.

Gymnosomata sp.

Fig. 9. Tiep2, RGM 539 843. a, protoconch, lateral view. b, protoconch-2 and early teleoconch, enlarged.



